



MARKAR AND PEMKO CATALOG

PEMKO
ASSA ABLOY

Experience a safer
and more open world

General Information	2	Acoustic Thresholds	104
About the Pemko Product Line	8	Threshold with Flexible Joint	104
The West Coast Stocking Program	9	Concealed Fastener Thresholds	105
General Information & Terms	10	Eco-V™ Thresholds	106
Materials & Finishes Information	12	Adjustable-Width Eco-V™ Threshold	107
Product Testing / Classification Symbols	13	Heavy Duty Latching Panic Exit Saddle Threshold	108
Barrier-Free Systems	15	Heavy Duty Thresholds	108
ANSI/BHMA Standards	16	Modular Heavy Duty Thresholds	109
Markar Continuous Pin and Barrel Hinges	17	Floor Plates/Safety Treads	110
General Information	18	Aluminum Plates	111
Hinge Finishes	20	Carpet Separators	112
Hinge Numbering System and Standard Lengths	21	Floor Plate Supports/Accessories and Elevators	113
Continuous Hinge Modifications	22	Threshold Stop Strips	114
3500 Series Stainless Steel Pin and Barrel Security Hinges	25	Floor Closer Thresholds/Cover Plate Assemblies	115
600 Series Stainless Steel Pin and Barrel Hinges	29	ANSI/BHMA A156.21 Thresholds - Cross Reference	116
300 Series Stainless Steel Pin and Barrel Hinges	30	Modular Ramps:	119
300 Series Stainless Steel Edge Guards	45	Ramp Ordering Information	120
200 Series Carbon Steel Pin and Barrel Hinges	48	Modular Ramp Threshold Assemblies - Flush Applications	121
100 Series Aluminum Pin and Barrel Continuous Hinges	50	Modular Ramp Threshold Assemblies - Offset (7" Top Plate)	122
900 Series Toilet Partition Hinges	52	Modular Ramp Threshold Assemblies - Offset (3½" Top Plate)	123
400 Series Toilet Partition Hinges	54	Modular Ramp Threshold Components	124
Pivots	56	Modular Ramp Threshold Assemblies - Variables	125
Flat Astragals	57	Risers for Modular Ramps	125
Fasteners and Fastener Packs	59	Miter Returns For All Modular Ramp Thresholds	126
Tools, Parts, and Accessories	63	Barrier-Free Ramp Thresholds	127
Custom Lengths	64	Fire Retardant and Styrene Butadiene Rubber Ramp Thresholds	128
PemkoHinge® Geared Continuous Hinges:	65	Recycled Rubber Ramp Assembly	129
What is PemkoHinge®?	66	Door Bottoms:	131
Ordering Chart	66	Automatic Door Bottoms	132
BHMA Certification Program	67	Residential Automatic Door Bottoms	136
Hospital Tip	67	End Plates for Automatic Door Bottoms	137
Cycle Requirements and Weight Bearing	67	Excessive Gap Door Bottom Solutions	138
UL Fire Labeling	67	Excessive Gap Door Top Solutions	138
Options for Electrically Modified Continuous Geared Hinges	68	Eco-V™ Door Shoes	138
X-Series PemkoHinge®	69	Door Shoes	139
Offset Hinges	70	Thermally Broken Door Shoe	141
Full Mortise Hinges	71	Door Sweeps for Hollow Metal Doors	142
Special Full Mortise Hinges	72	Fabrication Options for Door Shoes	142
Kawneer Full Mortise Hinges	73	Door Bottom Sweeps	143
Raised Gear Hinge	73	Stainless Steel Door Bottom Sweeps	146
Full Mortise Safety Hinges	74	Specialty Door Bottoms	147
Wide Throw Full Mortise Hinges	75	Door Top Weatherstrip	147
Wide Throw Half Surface Hinges	75	Heavy Duty Door Bumper	147
Half Surface Hinges	76	Astragals & Meeting Stiles	149
Half Mortise Hinges	76	Astragal and Meeting Stile Gasketing - Split Astragals	150
Full Surface Hinges	77	Split Astragals with Snap Covers – Concealed Fasteners	152
Full Surface Center Pivot Hinges	77	Meeting Stile Gasketing	152
Full Surface Balanced Pivot Hinge	77	Adhesive Astragal/Meeting Stile Seals	154
Full Mortise Residential Hinges	78	Adjustable Astragals	154
Firepins™	79	"T" and Overlapping Astragals	155
Double Swing Hinge	80	Adhesive-Backed Mullion Gasketing	156
Emergency Release Stop	80	Adhesive-Backed Astragal Seal	156
1000 Series Aluminum Double Swing Hinge	81	Offset Security Bar	156
Power Transfer Units	82	Locking Astragals	157
Commercial Thresholds:	83	Outswing Locking Astragals	159
Saddle Thresholds	84	Brush Gasketing:	161
Half Saddle Thresholds	89	180° Aluminum Retainers	162
Offset Saddles and Offset Half Saddles	91	180° Concealed Fastener Retainers	163
Stainless Steel Saddles	92	90° Aluminum Retainers	164
Stainless Steel Half Saddles and Offset Saddles	92	45° Concealed Fastener Retainers	164
Thermal Break Saddles	93	Mortise Retainers	166
Stainless Steel Thermal Break Threshold	96	Aluminum Retainer with Rain Drip	166
Latching Panic Exit Saddles	97	Oak Retainers	166
Latching Panic Exit Saddles - Thermal Break	101	Meeting Stiles	167



Experience a safer
and more open world

800-824-3018 | www.pemko.com
Check the web site for the up-to-date catalog

Copyright © 2015-2024, ASSA ABLOY Accessories and Door Controls Group, Inc., an ASSA ABLOY Group company. All rights reserved.
Reproduction in whole or in part without the express written permission of ASSA ABLOY Accessories and Door Controls Group, Inc. is prohibited.

Perimeter Gasketing:	169		
Standard Perimeter Gasketing	170	TBS250A-SW Series	225
Perimeter Gasket Solutions for Sliding Doors	173	H600S-OH Series	226
Stainless Steel Perimeter Gasketing	174	H600S-SW Series	227
Adjustable Jamb Gasketing	175	H800S-OH Series	228
Heavy Duty Interlock Perimeter Gasketing	175	H800S-SW Series	229
Heavy Duty Perimeter Gasketing - Head Section	176	H1100A-OH Series	230
Heavy Duty Perimeter Gasketing - Standard Jamb	177	H1100A-SW Series	231
Perimeter Gasket Jamb Brackets	177	Husky Sliding Glass Series	232
Snap Cover Perimeter Gasketing With Concealed Fasteners	178	Pocket Frame Kit	233
Kerf-In Weatherstrip	179	Folding 100 Series	234
Magnetic Weatherstrip	180	Pacer Interior End Fold Series	235
Adhesive Perimeter Gasketing	180	Flexirol Interior End Fold Series	236
MicroShield® Antimicrobial Adhesive Gasketing	181	Stainless Steel Sliding Track Hardware System for Wood Doors	237
Excessive Gap Perimeter Solution	182	Stainless Steel Sliding Track Hardware System for Glass Doors	246
Interlock Weatherstrip For Wood Windows	182	Builders Series Flat Track for Wood Doors	248
Interlock Weatherstrip For Wood Doors	183	Designer Series Flat Track for Wood Doors	250
Cushion/Spring Weatherstrip	183	SIM 150 - 2 Door	252
Fasteners for Cushion, Spring and Interlock Weatherstrip	183	SIM 150 - 3 Door	253
Privacy Seals for Sliding Doors	184	Cascading Door with Sample Configurations	254
Adhesive Gasketing:	185	SDL Privacy Barn Door Lock	255
SiliconSeal Adhesive-Backed Fire/Smoke Gasketing	186	Options and Accessories	256
PemkoPrene® Adhesive-Backed Fire/Smoke Gasketing	187	Privacy Seal Sets	256
SiliconSeal Adhesive-Backed Meeting Stile Gasketing	187	Soft Close Systems	257
MicroShield® Antimicrobial Gasketing	188	Residential Thresholds	261
Hot Smoke Seal/SiliconSeal Combination Fire/Smoke Sealing	188	Interlocking Thresholds and Caps	262
Hospitality Products:	189	Interlocking Thresholds - Water Return	263
Privacy Door Latch, Bracket and Decals	190	Interlocking Hooks	263
SiliconSeal Adhesive Gasketing	191	Adjustable Eco-V™ Top Thresholds	264
Automatic Door Bottoms: Acoustic	192	Eco-V™ Top Thresholds	264
Door Shoes	192	Residential Saddles	264
Acoustic Adhesive Corner Pads	192	Bumper Thresholds for Outswing Doors	265
Automatic Door Bottoms	193	Squareback Thresholds	265
Eco-V™ Thresholds	194	Oak Thresholds	266
Adjustable-Width Eco-V™ Threshold	195	Sill Nosings	266
Stainless Steel Sliding Track Hardware System	196	Adjustable Aluminum Top Sills	267
Cascading Door with Sample Configurations	197	Adjustable Oak Top Sills	268
SHS80 System	198	Outswing Adjustable Oak Top Sills	269
Bypass Track Series	199	Residential All-Aluminum Adjustable Sills	269
Acoustic Products:	201	Fixed Eco-V™ Top Residential Sills	270
Basic Acoustic Information	202	Residential All-Aluminum Fixed Sills	270
Acoustic Seal Sets	204	Outswing Fixed Bumper Sills	271
Acoustic Thresholds	205	Extenders For All Residential Sills	271
Saddle Thresholds	206	Floor Molding, Trim, & Handyshapes™	273
Automatic Door Bottoms - Acoustic	207	Carpet Bar and Seam Binding	274
Door Shoes	207	Stair Nosing	274
Acoustic Adhesive Corner Pads	207	Oak Seam Binding, Floor Edging, and Carpet Trim	274
Standard Perimeter Gasketing	208	Weatherization Products	275
SiliconSeal Adhesive-Backed Gasketing	208	Foam Tape	276
Pemko Sliding & Folding Hardware:	209	Neoprene Tape	276
H180A Series	210	Miscellaneous Tape	277
SHS80 Series	211	Spring Bronze Weatherstrip	277
Sliding 200 Series	212	Garage Door Weatherstrip	277
Side Wall Track (SWT) System	213	Fire Glazing Tape	279
Bypass Track Series	216	Fire Glazing Tape	280
SIM200A Series	217	Fire Glazing Tape Applications	281
LP200 Series	218	Door & Frame Accessories	287
Sirocco Series	219	Glazing Bead/Spreader Bar	288
H300S-OH Series	220	Reinforcements - Fillers	288
H300S-SW Series	221	Reinforcements - Misc.	289
H440A-OH Series	222		
H440A-SW Series	223		
TBS250A-OH Series	224		

800-824-3018 | www.pemko.com

Check the web site for the up-to-date catalog

Copyright © 2015-2024, ASSA ABLOY Accessories and Door Controls Group, Inc., an ASSA ABLOY Group company. All rights reserved.
Reproduction in whole or in part without the express written permission of ASSA ABLOY Accessories and Door Controls Group, Inc. is prohibited.

PEMCO
ASSA ABLOY

Experience a safer
and more open world

Product	Index	Product	Index	Product	Index	Product	Index	Product	Index
1A/290.....	221	70D-100.....	183	151.....	84	217.....	139	256.....	90
1A/290/EC.....	220	70E-99.....	183	151.....	206	218.....	264	256x6.....	88
1A/301.....	227	72.....	240	154.....	86	218OAK.....	266	256x6_FG.....	93
1A/301/EC.....	226	73.....	183	154.....	206	219.....	264	257.....	127
1A/550.....	231	74.....	183	154SS.....	92	219OAK.....	266	257x259.....	115
1AX/290.....	221	75.....	183	157.....	91	221.....	141	257x259.....	127
1AX/301.....	227	82.....	241	158.....	91	222.....	142	259.....	127
1AX/301.....	229	89/2N.....	220	158SS.....	92	223.....	140	270.....	84
1B.....	223	92.....	242	159.....	99	227.....	110	271.....	84
1BX.....	223	94A.....	210	166.....	86	228.....	110	272.....	84
2.....	13	94A.....	220	169.....	86	229.....	110	273.....	89
2P.....	182	94A.....	234	170.....	86	230.....	112	273x3_FG.....	93
3A/290.....	220	94A.....	256	171.....	87	234.....	139	273x4_FG.....	93
3A/301.....	226	101.....	262	172.....	87	236.....	112	273x224_FG.....	102
3A/301.....	228	102N.....	210	173.....	84	249.....	264	273x292_FGPK.....	103
3AX/290.....	220	102N.....	220	174.....	112	250.....	264	274.....	89
3AX/301.....	226	102N.....	237	175.....	86	252.....	90	274x4.....	85
3AX/301.....	228	102N.....	248	175.....	206	252SS.....	92	274x4_FG.....	93
4C.....	182	102N.....	256	175SS.....	92	252x2_FG.....	94	274x4x270.....	115
4P.....	182	102WA.....	210	176.....	87	252x2SSFG.....	96	274x4x271.....	115
8-12/SN.....	232	102WA.....	212	176.....	115	252x3_FG.....	94	274x224_FG.....	102
10.....	10	102WA.....	217	176x170.....	115	252x3SSFG.....	96	274x292_FGPK.....	103
10.....	182	102WA.....	221	176x171.....	115	252x4SSFG.....	96	276.....	85
12.....	246	102WA.....	223	177.....	99	252x226.....	100	276.....	115
14/1.....	111	102WA.....	229	179.....	98	252x226_FG.....	101	276x270.....	115
18/1.....	111	102WA.....	256	181.....	99	253.....	90	276x271.....	115
21/550/P.....	236	102WN.....	210	182.....	91	253SS.....	92	277.....	98
21BO/4.....	235	102WN.....	217	183.....	113	253x3_FG.....	94	278.....	89
21B/P.....	235	102WN.....	221	184.....	114	253x3SS FG.....	96	278x224_FG.....	102
21N/94.....	235	102WN.....	223	185.....	100	253x4_FG.....	94	278X292_FGPK.....	103
21R/94.....	236	102WN.....	227	190.....	110	253x4SS FG.....	96	279.....	89
30.....	8	102WN.....	229	191.....	110	253x6_FG.....	95	279x224_FG.....	102
30.....	183	102WN.....	248	192.....	110	253x226_FG.....	101	279x292_FGPK.....	103
32.....	247	106HF/94.....	234	193.....	110	254.....	90	280.....	210
41M.....	183	106N/94.....	256	193x2/195.....	115	254SS.....	92	280.....	217
43.....	183	106R/94.....	210	195.....	113	254x4.....	88	280.....	234
52.....	11	106R/94.....	220	196.....	113	254x4_FG.....	95	280_SWF.....	213
56.....	144	106R/94.....	256	196.....	147	254x4SS FG.....	96	280_SWT.....	213
57.....	144	108.....	262	200.....	113	254x4x170.....	115	280_SWTKIT.....	213
57A/N.....	228	110.....	262	206.....	264	254x4x171.....	115	281.....	211
57A/S.....	226	111.....	243	208.....	264	254x5_FG.....	95	281.....	217
57B.....	222	114.....	262	209.....	139	254x226.....	100	281.....	232
57K/N.....	220	120.....	262	210.....	139	254x226_FG.....	101	281.....	234
61.....	263	136.....	263	211.....	139	255.....	90	281.....	256
62.....	237	142.....	263	212.....	264	255x5.....	88	282.....	113
66.....	263	145.....	263	215.....	139	255x5_FG.....	94	282HD.....	234
68.....	147	146.....	263	216.....	139	255x 226.....	100	283.....	113
70C-100.....	183	149.....	265	216_FG.....	141	255x226_FG.....	101	283.....	234



Experience a safer
and more open world

800-824-3018 | www.pemko.com
Check the web site for the up-to-date catalog

Copyright © 2015-2024, ASSA ABLOY Accessories and Door Controls Group, Inc., an ASSA ABLOY Group company. All rights reserved.
Reproduction in whole or in part without the express written permission of ASSA ABLOY Accessories and Door Controls Group, Inc. is prohibited.

Product	Index	Product	Index	Product	Index	Product	Index	Product	Index
284D	232	324	266	601H	211	2051	265	2755	89
285	172	325XGSS	138	601H	217	2052	265	2802	197
287R1-KIT	210	326	266	601H	232	2053	265	2802	216
287R1-KIT	212	327	266	601H	254	2054	265	2802	254
287R1-KIT	216	330	172	601H	256	2113	140	2802BT	216
289B	234	331	183	601P	222	2113	192	2802BT	256
289T	234	332	171	650	105	2120	274	2803	252
290	114	335	175	651	105	2132	274	2812	197
290	177	336	175	671	105	2132W	274	2812	216
290	220	344	147	766	91	2134	274	2812	254
294	173	345	144	766x3_FG	95	2170	138	2812	256
296	172	345	145	950	173	2173	140	2815_M	180
297	150	345	166	950	184	2173	192	2891	176
297	170	346	147	971A	210	2211	141	2892	176
300	153	347	147	971A	217	2212	141	2893	176
301	226	350	175	971A	220	2212	207	2902	177
303	150	351	154	971A	222	2219	274	2903	177
303	170	354	154	971A	226	2219W	274	3151	143
303	208	355	155	971A	228	2221	142	3151	172
305	150	356	155	971A	230	2266	110	3151SS	146
305	171	357	155	971A	234	2286	110	3261	266
305SS	150	359	155	971A	256	2343	140	3443	159
305SS	174	368	143	987	11	2343	192	3444	159
306	173	369	153	1075C	210	2364	112	3452	144
307	144	371	153	1076	197	2500W	266	3452	145
308	144	372	153	1076	254	2500W	274	3452	166
309	173	375	155	1547	86	2548	87	3493	156
310	151	375	171	1547	206	2548	115	3494	156
311CIN	151	379	175	1710	87	2548x170	115	3495	158
312	172	394	173	1715	108	2548x171	115	3496	158
312	208	394	184	1716	109	2549	88	3572	156
313	147	403/2	235	1717	109	2550	88	3692	140
313	152	405	136	1718	109	2555	90	3692	192
314	147	411	135	1719	109	2565	90	3692	207
314	152	411	193	1842	114	2705	108	4131	134
315	143	412	134	1855	99	2715	108	4131	193
315	172	420	135	1951	112	2716	108	4301	134
315	208	434	135	2001	97	2727	91	5025	166
315SS	146	550A	230	2002	97	2746	89	5041	166
315SS	174	550A	236	2005	97	2746x6	85	5061	166
316	151	556/21	236	2006	97	2746x6_FG	93	5100	166
316	170	556/57	230	2006STC	104	2746x292_FGPK	103	5110	156
317	147	566	91	2006STC_	205	2748	85	8451	271
319	171	566x3_FG	95	2008	104	2748	115	8452	271
319SS	174	573x5_FG	104	2008	205	2748x270	115	18041	151
321	143	600A	222	2009	98	2748x271	115	18041	163
321SS	146	600A	235	2009	205	2749	85	18041	167
322	175	601H	197	2010	98	2750	85	18050	163

800-824-3018 | www.pemko.com

Check the web site for the up-to-date catalog

Copyright © 2015-2024, ASSA ABLOY Accessories and Door Controls Group, Inc., an ASSA ABLOY Group company. All rights reserved.
 Reproduction in whole or in part without the express written permission of ASSA ABLOY Accessories and Door Controls Group, Inc. is prohibited.



Experience a safer
and more open world

Product	Index	Product	Index	Product	Index	Product	Index	Product	Index
18061.....	145	90137.....	164	EV2322.....	194	FS302.....	34	HM.....	76
18061.....	151	94518.....	267	EV2325.....	106	FS402.....	55	HM304.....	36
18061.....	163	94518_W.....	268	EV2325.....	194	FS902.....	53	HS.....	76
18061.....	167	95518.....	267	EV2326.....	106	FS910.....	53	HS203.....	49
18062.....	163	95518_W.....	268	EV2326.....	194	FS3501.....	26	HS303.....	35
18062W.....	166	293100.....	145	EXT2.....	271	FS3502.....	27	HSS20XGxS773.....	182
18100.....	145	293100.....	163	EXT3.....	271	FS_CP.....	77	HSS1000.....	188
18100.....	163	ACP112.....	192	EXT3/4.....	271	FS/SC309.....	38	HSS2000.....	188
18100W.....	166	ACP112.....	207	EZGAP™ XG10.....	182	G60 to G70.....	246	HSS2000.....	285
18137.....	145	ADJ232V8.....	107	F134.....	210	GLASSGUIDE.....	246	HSS2000xS44.....	188
18137.....	162	ADJ232V8.....	195	F134.....	216	GS2-20PK.....	288	HSS2000xS88.....	187
18175.....	162	ADJ232V14.....	107	F134.....	252	GS3-20PK.....	288	HSS7750.....	188
18250.....	162	ADJ232V14.....	195	F134.....	256	GS4-20PK.....	288	HS_SF.....	76
18400.....	162	ADJ232x2325V8.....	107	F160C.....	222	H180A.....	210	K28_-SWEP.....	213
19125.....	111	ADJ232x2325V8.....	195	F160ECP.....	222	H200.....	212	K134EP.....	211
29310.....	152	AM88.....	181	F200C.....	223	H200PACK.....	212	K134EP.....	217
29310.....	178	AM88.....	188	F200ECP.....	223	H200PACK.....	256	K134EP.....	256
29313.....	178	B1923.....	56	FA68.....	57	H222R1.....	197	K411.....	137
29324.....	152	BAR.....	237	FA70.....	57	H222R1.....	210	K412.....	137
29324.....	163	BKT050.....	177	FA80.....	57	H222R1.....	233	K420.....	137
29324.....	167	BKT075.....	177	FG3000S45.....	280	H222R1.....	254	K435.....	137
29326.....	152	BKT1532.....	177	FG3000S45.....	281	H300S-OH.....	220	K435-PREM.....	137
29326.....	163	BRACKET2.....	237	FG3000S45.....	282	H300S-SW.....	221	K436.....	137
29326.....	167	CB1-50PK.....	288	FG3000S45.....	283	H440A-OH.....	222	K436SM.....	137
29326.....	178	CR2-5PK.....	289	FG3000S45.....	286	H440A-SW.....	223	K1077_-SWEP.....	210
29344.....	164	DSH.....	80	FG3000S90.....	280	H600S-OH.....	226	K4133.....	137
29344.....	178	DSH1000.....	81	FG3000S90.....	284	H600S-SW.....	227	K4301.....	137
29346.....	164	E199.....	147	FG3000S90.....	285	H800S-OH.....	228	K_FM.....	73
29346.....	178	EG308.....	45	FIF2/275A.....	236	H800S-SW.....	229	LH100.....	218
29394.....	173	EGA305xG.....	138	FM.....	71	H1100A-OH.....	230	LP200A.....	218
29394.....	184	EGC308.....	46	FM100.....	50	H1100A-SW.....	231	MAG349.....	180
45041.....	165	EGT308.....	47	FM200.....	48	HBP200A.....	199	N84518.....	270
45061.....	165	EL-CEPT.....	82	FM300.....	30	HBP200A.....	216	N85518.....	270
45062.....	165	EL-EPT.....	82	FM300WT.....	31	HF2/100.....	234	NL1678.....	183
45100.....	165	EL-EPTL.....	82	FM300WT.....	32	HF2/100PACK.....	234	NL1734CPXE.....	183
45137.....	165	EL-EPT-SC.....	82	FM400.....	54	HF2/100PACK.....	256	NL13516.....	183
45175.....	165	EPD3.....	210	FM600.....	29	HF3-25PK.....	288	OS95518.....	269
45250.....	165	EPD3.....	216	FM900.....	52	HF4/100.....	234	OS_FM.....	70
45400.....	165	EPD3.....	237	FM3500.....	25	HG305.....	37	OS_HS.....	70
74518.....	269	EPD3.....	248	FM_RG.....	73	HG310.....	39	P50.....	180
75518.....	269	EPD3.....	252	FM_SF.....	74	HG311.....	40	P51B17.....	183
84514.....	270	ERS.....	80	FM_SLF.....	71	HG315.....	41	P51B17.....	277
85514.....	270	EV80.....	138	FM_SLF138.....	74	HG323.....	42	P240.....	276
90041.....	164	EV232.....	106	FM_SLI.....	71	HG326.....	43	P241.....	276
90062.....	145	EV232.....	194	FM_SLISF.....	74	HG329.....	44	P241-30.....	276
90062.....	164	EV2320.....	106	FS.....	77	HG3505.....	28	P242.....	276
90100.....	145	EV2320.....	194	FS102.....	51	HH3/290.....	220	P243.....	276
90100.....	164	EV2322.....	106	FS301.....	33	HH3/301.....	226	P244.....	276



Experience a safer
and more open world

800-824-3018 | www.pemko.com
Check the web site for the up-to-date catalog

Copyright © 2015-2024, ASSA ABLOY Accessories and Door Controls Group, Inc., an ASSA ABLOY Group company. All rights reserved.
Reproduction in whole or in part without the express written permission of ASSA ABLOY Accessories and Door Controls Group, Inc. is prohibited.

Product	Index	Product	Index	Product	Index	Product	Index	Product	Index
P260	276	PFBS	233	R2F	121	S88	180	SPFM_SLI	72
P261	276	PFBS	256	R2FMR	121	S88	186	STC411	133
P262	276	PFCDKIT	233	R2OS	122	S88	191	STC411	192
P263	276	PFFC-8	233	R2OSMR	122	S104	179	STC411	207
P264	276	PFHB-1	233	R2OSS	123	S105	179	STC4131	133
P265	276	PFHB-2	233	R2OSSMR	123	S109	179	STC4131	192
P266	276	PFHS	233	R.5F	121	S442	181	STC4131	207
P361V16	277	PFKIT-4	233	R.5FMR	121	S442	186	STOP1	240
P364R16	277	PFKIT-8	233	R.5OS	122	S442	191	STOP1	247
P365V16	277	PIF2/165A	235	R.5OSMR	122	S442	208	STOP1	256
P380	277	PIF4/165A	235	R.5OSS	123	S771	154	STOP2	237
P381	277	PK33	181	R.5OSSMR	123	S771	187	STOP2	239
P382	277	PK33	187	R.75F	121	S771	191	STOP2	245
P384	277	PK52	180	R.75FMR	121	S771x6	154	TBS250A-OH	224
P385	276	PK55	181	R.75OS	122	S771x6	181	TBS250A-SW	225
P386	276	PK55	187	R.75OSMR	122	S771x6	187	W60	196
P387	277	PY900	173	R.75OSS	123	S771x6	191	W60 to W100	237
P388	277	Q102	179	R.75OSSMR	123	S772	154	WING 10_H	126
P390	276	Q103	179	RAMP 1	124	S772	187	WING 16_H	126
P391	276	Q106	179	RAMP 2	125	S772	191	WING EXT_H	126
P392	276	Q107	179	RAMP 3	124	S773	180	WT_FM	75
P393	276	Q108	179	RAMP 4	124	S773	186	WT_HS	75
P394	276	R1.5F	121	RAMP 5	124	S773	191	X25M	69
P396	276	R1.5FMR	121	RAMP 6	124	S773	208	XF	69
P397	276	R1.5OS	122	RAMP 7	125	S776	181	XG90KIT	182
P398	276	R1.5OSMR	122	RAMP 8	124	S776	186	XG900	182
P480	277	R1.5OSS	123	RAMP 8	125	S776	191	XG2212	138
P484	277	R1.5OSSMR	123	RAMP 9	124	S1125	156	XI	69
P490	276	R1.25F	121	RAMP 10	124	SA1	136	XK	69
P491	276	R1.25FMR	121	RAMP 11	124	SA2	136	XM	69
P493	276	R1.25OS	122	RAMP 12	124	SA3	136		
P497	276	R1.25OSMR	122	RAMP 13	125	SA4	136		
PDLAA	190	R1.25OSS	123	RAMP 14	125	SBR1F	128		
PDLBRKT	190	R1.25OSSMR	123	RR1	128	SBR1FMR	128		
PDL-D1	190	R1.75F	121	RR1.25FMR	129	SBR.5F	128		
PDL-D2	190	R1.75FMR	121	RR2	128	SBR.5FMR	128		
PEMKOSFSET	184	R1.75OS	122	RS138	78	SDL	255		
PEMKOSTCSET	204	R1.75OSMR	122	RS175	78	SHS80	198		
PF2x6KIT	233	R1.75OSS	123	RVAR1/A	125	SHS80	211		
PF134 KIT	233	R1.75OSSMR	123	RVAR1/AK	125	SIM100	217		
PF28200A	233	R1F	121	RVARIOSS	125	SIM150	252		
PFAS	233	R1FMR	121	S44	180	SIM150-BOLTKIT	252		
PFAS88	233	R1OS	122	S44	186	SIM150-LOCKKIT	252		
PFAS100	233	R1OSMR	122	S44	191	SIM200A	217		
PFBG-4	233	R1OSS	123	S44	208	SIRLH /SIRRH	219		
PFBG-4	256	R1OSSMR	123	S52	179	SOFT CLOSE	257		
PFBG-8	233	R2.25F	121	S77	181	SPFM	72		
PFBG-8	256	R2.25FMR	121	S77	186	SPFM_SLF	72		

ABOUT THE PEMKO PRODUCT LINE

Since 1952, the Pemko name has been known as a key manufacturer in weatherstripping products. Over the years, as an ASSA ABLOY Group brand, we have expanded our product line into a full line of architectural door trim products to include thresholds, fire/smoke gaskets, door bottoms, perimeter gasketing, brush seals, astragals, continuous geared and stainless steel hinges, fire and life-safety products, lites and louvers, and sliding door hardware.

The Pemko product line offers offers sound-tested, smoke-labeled, fire-labeled, skid resistant, and ADA-compliant products, and aggressively pursues new product development to create solutions for new applications and requirements.

Applications

- **Energy Efficiency:** These products make a complete energy efficient door solution – door bottoms, astragals, meeting stiles, brush gasketing, perimeter gasketing, and thermal barrier thresholds.
- **Smoke and Fire Gasketing:** Hot Smoke Seal™ is an intumescent fire life-safety product that meets UBC7-2 (proposed UL10C) positive pressure testing. Pemko S88 and S773 silicone seals are also smoke and fire rated gaskets that meet UBC7-2 positive pressure testing and are Category G gaskets for edge sealing systems for use with Category B doors.
- **Pemko Acoustic Solutions:** As a result of extensive acoustic testing, our gasketing systems are used on openings with STC Ratings from the low-30's and into the mid-50's. Acoustic seal sets have been assembled to better assist with determining an operable rating when a door's sealed-in-place rating is known. See pages 222 to 224 for more info.
- **Electrically Modified Pemko Hinges:** Continuous geared hinges are designed for commercial doors of all traffic levels and offer many benefits for your opening. All of our commercial-grade continuous geared hinges have the added option for electrical modification. Some of these options allow for electrical modifications to be made without removing the door from the opening.
- **ADA-compliant aluminum and rubber ramps** provide wheelchair access in public access doorways.
- **Sustainability:** Products are certified to GREENGUARD GOLD standards for low chemical emissions into indoor air during product usage.

All products in the Pemko line undergo rigorous testing to ensure that they meet or exceed the industry standards. Look for the logos next to the product drawings and see pages 12-13 for more information.



LEED Certification Contribution

ASSA ABLOY can help to achieve prerequisites and accumulate points in several categories and credit areas for LEED. For further information, please call 1-800-824-3018 or refer to our website to view our prepared LEED statement.



U.S. Green Building Council logo is a trademark owned by the U.S. Green Building Council and is used with permission.



ASSA ABLOY is a member of the USGBC and CaGBC

Sales & Support

Customer Service Representatives are available from 7am to 7pm Central time at 1-800-824-3018 or visit the website for the current catalogs, sell sheets, and the most up-to-date templates.

There are many items on the Pemko Quick Ship Program that ship within 48 hours. For the most up-to-date information, visit the Accessories WebShop at <https://accessories.assaabloy.com/en/accessories>. Customers with established Pemko accounts may request an account in WebShop through Pemko's Customer Service Representatives.

Need a Sales Rep?

Pemko is represented by the ASSA ABLOY Door Security Solutions team. Contact your local ASSA ABLOY Door Security Solution Representative via e-mail by going to www.assaabloydss.com and clicking on "Sales Support" or call 1-800-DSS-EZ4U (800-377-3948).

Website: www.assaabloydooraccessories.us

Facebook: www.facebook.com/ASSAABLOYARCHIT/

Twitter: @ASSAABLOYARCHIT

ASSA ABLOY has manufacturing and warehouse locations for the Pemko line in Memphis TN and Ventura CA. Each location offers a Will Call order pickup option for local customers. In Canada, we have a warehouse location in Toronto ON.

PEMKO
ASSA ABLOY

Experience a safer
and more open world

800-824-3018 | www.pemko.com
Check the web site for the up-to-date catalog

Copyright © 2015-2024, ASSA ABLOY Accessories and Door Controls Group, Inc., an ASSA ABLOY Group company. All rights reserved. Reproduction in whole or in part without the express written permission of ASSA ABLOY Accessories and Door Controls Group, Inc. is prohibited.

THE WEST COAST STOCKING PROGRAM

In an effort to better serve our customers in the western regions, we have expanded our collection of Pemko products available through our Ventura, California warehouse. Our West Coast Stocking Program includes a wide range of door accessories including thresholds, fire/smoke gaskets, door bottoms, perimeter gasketing, brush seals, astragals, continuous geared hinges, sliding door hardware, and more. All of the items in this catalog as well as their finishes are available in California.

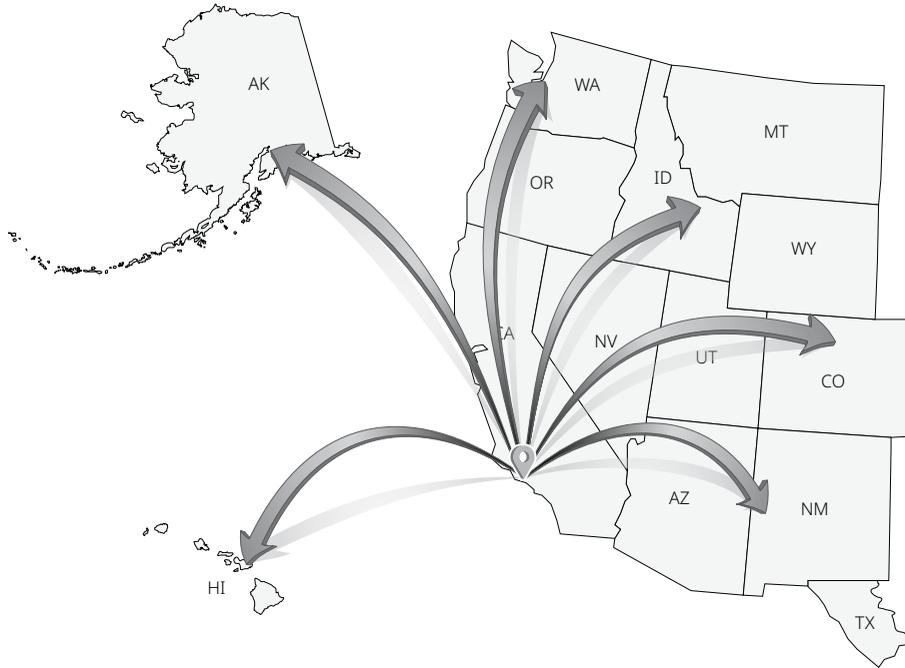

800-824-3018 | www.pemko.com

Check the web site for the up-to-date catalog

Copyright © 2015-2024, ASSA ABLOY Accessories and Door Controls Group, Inc., an ASSA ABLOY Group company. All rights reserved.
 Reproduction in whole or in part without the express written permission of ASSA ABLOY Accessories and Door Controls Group, Inc. is prohibited.

PEMKO
ASSA ABLOY

Experience a safer
 and more open world

GENERAL INFORMATION AND TERMS

Terms:

All prices are F.O.B. factory. To customers with satisfactory and / or prior approved credit and account status, terms of 1% 15 days, NET 30 days will be allowed. To open a new Pemko account, please contact your local Door Security Solutions Sales agency. Acceptance of orders and deliveries are subject to our approval.

Credit Card Capabilities:

Visa, Mastercard, Discover, and American Express are accepted (only for established open accounts). Payment terms are NET.

Freight Terms:

For freight policy terms & conditions please click [here](#) or see brand price book.

Oversized/Special Packaging:

\$100.00 NET. This will be added to any order not meeting prepaid freight where the product is a) over 10 feet in length, b) a welded threshold assembly, or c) as deemed appropriate to ensure product safety while in transit.

Minimum Order Level:

A surcharge of \$15.00 all will be added to NET orders less than \$100.00 NET.

Returns And Allowances:

No merchandise will be accepted for return or credit unless prior written approval is obtained. Returned merchandise must be of recent sale (6 months), in restockable / resalable quality, size, and condition. A minimum 25% charge plus freight charges will be made for returns. Material that is not in standard stock sizes, is made to special order, has a custom finish, or has been sold at special consideration or closeout is subject to additional charges. Foam tape is not returnable. Adhesive gasket may only be returned within six (6) months from the ship date.

Contact Customer Service for rules and Return Goods Authorization paperwork.

Cancellation Charges:

Cancellation of special order material, non-stock sizes, or special sizes are subject to cancellation charges, based on factory expense and material used.

Guarantee:

Pemko products are guaranteed for five (5) years against defects in material or workmanship, except: 1) PemKote abrasive surface for thresholds is guaranteed for ten (10) years. 2) Polyurethane foam tapes are guaranteed for 90 days. 3) Grade 1 PemkoHinges are guaranteed for the life of the opening against defects in material or workmanship. All other grades of PemkoHinge carry a ten (10) year warranty. 4) Electrical modification performance is guaranteed for five (5) years on Heavy Duty Grade 1 (HDI) and 1100 Series hinges. Electrical modification performance is guaranteed for one (1) year on Standard Duty and Heavy Duty Grade 3 (HD3) hinges. 5) PC Henderson products are guaranteed for two (2) years against defects in material workmanship. 6) Powder Coated finishes are warranted for two (2) years; normal wear is not included in coverage.

Markar Continuous Hinges and Pivots are guaranteed to be free from defects in materials and workmanship for a period of 10 years. Hinges with medical bearings are guaranteed for twenty-five (25) years. Markar Edge Guards and Astragals are guaranteed to be free from defects in materials and workmanship for a period of (1) year. Markar electrical modification performance is guaranteed for five (5) years.

Pemko Manufacturing Co. will not be liable for defects or damages arising from improper installation, product modification, incorrect application or storage of product. Written notice of damages must occur within the warranty period. Liability shall be limited to the replacement of product or component determined to be defective and shall not include costs arising from removal or reinstallation of product. Cost of replacement shall not exceed original purchase price. No other claims will be allowed. In no event shall liability be extended to include punitive, incidental or consequential damages arising from use of Pemko products. This is the sole warranty given by Pemko Manufacturing Co.. No other warranty implied or expressed shall be allowed.

Claims For Shortage Or Damage In Transit:

All claims must be made within ten (10) days of receipt of goods. Purchaser assumes the risk of loss or damage in transit.

Mill Lengths:

Most extrusions are available in mill lengths. Cut lengths over 12 feet are charged as mill lengths.



Experience a safer
and more open world

800-824-3018 | www.pemko.com
Check the web site for the up-to-date catalog

Copyright © 2015-2024, ASSA ABLOY Accessories and Door Controls Group, Inc., an ASSA ABLOY Group company. All rights reserved.
Reproduction in whole or in part without the express written permission of ASSA ABLOY Accessories and Door Controls Group, Inc. is prohibited.

GENERAL INFORMATION AND TERMS

Ordering Information:

Please order material by product number, specifying length required per piece and the number of pieces. Most weatherstrips are offered in standard sizes. If it is not practical to furnish the size ordered, the next larger size will be furnished and charged. Thresholds are maintained in standard sizes with 1/2" extra length on thresholds thru 47" and 1" extra length for thresholds 48" and longer to allow for fitting and field trim, unless exact net cut size is specified. Cut lengths under 24" will be charged as 24".

Thresholds, perimeter gaskets, astragals, and door bottoms are punched or drilled as standard, unless otherwise specified in this catalog. Material can generally be supplied without holes by stating "No Holes" on the applicable purchase order line.

Thresholds are punched with 12" centers. Thresholds over 8" in width will be punched with a double row. Thresholds are generally supplied with #10 flat head screws. Other fasteners are available on request.

Metal retainers for perimeter gaskets, door bottoms, and astragals are punched with 6" centers.

Non-Stock Finish Information:

Some items shown in this catalog are not stocked in certain finishes (i.e. BDG, G, PW, and SN). 'Batch charges' may be required on non-stock finishes to achieve our normally fast lead times. Contact Customer Service for a quotation and lead time.

Option Tables:

The option tables are provided for selection of other than standard or normal finishes, components, fabrication, or fasteners. Since these are other than standard or normal, please allow for extra lead time for option(s) selected.

Cutting Tolerances:

Elastometric: -0 + 2" (50.8mm)

Thresholds (up to 48"): + 1/2" (12.7mm)

Thresholds (48" and up): +1" (25.4mm)

Net Cut: +/- 0.060, 1/16" (1.5mm)

Hinges: +/- 0.032, 1/32" (0.8mm)

Automatic Door Bottoms: +/- 0.060, 1/16" (1.5mm)

Orders are subject to acceptance by Pemko Manufacturing Co. All prices and terms are subject to change without notice.

How to Order (Product Number Designations):

When placing your order, please specify the product profile number, finish, insert and size/length. Also make sure to clearly state any special fabrication needs, optional fasteners or custom finishes/sizes required.

Throughout the catalog, products are listed with an underscore (_) where variable finishes are available. More in-depth ordering information for specific lines is available in the individual product sections of the catalog.

Standard Products:

Example: 2005 A T 36 (Shown as 2005_T in catalog)

Profile#:	Finish:	Insert:	Size/Length:
2005	A	T = ThermoSeal	36 = 36"
216	SN	PK = PemkoPrene®	48 = 48"
297	BDG	V = Eco-V™	3684 = 1 piece @ 36" + 2 pieces @ 84"
303	A	S=Silicone	84/2 = 2 pieces @ 84"

Adhesive Gasketing Products:

Example: S773 D 21 (Shown as S773_ in catalog)

Profile#:	Finish:	Size/Length:
S773	D	21 = 21' coil
PK55	BL	510 = 510' (bulk packaging)
S88	W	17 = 17' coil

For PemkoHinge® and Modular Ramps, see detailed ordering information in their individual catalog sections.

800-824-3018 | www.pemko.com

Check the web site for the up-to-date catalog

Copyright © 2015-2024, ASSA ABLOY Accessories and Door Controls Group, Inc., an ASSA ABLOY Group company. All rights reserved.
Reproduction in whole or in part without the express written permission of ASSA ABLOY Accessories and Door Controls Group, Inc. is prohibited.

PEMKO
ASSA ABLOY

Experience a safer
and more open world

MATERIALS AND FINISHES INFORMATION

Metals:

Extruded metal products are made from 6063 aluminum alloy or CDA alloy C38500 architectural bronze (brass). Roll-formed metal products are made from steel, 70-30 yellow brass, or 85-15 red brass. Roll-formed aluminum weatherstripping is produced from various alloys selected for the particular properties required. See finishes information below for all finish designations. If you do not see the option you require, please inquire with our Customer Service Department about the feasibility of a custom finish.

Finish Designations:

A	- Mill Finish Aluminum	G	- Gold Anodized or Powder Coated Aluminum
AK	- Mill Finish Aluminum w/PemKote®	PW	- Painted White Aluminum
B	- Mill Finish Extruded Bronze (Brass)	S	- Cladded Stainless Steel
BK	- Mill Finish Extruded Bronze (Brass) with PemKote®	SN	- Satin Nickel Anodized or Powder Coated Aluminum
BDG	- Bright Dip Gold Anodized Aluminum	SP	- Galvannealed Steel
BSP	- Black Suede Powder Coat	SS	- Stainless Steel (see individual part for finish)
C	- Clear Anodized Aluminum	WSP	- White Suede Powder Coat
D	- Dark Bronze Anodized Aluminum	Z	- Steel Metal
		10BE	- Satin Bronze Powder Coat

Special Order Finishes:

Painted Aluminum (any color)	Powder Coating, Custom - Provide RAL#
Polished Aluminum, Uncoated	Satin Brushed Aluminum, Uncoated
Polished Bronze, Uncoated	Satin Brushed Bronze, Uncoated
	Oxidized and Oil Rubbed Bronze

Finish Options:

PemKote®
 Anodized (*clear, dark bronze, black*)
 Polish/Buf Brass
 Polish/Buf Aluminum
 Satin Buff Brushed Brass
 Oxidized & Oil Rubbed L-metal (ANSI/BHMA 722)
 Oxidized & Oil Rubbed L-metal (custom finish, 609, 613)
 Oxidized & Oil Rubbed Thresholds (ANSI/BHMA 722)
 Oxidized & Oil Rubbed Thresholds (custom finish, 609, 613)
 Oxidized & Oil Rubbed Weatherstrip (ANSI/BHMA 722)
 Oxidized & Oil Rubbed Weatherstrip (custom finish, 609, 613)

Adhesive Gasketing And Replacement Eco-V™ Finishes:

BL - Black
 C - Clear
 D - Dark Brown
 GR - Light Gray
 TAN - Tan
 W - White

Inserts:

Pemko Manufacturing Co. manufactures many products with gasket inserts (seals). See insert information below for all insert (seal) designations. Also, the available inserts (seals) for each individual product are shown adjacent to each individual product.

E - EPDM, Solid	PK - PemkoPrene®*	SB - Soft Brush
M - Magnetic	Q - Kerf-in Foam	T - ThermoSeal
N - Neoprene or EPDM	R - Sponge Neoprene or EPDM	TF - Triple Foam
NB - Nylon Brush	S - SiliconSeal or Sponge Silicone (see individual part)	V - Eco-V®
P - Pile		

*PK: In order to best control our customers' costs some PK (Santoprene™) products may be a silicon based elastomeric material with comparable performance.



Experience a safer
and more open world

800-824-3018 | www.pemko.com
Check the web site for the up-to-date catalog

Copyright © 2015-2024, ASSA ABLOY Accessories and Door Controls Group, Inc., an ASSA ABLOY Group company. All rights reserved. Reproduction in whole or in part without the express written permission of ASSA ABLOY Accessories and Door Controls Group, Inc. is prohibited.

Fabrication Options:

Pemko Manufacturing Co. offers many fabrication options for our products to fit specific job requirements. Please consult our Customer Service Department for details. Custom fabrications are subject to engineering design costs and are quoted on a time and material basis.

Bevel	One Edge	Miter2-1	Double, One End of Threshold
Cut	Thresho-Sill Nosing Flush	Miter2-2	Double, Both Ends of Threshold
Leadline	Leadline of Astragals, Door Bottoms	Half Notch	1/2", Door Shoe, Both Ends, Drip Only
Rip	Width	Half Notch	3/4", Door Shoe, Drip Only, Both Ends
Tack Weld	One Line	Half Notch	5/8", Door Shoe, Drip Only, Both Ends
Tab	Welded Tab & Screw	Half Notch	9/16", Door Shoe, Drip Only, Both Ends
Support Leg	For Elevated Plates 3" Center to Center	Full Notch	1/2", Door Shoe, Both Ends
L-Notch	Both Ends of Threshold	Weep Holes	All Door Shoes
U-Notch	Both Ends of Threshold	Custom Holes	Custom Hole Pattern
Drill	Thresho-Sill (Add "H" to Prod. #)		
Mill & Drill	Thresho-Sill (Add "M" to Prod. #)		
Miter1-1	Single, One End of Threshold		
Miter1-2	Single, Both Ends of Threshold		

Fabrication Options Important Note: Complicated fabrications are quoted based on time and materials.

Drawings:

Product drawings throughout the catalog may be a reduced representation/not drawn to scale. They are representations of the product size, dimensions, shape, etc. For scale drawings in PDF or AutoCAD (DWG or DXF) format, please visit our website: www.pemko.com

PRODUCT TESTING/CLASSIFICATION SYMBOLS

These symbols are shown adjacent to products throughout the catalog so that one can readily identify and select products which meet specification and/or code requirements.



GREENGUARD GOLD Certification:

Tested To: UL2818

GREENGUARD GOLD Certified products are certified to GREENGUARD GOLD standards for low chemical emissions into indoor air during product usage. For more information, visit ul.com/gg or spot.ul.com for Pemko's GreenGuard listing.



Air Infiltration Tested

Tested To: ASTM E-283-04 (2012)

Products indicated by this symbol have been air infiltration tested in accordance with the requirements of ASTM E-283 Rate of Air Leakage Through Exterior Windows, Curtain Walls, and Doors.



Sound Tested

Tested To: ASTM E 90-2009

Products indicated by this symbol have been acoustically tested in accordance with ASTM E 90-2009. Method for Laboratory Measurement of Airborne Sound Transmission Loss of Building Partitions Tests were conducted by accredited laboratories for acoustic testing. Contact your Door Security Solutions Sales rep or Pemko Customer Service for recommended PEMKOSTCSET kits.



Barrier-Free

Meets Requirements of: ADAAG-2010 (Amended) and ICC / ANSI A117.1-2017

Products indicated by this symbol are access compliant by having installed height differences not over 1/2" with allowable edge and slope conditions. All ramp products (found in the Modular Ramp section) have ADA compliant 1:12 slopes: Pemko Modular Ramp Thresholds, Rubber Ramp Thresholds and Recycled Rubber Ramps. Contact Pemko Manufacturing or refer to page 14 for recommended Barrier-Free Systems.

800-824-3018 | www.pemko.com

Check the web site for the up-to-date catalog

Copyright © 2015-2024, ASSA ABLOY Accessories and Door Controls Group, Inc., an ASSA ABLOY Group company. All rights reserved. Reproduction in whole or in part without the express written permission of ASSA ABLOY Accessories and Door Controls Group, Inc. is prohibited.



Experience a safer and more open world



Non-Skid/PemKote™

Meets Requirements of: ASTM D 2047, UL 410 & Federal Specifications P-F-430C

PemKote™ is a rugged abrasive finish of nickel-aluminum composite which is fused to the metal surface by an exothermic reaction. This process produces an aesthetically pleasing skid resistant coating with extremely high bond strength and excellent resistance to oxidation. PemKote™ carries a TEN (10) YEAR GUARANTEE, and is available on all Pemko line metal thresholds and metal modular ramps. ASSA ABLOY highly recommends the use of PemKote™ for all Barrier-Free Modular Ramps and as a durable, economical alternative for cast abrasive products.



Smoke Tested

Tested To: UL 1784

Meets Requirements of: NFPA 105-2013

Products indicated by this symbol are Listed by WYLE Laboratories as having been tested in accordance with Underwriters Laboratories Inc.®, Standard UL 1784 Air Leakage Tests of Door Assemblies, and meet the performance criteria for allowable air leakage as specified in NFPA 105-2013 Installation of Smoke Control Door Assemblies.



Fire Rated

Products indicated by this symbol are fire rated, classified and listed (U.S.A. and Canada) to meet the requirements/standards of UL10B, UL10C, and UL10C (Edge Sealing). For a complete listing of fire rated and UL listed products, please refer to the UL Product Directory website, <https://iq2.ulprospector.com>.



PemkoHinge® Rating:

All hinge models designated with these symbols are tested by Underwriters Laboratories Inc.® (U.S.A. and Canada) to standards UL10B and UL10C for up to a 3-Hour Fire Listing for all 4'-0" x 10'-0" and 8'-0" x 10'-0" door and frame assemblies. Fire listing certifications apply to all approved hollow metal and wood door assemblies in drywall or masonry wall construction. Check UL File #R14745 on the UL website for a complete and current listing of applicable PemkoHinge® products.



Builders Hardware Manufacturers Association:

Products indicated by this symbol have been voluntarily submitted to rigid third party testing and follow-up audits to confirm that they fully and continuously meet or exceed the requirements of their underlying ANSI / BHMA Standards. These products are listed in the BHMA Certified Products Directory. They are also posted and frequently updated on the BHMA website at www.buildershardware.com. Pemko products are covered by the following: ANSI / BHMA A156.21 Standard for Thresholds, ANSI / BHMA A156.22 Standard for Door Gasketing Systems, and ANSI / BHMA A156.26 Standard for Continuous Hinges.



UL1S47 - Check UL File #R18375 on the UL website for a complete and current listing of applicable Pemko edge sealing and fire glazing products (not specifically listed by item in this product catalog).



UL4L10 - Check UL File #R14369 on the UL website for a complete and current listing of applicable Pemko line products (not specifically listed by item in this product catalog).



Check Pemko's Category G, Category H and Category J listings on ITS website www.intertek.com for a complete and current listing of applicable Pemko edge sealing, perimeter gasketing and fire glazing products.



Experience a safer and more open world

800-824-3018 | www.pemko.com
Check the web site for the up-to-date catalog

Copyright © 2015-2024, ASSA ABLOY Accessories and Door Controls Group, Inc., an ASSA ABLOY Group company. All rights reserved. Reproduction in whole or in part without the express written permission of ASSA ABLOY Accessories and Door Controls Group, Inc. is prohibited.

BARRIER-FREE SYSTEMS



Pemko product lines include many products such as modular ramps, thresholds and floor treads, that help you meet the requirements of the Americans with Disabilities Act (ADA) as outlined in the Americans with Disabilities Act Accessibility Guidelines (ADAAG-2010 amended); ICC /ANSI A117.1 Standard Accessible and Usable Buildings and Facilities; any of the various Uniform Building Codes; or state access codes (e.g. California Building Code, Title 24).

The following table shows which products comply with the ADAAG and ICC /ANSI standard and also notes their respective sections.

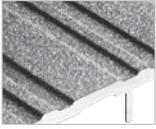
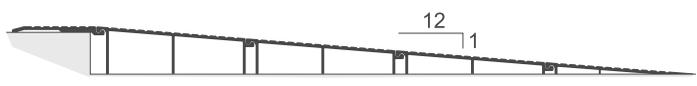
ICC / ANSI A117.1 (ADAAG)	Pemko Recommendation	
<p>302 (4.5) Floor or Ground Surfaces. 302.1 (4.5.1) General. "shall be slip resistant"</p>  <p>Skid resistant.</p>	<p>"Slip resistant" PemKote™, non-skid surface</p> <ul style="list-style-type: none"> • PemKote™ (finish code: "K") is a rugged abrasive finish of nickel-aluminum composite • PemKote™ provides safety in environments used by youths and people with disabilities • For more information, see the Modular Ramps section 	 <p>PemKote™: skid resistant surface.</p>
<p>302.2 (4.5.3) Carpet. "Exposed edges of carpet...shall have trim along the entire length of the exposed edge. Trim shall comply with Section 303"</p>	 <p>Note: See Commercial Thresholds section (page 136) for more options.</p>	
<p>303 (4.5) Changes in Level 303.2 (4.5.2) Vertical. "Changes in level of 1/4" (6mm) high maximum shall permitted to be vertical"</p>	 <p>Note: See Commercial Thresholds section (pages 134-135) for more options.</p>	
<p>303.3 (4.5.2) Beveled. Changes in level greater than 1/4 inch (6.4 mm) in height and not more than 1/2 inch (13 mm) maximum in height shall be beveled with a slope not steeper than 1:2."</p>	 <p>Note: See Commercial Thresholds section (pages 106-129) for more options.</p>	
<p>303.4 (4.5.2) Ramped. "Changes in level greater than 1/2" (13mm) shall be by a ramp complying with Section 405 (4.8)"</p>	<ul style="list-style-type: none"> • Assemblies accommodate 1/2" to 2 1/4" floor offsets in meeting the 1:12 slope requirements of the "Americans with Disabilities Act" • Rubber ramp component assemblies meet the same requirements. • Answer the needs of architects, specifiers, building owners, installers, and physically challenged people • For use in schools, hospitals, stadiums, offices, restaurants, hotels, airports, and more • For complete information, see the Modular Ramps section 	
<p>404 (4.13) Doors, Doorways and Gates. 404.2.4 (4.13.8) Thresholds. "...shall be 1/2" high maximum...shall comply with Sections 302 and 303"</p>	 <p>Note: See Commercial Thresholds section (pages 106-129) for more options.</p>	
<p>404.2.8 Door and Gate Opening Force - 5lbs. maximum</p>		
<p>405 (4.8) Ramps 405.2 (4.8.2) Slope. "Ramp runs shall have a running slope... not steeper than 1:12" <i>(Note: Some exceptions apply to this with respect to existing buildings having space limitations. Consult Pemko for specific applications.)</i></p>	 <p>Note: See Modular Ramp section (pages 142-146) for more options.</p>	
<p>504 (4.9) Stairways 504.4 Tread Surface 504.5 (4.9.3) Nosings</p>	  <p>Note: See Floor Treads section (pages 132-133) and Floor Molding, Trim section (page 284) for more options.</p>	

800-824-3018 | www.pemko.com
Check the web site for the up-to-date catalog

Copyright © 2015-2024, ASSA ABLOY Accessories and Door Controls Group, Inc., an ASSA ABLOY Group company. All rights reserved.
Reproduction in whole or in part without the express written permission of ASSA ABLOY Accessories and Door Controls Group, Inc. is prohibited.

PEMKO
ASSA ABLOY

Experience a safer
and more open world

ANSI/BHMA 

The following interprets ANSI/BHMA numbers which identify material and type of products. For products that meet ANSI/BHMA Standards, look for the BHMA certified logo next to the product in our catalog. For a complete listing refer to the BHMA Certified Products Directory on line at www.buildershardware.com.

American National Standard for Thresholds ANSI/BHMA A156.21 (2019)

1 Product Section "J" Designates Architectural Door Trim, Thresholds				
2 Material	3 Configuration	4 Surface	5 Description	6 Description
1. Architectural Extruded Brass or Bronze 3. Aluminum 5. Stainless Steel 7. Rubber & similar nonmetallic 0. Other (ie: cast iron, safety abrasive, etc.)	1. Compressing top 2. Flat Saddle 3. Half Saddle 4. Interlocking 5. Rabbeted, Latching/Panic with Gasket 7. Plate 8. Ramped 9. Saddle for Floor Closer 0. None designated	1. Fluted 2. Fluted with abrasive 3. Smooth 4. Smooth with abrasive	1. Applied Stop 2. Applied Stop with gasket 3. Barrier Free 4. Carpet Separator 5. Ends Mitered 6. Expansion Assembly 7. Hook Strip Applied to door 8. Offset 9. Thermal Break 0. None Designated	1. Applied Stop 2. Applied Stop with gasket 3. Carpet Separator 5. Ends Mitered 6. Expansion Assembly 7. Hook Strip applied to door 8. Offset 9. Thermal Break 0. None Designated

Suffix "-HD" designates thresholds meeting Heavy Duty requirements

American National Standard for Door Gasketing and Edge Seal Systems ANSI/BHMA A156.22 (2021)

1 Product Section "R" Designated Gasketing					
2 Product Material	3 Gasketing Material		4 Product Type	5 Material Application	6 Gasketing Rating
1. Brass or Bronze 3. Aluminum 5. Stainless Steel 0. Optional material or none used	A. Brush B. Neoprene, solid C. Neoprene, closed cell D. Vinyl/Eco-V™ E. Silicone Rubber F. Pile G. Thermoplastic Elastomer (TPE) H. Thermoplastic Urethane (TPU) J. Thermoplastic Rubber K. Spring Metal L. Magnetic M. Felt N. Rubber Fabric P. Intumescent Q. Intumescent/Brush	R. Intumescent/Neoprene, Solid S. Intumescent/Neoprene Closed Cell T. Intumescent/Vinyl U. Intumescent/Silicone Rubber V. Intumescent/Pile W. Intumescent/Thermoplastic (TPE) X. Intumescent/Thermoplastic Urethane (TPU) Y. Optional material or none used Z. Intumescent/Thermoplastic Rubber	1. Head and Jamb 2. Head and Jamb, Adjustable 3. Automatic Door Bottom 4. Door Sweep or Shoe 5. Door Sweep or Shoe with Drip Cap 6. Astragal Overlapping 7. Astragal Split or Compensating 8. Astragal Adjustable 9. Rain Drip without gasket 0. Other	1. Door Edge 2. Door Edge, Mortise 3. Door Face 4. Door Face, Semi-Mortise 5. Frame Rabbet (surface or mortise) 6. Frame Soffit (H.M.) Frame Stop (W.D.) 7. Frame Face 8. Kerf 9. Stop (H.M.), Stop Face (W.D.) 0. Other	0. Smoke/Energy Performance/Acoustic Rated 1. Smoke/Energy Performance Rated 2. Smoke/Acoustic Rated 3. Energy Performance/acoustic Rated 4. Smoke Rated 5. Energy Performance Rated 6. Items not Rated 7. Acoustic Rated

American National Standard for Continuous Hinges ANSI/BHMA A156.26 (2021)

First letter denotes BHMA Product Section (A)

First Numeral-Product Material	Second Numeral-Type of Product	Third Numeral-Electrical Modifications	Fourth Numeral-Door Weight (lbs)	Fifth Numeral-Grade Classification	Second Letter-Hinge Type
1. Brass, Bronze 3. Aluminum 5. Stainless Steel 8. Steel	1. Edge Mounted Hinges 2. Half Edge Mounted Hinges 3. Full Surface Hinges 4. Half Surface Hinges 5. Swing Clear 6. Raised Barrel 7. Wide Throw 0. Other	0. None 1. Concealed Wire Transfer 2. Monitor 3. Power Transfer 4. Other	1. 150 2. 300 3. 600 4. 1200	1. Grade 1 2. Grade 2 3. Grade 3	B. Barrel G. Geared



Experience a safer and more open world

800-824-3018 | www.pemko.com
 Check the web site for the up-to-date catalog

Copyright © 2015-2024, ASSA ABLOY Accessories and Door Controls Group, Inc., an ASSA ABLOY Group company. All rights reserved. Reproduction in whole or in part without the express written permission of ASSA ABLOY Accessories and Door Controls Group, Inc. is prohibited.

MARKAR CONTINUOUS PIN AND BARREL HINGES

CONTENTS:

General Information.....	18
Hinge Finishes	20
Hinge Numbering System and Standard Lengths	21
Continuous Hinge Modifications	22
3500 Series Stainless Steel Pin and Barrel Security Hinges	25
600 Series Stainless Steel Pin and Barrel Hinges	29
300 Series Stainless Steel Pin and Barrel Hinges	30
300 Series Stainless Steel Edge Guards.....	45
200 Series Carbon Steel Pin and Barrel Hinges.....	48
100 Series Aluminum Pin and Barrel Continuous Hinges	50
900 Series Toilet Partition Hinges	52
400 Series Toilet Partition Hinges	54
Pivots.....	56
Flat Astragals	57
Fasteners and Fastener Packs.....	59
Tools, Parts, and Accessories.....	63
Custom Lengths	64

INDEX:

PRODUCT	PAGE	PRODUCT	PAGE	PRODUCT	PAGE
B1923.....	56	FM400	54	FS/SC309	38
EG308.....	45	FM600	29	HG305	37
EGC308	46	FM900	52	HG310.....	39
EGT308	47	FM3500	25	HG311.....	40
FA68	57	FS102	51	HG315.....	41
FA70	57	FS301	33	HG323	42
FA80	57	FS302.....	34	HG326	43
FM100.....	50	FS402.....	55	HG329	44
FM200.....	48	FS902.....	53	HG3505.....	28
FM300	30	FS910	53	HM304.....	36
FM300WT	31	FS3501.....	26	HS203	49
FM300WT	32	FS3502.....	27	HS303.....	35

NOTE: Products shown in this section may not be drawn to scale



MARKAR CONTINUOUS PIN AND BARREL HINGES

Markar has been a leader in innovative products for the hardware industry since 1969. In 1983, Markar was the first manufacturer to produce an architectural grade, adjustable continuous pin and barrel hinge line, and that innovation continues today with quality continuous hinges and edge guards. Markar leads the industry in development of fire rated continuous hinges with their flagship 300 Series Stainless Steel, 3500 Series institutional grade, and 200 Series cold rolled steel hinges. Building on customer feedback, Markar has developed over 75 standard continuous hinge models providing products for a wide variety of applications and challenges.

Custom Designs

Whether the need is for a custom color to match a specific palette, hospital tips for patient rooms, hardware cutouts, wide throw models, custom hole patterns, security fasteners, current transfers, monitoring switches, or medical bearings, Markar hinge modifications will enhance the fit and function of an opening. Markar hinges are available in a wide range of finishes including powder coat, anodized (for aluminum), and architectural finishes.

Medical Bearings are Standard

Medical Bearings are standard for all Pin and Barrel hinges. You benefit from this standard offering with permanently lubricated hinges with no metal to metal contact, improving the life and overall function of the hinge.

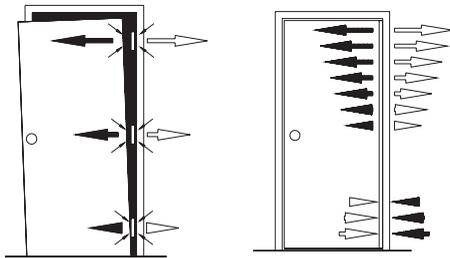

Most door and frame stress is put on the top of conventional hinge systems.

A continuous hinge spreads the stress along the full length of the door and frame.

WHY CONTINUOUS HINGES?

Did you know that on a door with traditional butt hinges, 70% of the door weight is on the top hinge? The top hinge also bears the brunt of abuse when doors are opened beyond the stop device, resulting in kickback shock and eventual failure of the hinge and damage to the frame. This is why continuous hinges are recommended for heavy doors and for situations where doors are exposed to misuse.

Continuous hinges reduce the factors leading to hinge failure by distributing weight evenly so wear and tear to the frame and door is reduced significantly.

In addition, continuous hinges:

- Increase security and reduce vandalism by preventing insertion of devices between the door and frame
- Ease installation by providing simple alignment of electrical transfers and of monitoring switches
- Reduces air infiltration by creating a complete seal from top to bottom of the door at the hinge jamb

Markar manufactures pin and barrel hinges as well as spring loaded toilet partition pin and barrel models. There are over 75 different models to choose from offering a variety of configurations, options, and materials.

Optional Features

The Unique Adjust-A-Screw™ Fastener

An optional Markar fastener available on Hinge Guard models permits up to 3/8" width adjustment. Full door length adjustment means doors can be squared accurately and easily in new installations and existing frames can be used in retrofits. Maintenance staff can make future adjustments of the door by re-positioning the Adjust-A-Screw™ Fasteners.

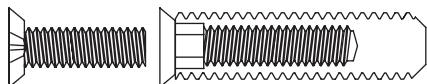

Adjust-A-Screw™ Assembly

One full turn of the Adjust-A-Screw™ adjusts the width of the door and hinge assembly 1/16".

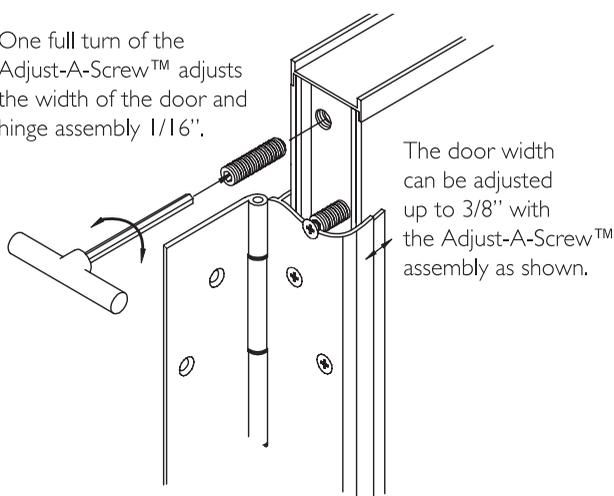

Recommended 14 gauge reinforcements on frame and door. If using an adjustable Hinge Guard with Adjust-A-Screw, use 14 gauge reinforcements on frame and 12 gauge reinforcements on door.

For more information, including technical memos, door clearance guides and templates visit <https://www.assaabloydooraccessories.us/en/>

Exclusive Fiber-Reinforced Polymer Bearings

- Uniquely designed to provide clean and quiet hinge operation
- Self lubricating with high resistance to wear
- Exceeds ANSI/BHMA Grade 1 requirements
- 25 year warranty

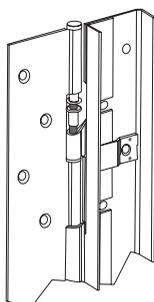

800-824-3018 | www.pemko.com

Check the web site for the up-to-date catalog

Copyright © 2015-2024, ASSA ABLOY Accessories and Door Controls Group, Inc., an ASSA ABLOY Group company. All rights reserved. Reproduction in whole or in part without the express written permission of ASSA ABLOY Accessories and Door Controls Group, Inc. is prohibited.

Windstorm Rated Hinges

Windstorm/hurricane testing on Markar continuous hinges was completed with UL and has been reviewed and approved to meet the requirements of the Florida Building Code (FBC). These hinges have passed tests for the following: an Impact Test (TAS 201), Static Load/Cyclical Test (TAS 202), and a Water and Leakage Test (TAS 203). Markar excelled in all three categories of testing.

Based on this performance, the FBC approved most Markar hinges in the following series:

(Up to openings of 4'0 x 8'0 singles and 8'0 x 8'0 pairs)

- 100 – 6063-T6 Aluminum
- 200 – 14 ga. Cold Rolled Carbon Steel
- 300 – 14 ga. 304 Stainless Steel
- 600 – 14 ga. 316 Stainless Steel
- 3500 – 12 ga. 304 Stainless Steel (Security Grade)



Tornado



Hurricane



Fire Rated Continuous Hinges

Markar Stainless Steel hinges (300 Series and 3500 Series) and carbon steel hinges (200 Series) are available with two labeling options: Underwriters Laboratories Inc. or Warnock Hersey Int'l.

- 20 minute labeled wood doors
- One and a half hour labeled hollow metal and composite-core wood fire doors
- Three hour labeled hollow metal doors

Maximum Door Opening:

Single Doors: 4'0" x 10'0"

Pair of Doors: 8'0" x 10'0"



In accordance with UL10C for positive pressure.

Behavioral Health Hinges

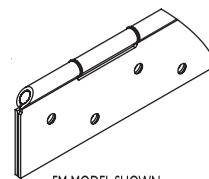

PEMCO
ASSA ABLOY

Experience a safer
and more open world

STANDARD POWDER COAT FINISHES

Tough, Durable, Long-Lasting

Designed for general purpose interior and exterior use and applications where maximum chemical and solvent resistance is required.

Performance Properties

The data below is based on 24 gauge Bonderite 1000 panels with 1.5 mil to 2.0 mil of high gloss formulation.

Adhesion (ASTM D-3359B): There is no lifting of 1/8" squares of coating between scribed lines in crosshatch adhesion testing using pressure sensitive adhesive backed tape.

Pencil Hardness (ASTM D-3363): 2H – 4H

Flexibility (ASTM D-522 modified): The coating withstands a 180° bend over a 1/4" diameter mandrel without cracking or loss of adhesion.

Impact Resistance (ASTM D 2794 modified): The coating withstands 160 inch-pound impacts, both direct and reverse, without cracking or loss of adhesion using the standard Gardner impact tester.

Abrasion Resistance (ASTM D-4060 modified): The weight loss of coating after 1,000 cycles on a Taber abraser equipped with CS-10 wheels and operating under a 1 kilogram loading per wheel is on the order of 35 to 50 milligrams.

Salt Spray Resistance (ASTM B-117): Bonderite 1000 steel panels, in a scribed condition, exhibit no undercutting after 1,000 hours in 5% salt spray testing at 95°F and 95% relative humidity. There was no rusting or blistering on the panel face away from the scribe.

Humidity Resistance (ASTM D-2247): Bonderite 1000 steel panels in an unscribed condition exhibit no effect after 1000 hours exposure to 100% relative humidity at 100°F.

Chemical and Solvent Resistance: After 60 days immersion in the test fluid, the following data was obtained for epoxy powder coatings:

15% Hydraulic Acid	No Effect
Lacquer Thinner	No Effect
Dilute "HTH" Pool Chemical	No Effect
15% Sulfuric Acid	Pinhole Rust
15% Caustic Soda	#8 Blisters
Ammonia Hydroxide	#8 Blisters
Petrochloroethylene	No Effect
15% Acetic Acid	#4 Blisters
Gasoline	No Effect

Verification of resistance properties should be made for each chemical or solvent proposed for use with the coating.

Closest US Standard & BHMA Finishes

No minimum quantity.

PC-1	Dark Oxidized Satin Bronze	10BE
PC-2	White Suede	714
PC-3	Black Suede (BSP)	693
PC-4	Aluminum	689
PC-5	Sun Gold	706
PC-6	Light Copper	691
PC-7	Polished Brass	605

PC-7 available only on 100 & 300 series hinges

*NOTE: The PC-7 will have an additional charge for two-step polishing process.

Special Finishes

Polished Aluminum	US26	672
Polished Stainless	US32	629
Kynar Paint	With Color Approval	

*NOTE: Additional setup charges will apply.

Special Anodized Finishes

Gold Anodized	US3	310
Light Bronze Anodized	US9	311
Medium Bronze Anodized		312
Black Anodized	US19	315

Custom Powder Coat Finishes

All RAL Powder Coat finishes available. Sample color chip must accompany order. Priced at time of order.

U.S. Standard & B.H.M.A. Finish Codes

US3	310	gold anodized
US9	311	light bronze anodized
	312	medium bronze anodized
US20A	313	dark bronze anodized
US19	315	black anodized
USP	600	primed for paint
US2G	603	zinc plated
US28	628	clear anodized
US32	629	bright Stainless Steel
US32D	630	satin Stainless Steel
US26	672	bright polished aluminum
US28	689	aluminum paint
US20A	690	dark bronze paint
US10	691	light bronze paint
US19	693	black paint
US4	706	gold paint
	714	white paint



Experience a safer
and more open world

HINGE NUMBERING SYSTEM

Hinge Prefixes

EG	Edge Guard
FM	Edge Mount
FS	Full Surface
HG	Hinge/Guard
HM	Half Mortise
HS	Half Surface
SC	Swing Clear

Hinge Series

This series number indicates the type of hinge and base material used:

100	Aluminum barrel hinges with stainless pin
200	Carbon steel barrel hinges with stainless pin
300	Stainless steel barrel hinges with stainless pin
400	Spring loaded aluminum toilet partition hinge
600	14 Gauge 316 stainless steel pin and barrel security hinges
900	Spring loaded stainless steel toilet partition hinges
1900	Reinforcing pivots
3500	12 Gauge stainless steel pin and barrel security hinges

Hinge Models

The last two digits of the model number indicate the application:

00	Edge mount (formerly full mortise)
01	Full surface, 1/8" offset
02	Full surface, flush
03	Half surface, 1/8" offset
04	Half mortise, 1/8" offset
05	Edge mount hinge/guard
06	Half mortise hinge/guard
07	Double hinge/guard
08	Edge guard
09	Full surface, swing clear
10	Swing clear hinge/guard
11	Edge mount, self aligning
15	Edge mount, self aligning flush edge guard
21	Full surface inset, 3/4" offset
22	Edge mount hinge/guard, deep
23	Edge mount hinge/guard, deep, thru bolt
25	Edge mount swing clear
26	Edge mount hinge/guard, swing clear
27	Edge mount, safety hinge
29	Edge mount, self aligning

Other numbers are used for specific applications

Optional Suffixes

AMS	Adjustable Monitoring Switch
CTP	Current Transfer Preparation
DDP	Dutch Door Prep
EL	ElectroLynx® Wires (Specify 4, 8, or 12)
ETAP	Electrical Transfer Access Prep
EPT	Electric Power Transfer
HT	Hospital Tip
LL	Lead Lined
PC	Powder Coated
RB	Raised Barrel
WT	Wide Throw
PoE	Power over Ethernet

Hinge Standard Lengths

Standard Hinge Length Conversion Chart

A 6'8"	door opening	=	actual length	79 ^{3/16} "
A 7'0"	door opening	=	actual length	83 ^{1/8} "
A 7'2"	door opening	=	actual length	85 ^{1/8} "
A 8'0"	door opening	=	actual length	95"
A 10'0"	door opening	=	actual length	118 ^{3/4} "

Custom hinge length will be evaluated at the time of request to ensure proper pin to knuckle alignment. Some custom length requests may be adjusted to ensure a proper hinge assembly. Specify handing on all custom hinge lengths.

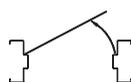

LEFT HAND

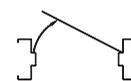

RIGHT HAND

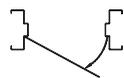

LEFT HAND
REVERSE



RIGHT HAND
REVERSE

CONTINUOUS HINGE MODIFICATIONS

Special Length

Please specify handing on all custom hinge lengths
Some custom lengths may require two cuts due to location of screw holes

Hospital Tip

Available on all models except spring-loaded toilet partition hinges.
Handing needed on some models and all cut down lengths.
Suffix hinge "-HT"
Helps provide a safe, clean environment

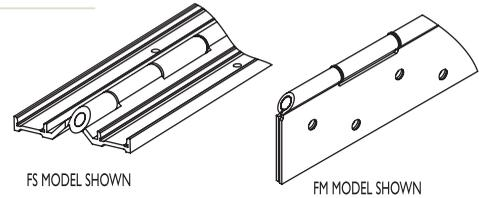

Dutch Door Prep

Available on all hinge models
Suffix hinge "-DDP"
Continuous frame leaf with two-piece door leaf
Indicate handing, clearances, door and frame heights, and materials when ordering

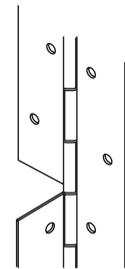

Wide Throw

Only available on 300 and 3500 series hinges
Markar Custom Hinge Information Form must be filled out
Reinforcement may be required on extreme wide throw applications
These conditions will be determined through a drawing approval process

Blank

Holes omitted for special applications, such as welded installation
Not available on adjustable models

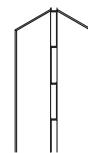

Welded End Pins

End pins are tack-welded and are non-removeable
Not available on aluminum, powder coated hinges and 200 series hinges

Plug Weld

Plug welding hole prep

Automatic Door Bottom Cut

Standard "U" shape cut accepts most automatic door bottoms
Make and model are needed

Removable Auto Door Bottom Prep (RADBP)

Auto door bottom cut out with cover plate

- FMPLATE (FM300, HM304)
- HGPLATE (HG311, HG315, HG329)
- HGADJPLATE (HG305, HG310, HG326) FM3500PLATE (FM3500)

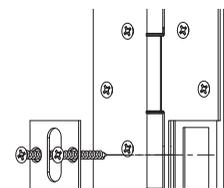

Experience a safer
and more open world

CONTINUOUS HINGE MODIFICATIONS (CONT.)

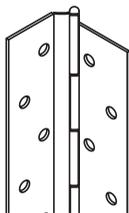

Raised Barrel (Swaged)

Available on all edge mount, half surface, and half mortise models except on aluminum hinges

Suffix hinge "-RB"

For cased open or center pivot doors



Standard Edge Guard Cut-Outs

The Edge Guard Order form must be filled out to properly locate the hardware cut-outs

4⁷/₈" ASA strike

161 latch

161 strike

86 mortise

Manual flush bolt

Automatic flush bolt

Fire bolt

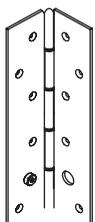

Security Studs

Stainless Steel security studs mounted to the frame leaf

Door leaf is drilled to accommodate studs

Three studs installed on hinges up to 7'2"

Four studs installed on hinges over 7'2"

Door and frame must be specially prepared to accommodate security studs

Custom Design

The engineering department will assist you in developing custom applications to solve any of your unique door hinging problems. This includes Sheared Leaf or Custom Hole Pattern modifications.

Markar Custom Hinge Information Form must be filled out

Lead Lined (Standard 4 Lbs./SQ.FT.)

Used for X-ray room doors and other locations where radiation leakage could be a problem

Available on surface mounted hinges and Markar EGT308 edge guard

CONTINUOUS HINGE MODIFICATIONS *(Cont.)*

EL ElectroLynx® Current Transfer

EL4 For 300, 3500, 200, and 100 series edge mount only.
 2 wires at 22 gauge and 2 wires at 26 gauge - with ElectroLynx® connectors (4 wire)
 EL8 For 300, 3500, 200, and 100 series edge mount only.
 2 wires at 22 gauge and 6 wires at 26 gauge - with ElectroLynx® connectors (8 wire)
 EL12 For 300, 3500, 200, and 100 series edge mount only.
 2 wires at 22 gauge and 10 wires at 26 gauge - with ElectroLynx® connectors (12 wire)
 *We recommend an Electrical Transfer Access Prep (ETAP) with all ElectroLynx® modifications
 Replacement wire harness available (EL4-REPLKIT, EL8-REPLKIT & EL12-REPLKIT)

ElectroLynx®
 As part of their promise to provide innovative, fast and effective high security solutions to their customers, certain ASSA ABLOY Group brands offer *ElectroLynx®*, a universal quick-connect system that simplifies the electrification of the door opening.
ElectroLynx® is a registered trademark of ASSA ABLOY Inc.

PoE (Power over Ethernet) ElectroLynx® Power and Data Transfer

PoE for most 3500, 600, 300, 200 and 100 series edge mount continuous hinges- with ElectroLynx® connectors (9 wire). Electrical Transfer Access Prep (ETAP) included.

ETAP Electrical Transfer Access Prep

Cutout prep for the AMS and EL modifications. This allows for easy, one-person access to wiring between the hinge and door

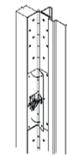

Security Fasteners

Specify Torx or Torx-Pin security fasteners in lieu of standard fasteners
 Contact factory for compatible models



CTP Current Transfer Prep

Centerline of hinge is standard location
 Hinge leaf cutout to accommodate Markar's EPT Electric Power Transfer or other manufacturers' power transfer units
 Please provide center line location (from top of hinge to centerline of prep) and handing for all prep locations - see CTP Form on Page 79
 Order form required; available online.

EPT Electric Power Transfer Units

EL-EPT	Stamped steel, for up to 105° opening
EL-EPTL	Stamped steel, long for 180° opening
EL-EPT-SC	Stamped steel, for swing clear hinges
EL-CEPTX32D	Cast Stainless Steel, satin
EL-CEPTX10B	Cast Stainless Steel, oil rubbed bronze

12-Wire with ElectroLynx® connectors standard on all power transfer units
 CTP prep is additional charge
 Note: Ordering EPT unit does not constitute CTP prep on hinge
 Order form required, available online.

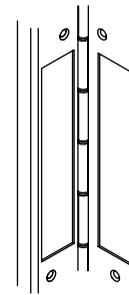

AMS Adjustable Monitoring Switch

Rigid welded assembly gives you the ability to adjust your monitoring switch to work with all applications 300 and 3500 Series
 Rating: 30v AC/DC .25 amps MAX
 We recommend an Electrical Transfer Access Prep (ETAP) with this modification.

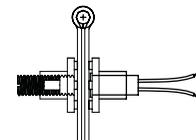

Experience a safer
 and more open world

800-824-3018 | www.pemko.com
 Check the web site for the up-to-date catalog

Copyright © 2015-2024, ASSA ABLOY Accessories and Door Controls Group, Inc., an ASSA ABLOY Group company. All rights reserved. Reproduction in whole or in part without the express written permission of ASSA ABLOY Accessories and Door Controls Group, Inc. is prohibited.

MARKAR 3500 SERIES STAINLESS STEEL PIN & BARREL CONTINUOUS HINGES

Short Form Architectural Specification:

Continuous hinges shall be full height piano-type hinge providing full height door support.

- Supports weights up to 900 lbs. 4'0" maximum door width
- Material to be 12 gauge (.105) Stainless Steel
- .187" diameter Stainless Steel pin (rod)
- Each knuckle 2", including nylon bearing at each separation for a quiet, smooth, self-lubricating operation
- Finish: US32D Satin Stainless Steel (630)
Optional Finish: US32 Bright Stainless Steel (629), Scratch-Resistant Powder Coated Paint.
- All hinges shall be furnished with manufacturer's recommended hardware pack per specific model application
- Must be able to carry UL label for fire rated doors and frames up to 3 hours
- Hinges shall meet ANSI/BHMA Standard A 156.26 Grade 1
- Symmetrically templated hole pattern

Note: 25-Year Warranty on Continuous Pin & Barrel Hinges

Note: Fire label for doors and frames should be placed on the header and top rail of fire rated doors and frames

MARKAR FM3500 EDGE MOUNT SECURITY HINGE

Standard Features

Barrel Type Hinge

.187" diameter Stainless Steel pin (rod)
Medical bearings
Stainless Steel end pins

Material

Heavy-duty 12 gauge (.105") Stainless Steel

Finishes

US32D Satin Stainless Steel (630)

Hospital Tip

Standard

Standards

ANSI/BHMA Standard A156.26 Grade 1

Hole Pattern

Symmetrically templated

Mounting Hardware

Fasteners concealed when door is closed
Custom 12-24 x 7/16" S.S Phillips Flat Head Undercut Machine Screw

Capacity

Supports weights up to 900lbs. 4'0" maximum door width

Standard Sizes

6'8", 7'0", 7'2", 8'0", 10'0"

Handing

Handing not required on standard hinges. Specify handing when ordering a hinge with modification

Fire Rating

3 hours- hollow metal doors
90 minutes- hollow metal and composite
20 minutes- wood doors



Windstorm

Classified in accordance with UL10C for positive pressure
Fire-rated label
Evaluated in accordance with TAS 201-14, TAS 202-14, TAS 203-14, ASTM E330, ASTM E1886, ASTM E1996 and ANSI A250.13.

Optional Features

Finish

US32 Bright Stainless Steel (629)
Scratch-Resistant Powder Coated Paint

Hole Patterns

Plug weld hole pattern
Custom hole pattern

Fasteners

Tamper-proof security screws

Other Features

Custom lengths - specify in inches
Dutch door hinges - suffix "DDP"
Raised barrel - suffix "RB"
Welded End Pins
Security studs

Electrical Modifications

Adjustable Monitoring Switch - suffix "AMS"
Current Transfer Prep - suffix "CTP"
Electrical Transfer Access Prep - "ETAP"
ElectroLynx®
EL4 (4 wire), EL8 (8 wire), EL12 (12 wire)
PoE (9 wire)

This edge mount pin and barrel type hinge is fabricated with extra-heavy duty components for use on high traffic, high abuse doors. The hinge is specially designed and well suited for correctional facilities and other high security locations using up to 2 1/4" thick swing-type doors. Prison doors, gates, extremely tall doors and extra heavy doors are all good candidates for Markar's 3500 Security Hinge.

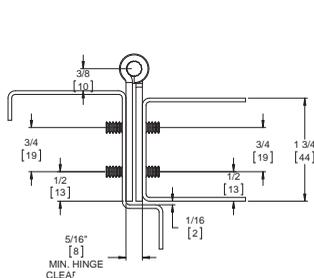

Door Closed

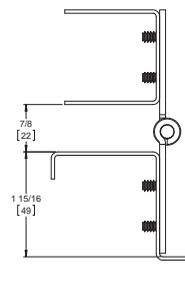

Door Open 180°

800-824-3018 | www.pemko.com

Check the web site for the up-to-date catalog

Copyright © 2015-2024, ASSA ABLOY Accessories and Door Controls Group, Inc., an ASSA ABLOY Group company. All rights reserved.
Reproduction in whole or in part without the express written permission of ASSA ABLOY Accessories and Door Controls Group, Inc. is prohibited.



Experience a safer
and more open world

MARKAR FS3501 1/8" INSET FULL SURFACE SECURITY HINGE

Standard Features

Barrel Type Hinge

.187" diameter Stainless Steel pin (rod)
Medical bearings
Stainless Steel end pins

Material

Heavy-duty 12 gauge (.105")
Stainless Steel

Finishes

US32D Satin Stainless Steel (630)
Hospital Tip Standard

Standards

ANSI/BHMA Standard A156.26
Grade 1

Mounting Hardware

Custom 12-24 x 7/16" S.S Phillips
Flat Head Undercut Machine
Screw

Capacity

Supports weights up to 900lbs.
4'0" maximum door width

Standard Sizes

6'8", 7'0", 7'2", 8'0", 10'0"

Hole Pattern

Symmetrically templated

Handing

Specify handing

Fire Rating

3 hours- hollow metal doors
90 minutes- hollow metal and composite
20 minutes- wood doors



Classified in accordance with UL10C
for positive pressure



Fire-rated label

Optional Features

Finish

US32 Bright Stainless Steel (629)
Scratch-Resistant Powder Coated Paint

Hole Patterns

Plug weld hole pattern
Custom hole pattern

Fasteners

Tamper-proof security screws

Other Features

Custom lengths – specify in inches
Dutch door hinges – suffix "DDP"
Welded End Pins

For 1/8" inset doors. This hinge allows for perfect alignment for the retrofitting of doors in correctional facilities and other high security locations using 2" thick swing-type doors. Prison doors, gates, extremely tall doors and extra heavy doors are all good candidates for Markar's 3501 Security Hinge.

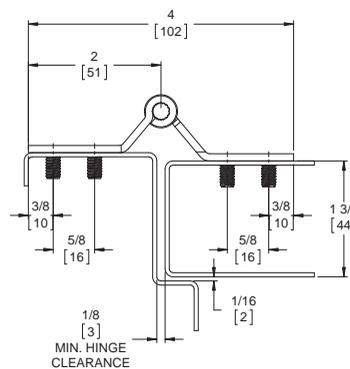

Door Closed

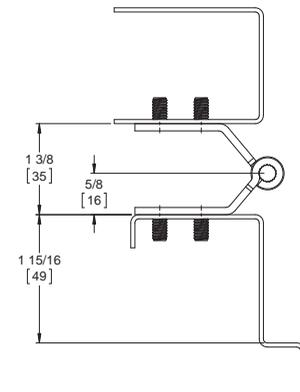

Door Open 180°



Experience a safer
and more open world

800-824-3018 | www.pemko.com
Check the web site for the up-to-date catalog

Copyright © 2015-2024, ASSA ABLOY Accessories and Door Controls Group, Inc., an ASSA ABLOY Group company. All rights reserved.
Reproduction in whole or in part without the express written permission of ASSA ABLOY Accessories and Door Controls Group, Inc. is prohibited.

MARKAR FS3502 FLUSH FULL SURFACE SECURITY HINGE

Standard Features

Barrel Type Hinge

.187" diameter Stainless Steel pin (rod)
Stainless Steel end pins
Medical bearings

Material

Heavy-duty 12 gauge (.105")
Stainless Steel

Finishes

US32D Satin Stainless Steel (630)
Hospital Tip Standard

Standards

ANSI/BHMA Standard A156.26 Grade 1

Mounting Hardware

Custom 12-24 x 7/16" S.S Phillips
Flat Head Undercut Machine
Screw

Capacity

Supports weights up to 900lbs.
4'0" maximum door width

Standard Sizes

6'8", 7'0", 7'2", 8'0", 10'0"

Hole Pattern

Symmetrically templated

Handing

Handing not required on standard
hinges Specify handing when
ordering a hinge with modification

Fire Rating

3 hours- hollow metal doors 90
minutes- hollow metal and composite
20 minutes- wood doors



Classified in accordance with
UL10C for positive pressure



Fire-rated label

Optional Features

Finish

US32 Bright Stainless Steel (629)
Scratch-Resistant Powder Coated Paint

Hole Patterns

Plug weld hole pattern
Custom hole pattern

Fasteners

Tamper-proof security screws

Other Features

Custom lengths - specify in inches
Dutch door hinges - suffix "DDP"
Welded End Pins

This surface-mounted pin and barrel type hinge is fabricated with extra-heavy duty components and designed for solving door sag problems on high traffic, high abuse doors. This hinge is well suited for correctional facilities and other high security locations using 2" thick swing-type doors. Prison doors, gates extremely tall doors and extra heavy doors are all good candidates for Markar's 3502 Security Hinge.

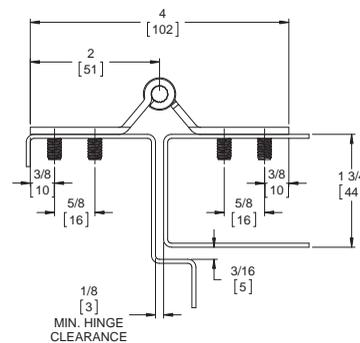

Door Closed

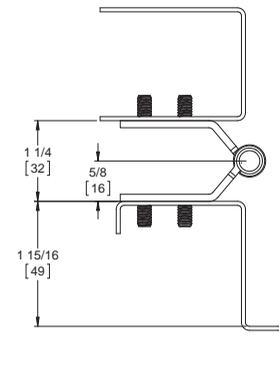

Door Open 180°

800-824-3018 | www.pemko.com

Check the web site for the up-to-date catalog

Copyright © 2015-2024, ASSA ABLOY Accessories and Door Controls Group, Inc., an ASSA ABLOY Group company. All rights reserved.
Reproduction in whole or in part without the express written permission of ASSA ABLOY Accessories and Door Controls Group, Inc. is prohibited.



Experience a safer
and more open world

MARKAR HG3505 ADJUSTABLE HINGE GUARD

Standard Features

Barrel Type Hinge

.187" diameter Stainless Steel pin (rod)
Medical bearings
Stainless Steel end pins

Material

Heavy-duty 12-gauge (.105") Stainless Steel hinge leaves
14 gauge Stainless Steel angle on door leaf

Finishes

US32D Satin Stainless Steel (630)
Hospital Tip Standard

Standards

ANSI/BHMA Standard A156.26
Grade 1

Mounting Hardware

Custom 12-24 x 7/16" S.S Phillips Flat Head Undercut Machine Screw

Capacity

Supports weights up to 900lbs.
4'0" maximum door width

Standard Sizes

6'8", 7'0", 7'2", 8'0", 10'0"

Hole Pattern

Symmetrically templated

Handing

Specify handing



Fire Rating

3 hours- hollow metal doors
90 minutes- hollow metal and composite 20 minutes- wood doors

Classified in accordance with UL10C for positive pressure

Fire-rated label

Optional Features

Finish

US32 Bright Stainless Steel (629)
Scratch-Resistant Powder Coated Paint

Mounting Hardware

Tamper-proof security screws
Adjust-A-Screw™ for correcting alignment problems up to 3/8"

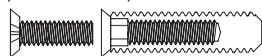

Other Features

Custom lengths – specify in inches
Custom hole pattern
Dutch door hinges – suffix "DDP"
Raised barrel - suffix "RB"
Welded end pins
Security studs

Electrical Modifications

Adjustable Monitoring Switch - suffix "AMS"
Current Transfer Prep - suffix "CTP"
Electronic Transfer Access Prep - suffix "ETAP"

ElectroLynx®

EL4 (4 wire), EL8 (8 wire), EL12 (12 wire)
PoE (9 wire)

The integral hinge guard protects the door from dings and gouges from carts and gurneys while providing clean lines and aesthetic appearance. Our HG products also have fire ratings up to and including 3 hours.

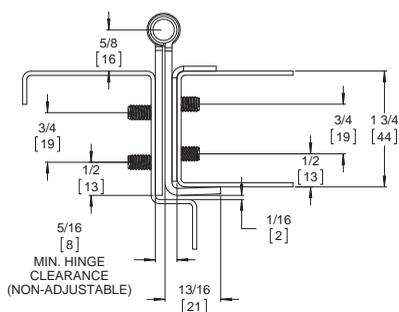

Door Closed

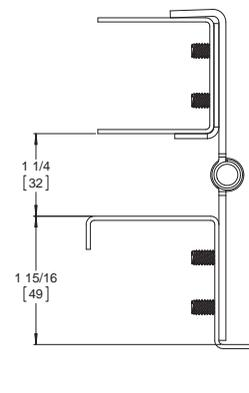

Door Open 180°



Experience a safer
and more open world

800-824-3018 | www.pemko.com
Check the web site for the up-to-date catalog

Copyright © 2015-2024, ASSA ABLOY Accessories and Door Controls Group, Inc., an ASSA ABLOY Group company. All rights reserved. Reproduction in whole or in part without the express written permission of ASSA ABLOY Accessories and Door Controls Group, Inc. is prohibited.

MARKAR 600 SERIES STAINLESS STEEL PIN & BARREL CONTINUOUS HINGES

Short Form Architectural Specification:

Continuous hinges shall be full height piano-type hinge providing full height door support.

- Supports weights up to 600 lbs. 4' 0" maximum door width
- Material to be 14 gauge 316 Stainless Steel
- .187" diameter Stainless Steel pin (rod)
- Exterior barrel diameter .438" (7/16")
- Each knuckle 2", including nylon bearing at each separation for a quiet, smooth, self-lubricating operation
- Finish: US32D Satin Stainless Steel (630)
Optional Finish: US32 Bright Stainless Steel (629), Scratch-Resistant Powder Coated Paint.
- All hinges shall be furnished with manufacturer's recommended hardware pack per specific model application
- Must be able to carry Warnock Hersey Int. or UL for fire rated doors and frames up to 3 hours
- Hinges shall meet ANSI/BHMA Standard A 156.26 Grade 1
- Symmetrically templated hole pattern

NOTE: 25-Year Warranty on Continuous Pin & Barrel Hinges

NOTE: Fire label for doors and frames should be placed on the header and top rail of fire rated doors and frames

MARKAR FM600 316 SS EDGE MOUNT HINGE

Standard Features

Barrel Type Hinge

.187" diameter Stainless Steel pin (rod)
Medical bearings
Stainless Steel end pins

Material

Heavy duty 14 gauge 316 stainless steel

Finishes

US32D Satin Stainless Steel (630)

Standards

ANSI/BHMA Standard A156.26 Grade 1

Hole Pattern

Symmetrically templated

Mounting Hardware

Fasteners concealed when door is closed
Custom 12-24 x 1 1/16" S.S Phillips Flat Head Undercut TEK Screws

Capacity

Supports weights up to 600 lbs. 4'0" maximum door width

Standard Sizes

6'8", 7'0", 7'2", 8'0", 10'0"

Handing

Handing not required on standard hinges. Specify handing when ordering a hinge with modification.

Rating

3 hours- hollow metal doors 90 minutes- hollow metal and composite core wood fire doors
20 minutes- wood doors



Classified in accordance with UL10C for positive pressure

Fire-rated label

Windstorm

Evaluated in accordance with TAS 201-14, TAS 202-14, TAS 203-14, ASTM E330, ASTM E1886, ASTM E1996 and ANSI A250.13

Optional Features

Finishes

Scratch-Resistant Powder Coated Paint

Fasteners

Tamper-proof security screws

Other Features

Custom lengths- specify in inches
Custom hole pattern
Dutch door hinges- suffix "DDP"
Hospital tips - suffix "HT"
Raised barrel - suffix "RB"
Welded end pins
Security studs.

Electrical Modifications

Adjustable Monitoring Switch - "AMS"
Current Transfer Prep - suffix "CTP"
Electrical Transfer Access Prep - suffix "ETAP"

ElectroLynx®

EL4 (4 wire), EL8 (8 wire), EL12 (12 wire)
PoE (9 wire)

This superior corrosion resistant edge mounted pin & barrel hinge is used in high chloride, sodium and sulfurous acid environments. This hinge works well in marine type environments.

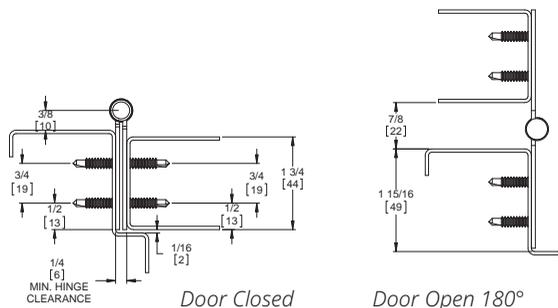

800-824-3018 | www.pemko.com

Check the web site for the up-to-date catalog

Copyright © 2015-2024, ASSA ABLOY Accessories and Door Controls Group, Inc., an ASSA ABLOY Group company. All rights reserved.
Reproduction in whole or in part without the express written permission of ASSA ABLOY Accessories and Door Controls Group, Inc. is prohibited.



Experience a safer and more open world

MARKAR 300 SERIES STAINLESS STEEL PIN & BARREL CONTINUOUS HINGES

Short Form Architectural Specification:

Continuous hinges shall be full height piano-type hinge providing full height door support.

- Supports weights up to 600 lbs. 4' 0" maximum door width
- Material to be 14 gauge Stainless Steel
- .187" diameter Stainless Steel pin (rod)
- Exterior barrel diameter .438" (7/16")
- Each knuckle 2", including nylon bearing at each separation for a quiet, smooth, self-lubricating operation
- Finish: US32D Satin Stainless Steel (630)
Optional Finish: US32 Bright Stainless Steel (629),
Scratch-Resistant Powder Coated Paint.
- All hinges shall be furnished with manufacturer's recommended hardware pack per specific model application
- Must be able to carry Warnock Hersey Int. or UL for fire rated doors and frames up to 3 hours
- Hinges shall meet ANSI/BHMA Standard A 156.26 Grade 1
- Symmetrically templated hole pattern

NOTE: 25-Year Warranty on Continuous Pin & Barrel Hinges

NOTE: Fire label for doors and frames should be placed on the header and top rail of fire rated doors and frames

MARKAR FM300 EDGE MOUNT HINGE

Standard Features

Barrel Type Hinge

.187" diameter Stainless Steel pin (rod)
Medical bearings
Stainless Steel end pins

Material

Heavy-duty 14 gauge Stainless Steel

Finishes

US32D Satin Stainless Steel (630)

Standards

ANSI/BHMA Standard A156.26 Grade 1

Hole Pattern

Symmetrically templated

Mounting Hardware

Fasteners concealed when door is closed
Custom 12-24 x 1 1/16" S.S Phillips Flat Head Undercut TEK Screws

Capacity

Supports weights up to 600 lbs.
4'0" maximum door width

Standard Sizes

6'8", 7'0", 7'2", 8'0", 10'0"

Handing

Handing not required on standard hinges. Specify handing when ordering a hinge with modification.

Rating

3 hours- hollow metal doors 90 minutes- hollow metal and composite core wood fire doors

20 minutes- wood doors

 Classified in accordance with UL10C for positive pressure

 Fire-rated label

Windstorm

Evaluated in accordance with TAS 201-94, TAS 202-94, TAS 203-94, ASTM E330, ASTM E1886, ASTM E1996 and ANSI A250.13

Optional Features

Finishes

Scratch-Resistant Powder Coated Paint

Fasteners

Tamper-proof security screws

Other Features

Custom lengths- specify in inches
Custom hole pattern
Dutch door hinges- suffix "DDP"
Hospital tips - suffix "HT"
Raised barrel - suffix "RB"
Welded end pins
Security studs.

Electrical Modifications

Adjustable Monitoring Switch - "AMS"
Current Transfer Prep - suffix "CTP"
Electrical Transfer Access Prep - suffix "ETAP"
ElectroLynx®
EL4 (4 wire), EL8 (8 wire), EL12 (12 wire)
PoE (9 wire)

This edge-mounted pin & barrel hinge is used on many of today's high traffic, high abuse doors. The hinge works well in locations that would normally call out for anchor hinges, pivot reinforcement hinges or thrust pivot unit and hinge sets. This hinge saves on special door and frame preparation charges and makes the installer's job easier. It can be used on both fire labeled and non-labeled openings.

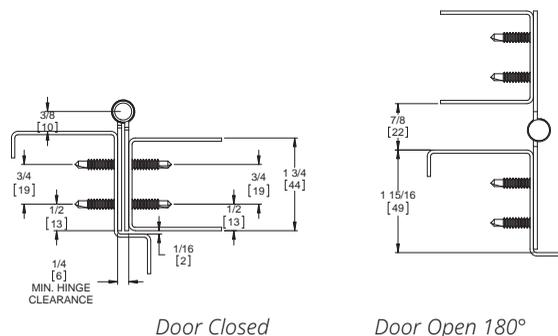

Experience a safer and more open world

800-824-3018 | www.pemko.com
Check the web site for the up-to-date catalog

Copyright © 2015-2024, ASSA ABLOY Accessories and Door Controls Group, Inc., an ASSA ABLOY Group company. All rights reserved. Reproduction in whole or in part without the express written permission of ASSA ABLOY Accessories and Door Controls Group, Inc. is prohibited.

MARKAR FM300WT WIDE THROW EDGE MOUNT HINGES

Standard Features

Barrel Type Hinge

.187" diameter Stainless Steel pin (rod)
Medical bearings
Stainless Steel end pins

Material

Heavy-duty 14 gauge Stainless Steel
Heavy-duty 12 gauge support angles, where applicable

Finishes

US32D Satin Stainless Steel (630)

Standards

ANSI/BHMA Standard A156.26 Grade 1

Mounting Hardware

Custom 12-24 x 1 1/16" S.S Phillips
Flat Head Undercut TEK Screws

Capacity

Weight: Consult factory
4'0" maximum door width

Standard Sizes

6'8", 7'0", 7'2", 8'0", 10'0"

Hole Pattern

Symmetrically templated

Handing

Handing not required on standard hinges. Specify handing when ordering a hinge with modification

Fire Rating

3 hours- hollow metal doors
90 minutes- hollow metal and composite core wood fire doors
20 minutes- wood doors



Classified in accordance with UL10C for positive pressure



Fire-rated label

Optional Features

Finishes

Scratch-Resistant Powder Coated Paint

Fasteners

Tamper-proof security screws

Other Features

Custom lengths- specify in inches

Custom hole pattern

Dutch door hinges- suffix "DDP"

Hospital tips - suffix "HT"

Welded end pins

Security studs

Electrical Modifications

Adjustable Monitoring Switch - suffix "AMS"

Current Transfer Prep - suffix "CTP"

Electrical Transfer Access Prep - suffix "ETAP"

ElectroLynx®

EL4 (4 wire), EL8 (8 wire), EL12 (12 wire)

- Available for WT10
- Available only with ETAP for all other WT models; extended lead times apply

This edge-mounted pin & barrel hinge is used on many of today's high traffic, high abuse doors. The hinge works well in locations that would normally call out for anchor hinges, pivot reinforcement hinges or thrust pivot unit and hinge sets. This hinge saves on special door and frame preparation charges and makes the installer's job easier. It can be used on both fire labeled and non-labeled openings.

FM300WT10

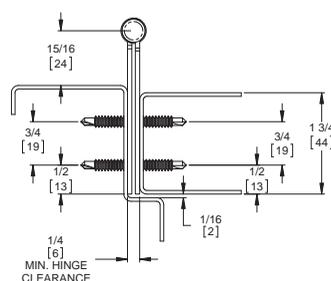

Door Closed

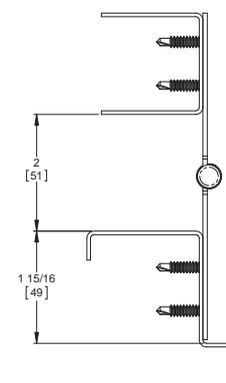

Door Open 180°

More profiles on next page

MARKAR FM300WT WIDE THROW EDGE MOUNT HINGES (Cont.)

FM300WT20

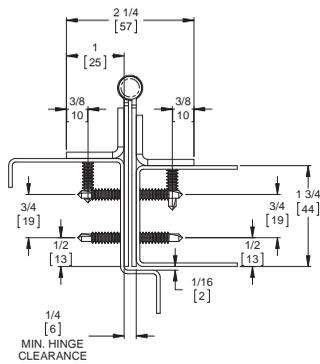

Door Closed

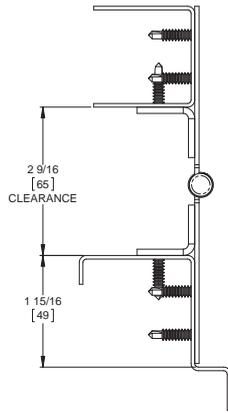

Door Open 180°

FM300WT30

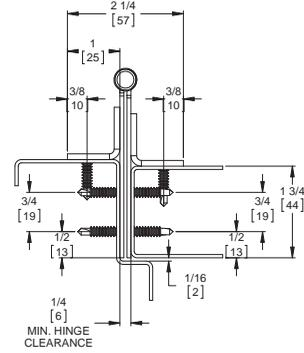

Door Closed

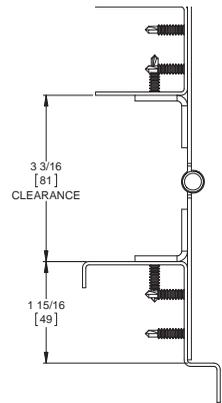

Door Open 180°

FM300WT40

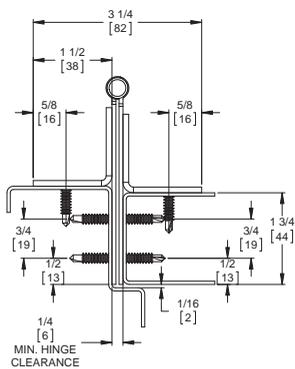

Door Closed

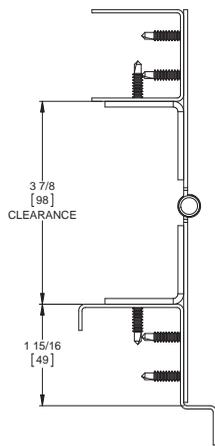

Door Open 180°

FM300WT50

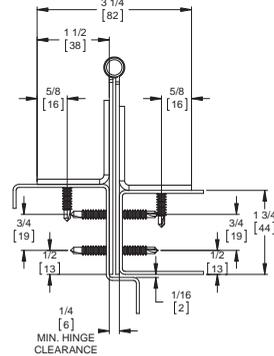

Door Closed

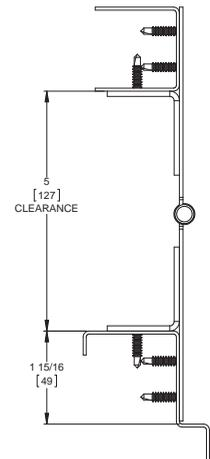

Door Open 180°



Experience a safer and more open world

800-824-3018 | www.pemko.com
Check the web site for the up-to-date catalog

Copyright © 2015-2024, ASSA ABLOY Accessories and Door Controls Group, Inc., an ASSA ABLOY Group company. All rights reserved. Reproduction in whole or in part without the express written permission of ASSA ABLOY Accessories and Door Controls Group, Inc. is prohibited.

MARKAR FS301 1/8" INSET FULL SURFACE HINGE

Standard Features

Barrel Type Hinge

.187" diameter Stainless Steel pin (rod)
Medical bearings
Stainless Steel end pins

Material

Heavy-duty 14 gauge Stainless Steel
Cover - extruded aluminum

Finishes

US32D Satin Stainless Steel (630)
Cover - brushed aluminum

Standards

ANSI/BHMA Standard A156.26 Grade 1

Mounting Hardware

Fasteners concealed underneath
aluminum cover
1/4-14 x 3/4" Security TORX
TEK Screws

Capacity

Supports weights up to 600 lbs.
4'0" maximum door width

Standard Sizes

6'8", 7'0", 7'2", 8'0", 10'0"

Handing

Not required for standard 7'0",
8'0" or 10'0". Handing required for
6'8" and 7'2" and for most optional
features listed

Fire Rating

3 hours- hollow metal doors
90 minutes- hollow metal and composite
core wood fire doors
20 minutes- wood doors



Classified in accordance with
UL10C for positive pressure
Fire-rated label

Optional Features

Finishes

US32 Bright Stainless Steel (629)
Scratch-Resistant Powder Coated Paint

Fasteners

1 5/8" S.S. sleeve bolts
Tamper-proof security screws

Other Features

Custom lengths- specify in inches
Custom hole pattern
Dutch door hinges - suffix "DDP"
Hospital tips - suffix "HT"
Lead lined covers with 4 lbs. lead
lining - suffix "LL"
Welded end pins

This surface-mounted pin & barrel continuous hinge can be used to repair or replace existing hinges on both fire labeled and non-labeled doors that have very tight clearances. The hinge has a built-in 1/8" offset to assist in weather seal and sound barrier areas.

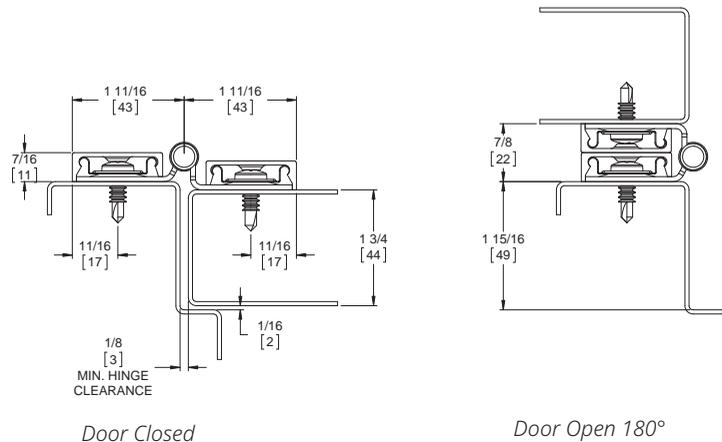

MARKAR FS302 FULL SURFACE FLUSH MOUNT

Standard Features

Barrel Type Hinge

.187" diameter Stainless Steel pin (rod)
Medical bearings
Stainless Steel end pins

Material

Heavy-duty 14 gauge Stainless Steel
Cover - extruded aluminum

Finishes

US32D Satin Stainless Steel (630)
Cover - brushed aluminum

Standards

ANSI/BHMA Standard A156.26 Grade 1

Mounting Hardware

Fasteners concealed underneath
aluminum cover
1/4" - 14 x 3/4" Security TORX
TEK Screws Capacity
Supports weights up to 600 lbs.
4'0" maximum door width

Standard Sizes

6'8", 7'0", 7'2", 8'0", 10'0"

Hole Pattern

Symmetrically templated

Handing

Handing not required on standard
hinges. Specify handing when
ordering a hinge with modification

Fire Rating

3 hours- hollow metal doors
90 minutes- hollow metal and
composite core wood fire doors
20 minutes- wood doors



Classified in accordance with
UL10C for positive pressure



Fire-rated label

Optional Features

Finishes

US32 Bright Stainless Steel (629)
Scratch-Resistant Powder Coated Paint

Fasteners

1 5/8" S.S. sleeve bolts
Tamper-proof security screws

Other Features

Custom lengths- specify in inches
Custom hole pattern
Dutch door hinges - suffix "DDP"
Hospital tips - suffix "HT"
Lead lined covers with 4 lbs. lead
lining - suffix "LL"
Welded end pins

This surface-mounted pin & barrel
continuous hinge can be used to
replace and repair existing hinges
on both fire labeled and non-labeled
doors. Designed for retrofit market.

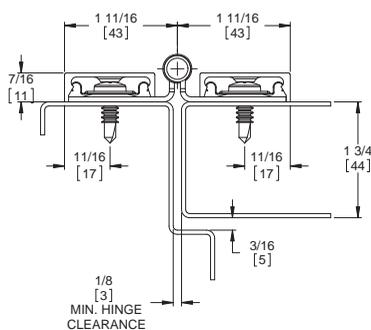

Door Closed

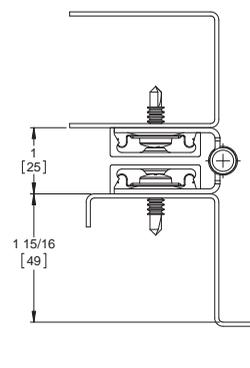

Door Open 180°



Experience a safer
and more open world

800-824-3018 | www.pemko.com
Check the web site for the up-to-date catalog

Copyright © 2015-2024, ASSA ABLOY Accessories and Door Controls Group, Inc., an ASSA ABLOY Group company. All rights reserved.
Reproduction in whole or in part without the express written permission of ASSA ABLOY Accessories and Door Controls Group, Inc. is prohibited.

MARKAR HS303 HALF SURFACE HINGE

Standard Features

Barrel Type Hinge

.187" diameter Stainless Steel pin (rod)
Medical bearings
Stainless Steel end pins

Material

Heavy-duty 14 gauge Stainless Steel
Cover - extruded aluminum

Finishes

US32D Satin Stainless Steel (630)
Cover - brushed aluminum

Standards

ANSI/BHMA Standard A156.26 Grade 1

Mounting Hardware

Fasteners concealed when door is closed
Custom 12-24 x 1¹¹/₁₆" S.S Phillips Flat Head Undercut TEK Screws & 1¹/₄-14 x 3³/₄" Security TORX TEK Screws

Capacity

Supports weights up to 600 lbs.
4'0" maximum door width

Sizes

6'8", 7'0", 7'2", 8'0", 10'0"

Hole Pattern

Symmetrically templated

Handing

Not required for standard 7'0", 8'0" or 10'0". Handing required for 6'8" and 7'0" and for most optional features listed

Fire Rating

3 hours- hollow metal doors
90 minutes- hollow metal and composite
20 minutes- wood doors



Classified in accordance with UL10C for positive pressure



Fire-rated label

Optional Features

Finish

US32 Bright Stainless Steel (629)
Scratch-Resistant Powder Coated Paint

Fasteners

1⁵/₈" S.S. sleeve bolts
Tamper-proof security screws

Other Features

Custom lengths - specify in inches
Custom hole pattern
Dutch door hinges - suffix "DDP"
Hospital tips - suffix "HT"
Raised barrel - suffix "RB"
Welded end pins
Lead lined cover with 4 lbs. lead lining - suffix "LL"

Electrical Modifications

Current Transfer Prep (frame leaf only) - suffix "CTP"

This half-surface pin & barrel continuous hinge can be used to repair or replace existing hinges on both fire labeled openings. The hinge fits into the gap left after standard butt hinges are removed. It can assist in reversing the handing of a door, or to reverse the swing of a door hung in an evenly-rabbetted frame. (Please consult factory for instructions for unevenly-rabbetted frames.)

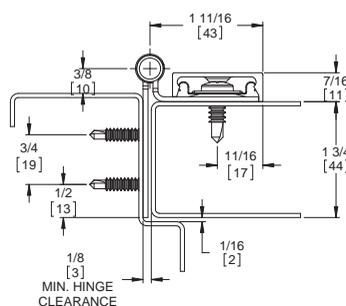

Door Closed

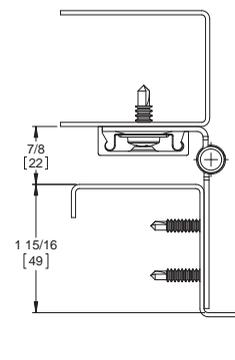

Door Open 180°

MARKAR HM304 HALF MORTISE HINGE

Standard Features

Barrel Type Hinge

.187" diameter Stainless Steel pin (rod)
 Medical bearings
 Stainless Steel end pins

Material

Heavy-duty 14 gauge Stainless Steel
 Cover - extruded aluminum

Finishes

US32D Satin Stainless Steel (630)
 Cover - brushed aluminum

Standards

ANSI/BHMA Standard A156.26 Grade 1

Mounting Hardware

Fasteners concealed when door is closed
 Custom 12-24 x 1¹/₁₆" S.S Phillips Flat Head Undercut TEK Screws & 1¹/₄-14 x 3³/₄" Security TORX TEK Screws

Capacity

Supports weights up to 600 lbs.
 4'0" maximum door width
 Standard Sizes

6'8", 7'0", 7'2", 8'0", 10'0"

Hole Pattern

Symmetrically templated

Handing

Not required for standard 7'0", 8'0" or 10'0". Handing required for 6'8" and 7'2" and for most optional features listed

Fire Rating

3 hours- hollow metal doors
 90 minutes- hollow metal and composite
 20 minutes- wood doors



Classified in accordance with UL10C for positive pressure

Fire-rated label

Optional Features

Finishes

US32 Bright Stainless Steel (629)
 Scratch-Resistant Powder Coated Paint

Fasteners

Tamper-proof security screws

Other Features

Custom lengths- specify in inches
 Custom hole pattern
 Dutch door hinges- suffix "DDP"
 Hospital tips - suffix "HT"
 Raised barrel - suffix "RB"
 Welded end pins

Electrical Modifications

Current Transfer Prep (door leaf only)
 - suffix "CTP"

This pin & barrel type hinge is used on wooden doors to hide splits, chips and dents from traffic abuse. The surface mounted frame leaf allows for easy retrofit installation.

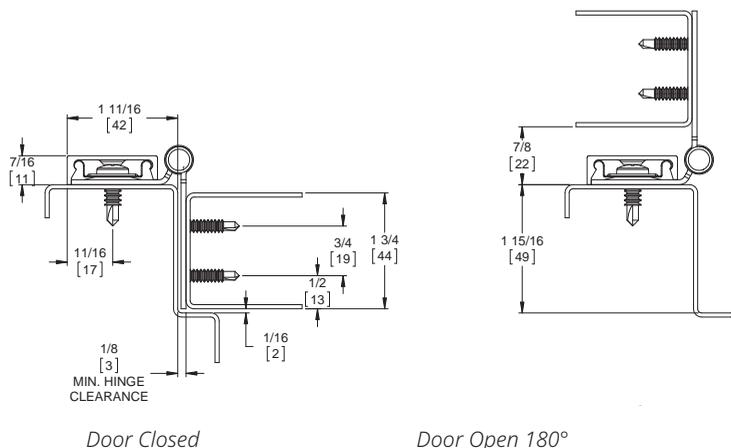

Experience a safer
 and more open world

800-824-3018 | www.pemko.com
 Check the web site for the up-to-date catalog

Copyright © 2015-2024, ASSA ABLOY Accessories and Door Controls Group, Inc., an ASSA ABLOY Group company. All rights reserved. Reproduction in whole or in part without the express written permission of ASSA ABLOY Accessories and Door Controls Group, Inc. is prohibited.

MARKAR HG305 ADJUSTABLE HINGE GUARD

Standard Features

Barrel Type Hinge

.187" diameter Stainless Steel pin (rod)
 Medical bearings
 Stainless Steel end pins

Material

Heavy-duty 14 gauge Stainless Steel

Finishes

US32D Satin Stainless Steel (630)

Standards

ANSI/BHMA Standard A156.26 Grade 1

Mounting Hardware

Fasteners concealed when door is closed
 Custom 12-24 x 1¹/₁₆" S.S Phillips Flat Head Undercut TEK Screws

Capacity

Supports weights up to 600 lbs.
 4'0" maximum door width

Standard Sizes

6'8", 7'0", 7'2", 8'0", 10'0"

Hole Pattern

Symmetrically templated

Handing

Not required for standard 7'0", 8'0" or 10'0". Handing required for 6'8" and 7'2" and for most optional features listed

Fire Rating

3 hours- hollow metal doors
 90 minutes- hollow metal and composite
 20 minutes- wood doors



Classified in accordance with UL10C for positive pressure



Fire-rated label

Windstorm

Products is constructed in accordance with Guidelines FEMA 320 & FEMA 361.

Optional Features

Finish

US32 Bright Stainless Steel (629)
 Scratch-Resistant Powder Coated Paint

Fasteners

Adjust-A-Screw™ for correcting frame fit problems up to 3/8"

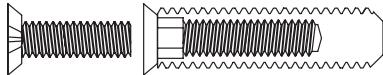

Other Features

Custom lengths- specify in inches
 Custom hole pattern
 Dutch door hinges- suffix "DDP"
 Hospital tips – suffix "HT"
 Raised barrel – suffix "RB"
 Welded end pins
 Security studs

Electrical Modifications

Adjustable Monitoring Switch - suffix "AMS"
 Current Transfer Prep - suffix "CTP"
 Electrical Transfer Access Prep - suffix "ETAP"
ElectroLynx®
 EL4 (4 wire), EL8 (8 wire), EL12 (12 wire)
 PoE (9 wire)

The integral hinge guard protects the door from dings and gouges from carts and gurneys while providing clean lines and aesthetic appearance. Our HG products also have fire ratings up to and including 3 hours. Not only that, but the wrap-around edge guard protects the door from unsightly dents and gouges and will deflect objects, preventing further damage.

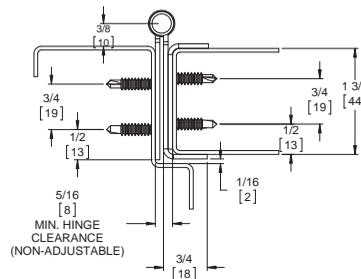

Door Closed

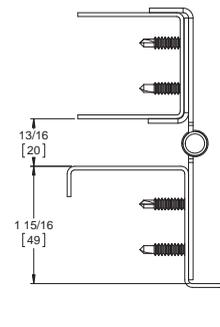

Door Open 180°

800-824-3018 | www.pemko.com

Check the web site for the up-to-date catalog

Copyright © 2015-2024, ASSA ABLOY Accessories and Door Controls Group, Inc., an ASSA ABLOY Group company. All rights reserved. Reproduction in whole or in part without the express written permission of ASSA ABLOY Accessories and Door Controls Group, Inc. is prohibited.



Experience a safer and more open world

MARKAR FS/SC309 FULL SURFACE SWING CLEAR HINGE

Standard Features

Barrel Type Hinge

.187" diameter Stainless Steel pin (rod)
 Medical bearings
 Stainless Steel end pins

Material

Heavy-duty 14 gauge Stainless Steel
 Cover - extruded aluminum

Finishes

US32D Satin Stainless Steel (630)
 Cover - brushed aluminum

Standards

ANSI/BHMA Standard A156.26 Grade 1

Mounting Hardware

Fasteners concealed when door is closed
 Custom 12-24 x 1¹/₁₆" S.S Phillips Flat Head Undercut TEK Screws & 1¹/₄-14 x 3³/₄" Security TORX TEK Screws

Capacity

Supports weights up to 600 lbs.
 4'0" maximum door width

Standard Sizes

6'8", 7'0", 7'2", 8'0", 10'0"

Hole Pattern

Symmetrically templated

Handing

Not required for standard 7'0", 8'0" or 10'0". Specify handing for 6'8" and 7'2" and for most optional features

Fire Rating

3 hours- hollow metal doors
 90 minutes- hollow metal and composite
 20 minutes- wood doors



Classified in accordance with UL10C for positive pressure



Fire-rated label

Optional Features

Finish

US32 Bright Stainless Steel (629)
 Scratch-Resistant Powder Coated
 Paint

Fasteners

Tamper-proof security screws

Other Features

Custom lengths- specify in inches
 Custom hole pattern
 1⁵/₈" S.S. aluminum sleeve bolts
 Dutch door hinges - suffix "DDP"
 Hospital tips - suffix "HT"
 Lead lined cover with 4 lbs. lead lining - suffix "LL"
 Welded End Pins

This hinge is used to ensure that a door opened to a 90-degree angle is removed from the opening. This hinge will mount on a 1³/₄" face, and is especially useful for ADA upgrade work.

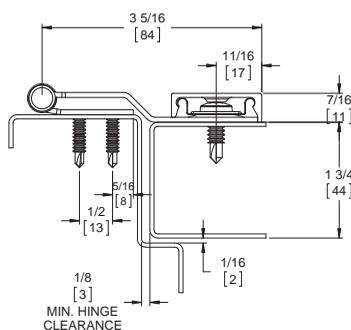

Door Closed

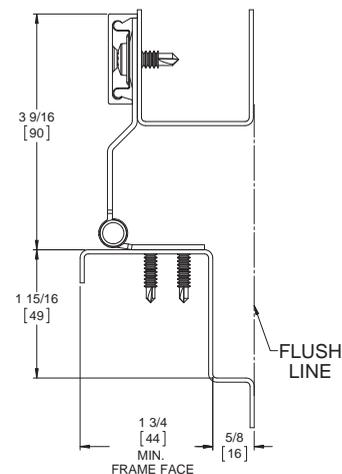

Door Open 90°



Experience a safer
 and more open world

MARKAR HG310 SWING CLEAR ADJUSTABLE HINGE GUARD

Standard Features

Barrel Type Hinge

.187" diameter Stainless Steel pin (rod)
Medical bearings
Stainless Steel end pins

Material

Heavy-duty 14 gauge Stainless Steel

Finishes

US32D Satin Stainless Steel (630)

Standards

ANSI/BHMA Standard A156.26 Grade 1

Mounting Hardware

Fasteners concealed when door is closed

Custom 12-24 x 1¹/₁₆" S.S Phillips Flat Head Undercut TEK Screws

Capacity

Supports weights up to 600 lbs.
4'0" maximum door width

Standard Sizes

6'8", 7'0", 7'2", 8'0", 10'0"

Hole Pattern

Symmetrically templated

Handing

Not required for standard 7'0", 8'0" or 10'0". Specify handing for 6'8" and 7'2" and for most optional features

Door Edge

Square hinge edge
Recommend Adjust-A-Screw for beveled hinge edge

Fire Rating

3 hours- hollow metal doors
90 minutes- hollow metal and composite core wood fire doors
20 minutes- wood doors



Classified in accordance with UL10C for positive pressure



Fire-rated label

Optional Features

Finishes

US32 Bright Stainless Steel (629)
Scratch-Resistant Powder Coated Paint

Fasteners

Tamper-proof security screws
Adjust-A-Screws™ for correcting frame fit problems up to 3/8"

Other Features

Custom lengths- specify in inches
Custom hole pattern
Dutch door hinges - suffix "DDP"
Hospital tips - suffix "HT"
Welded End Pins

Electrical Modifications

Current Transfer Prep (door leaf only) - suffix "CTP"
(EL-EPT-SC Power Transfer Recommended)

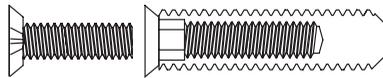

The ADA-compliant hinge is used on operating room doors to swing the door out of the opening when moving equipment in and out. The hinge guard also protects the door in the open position.

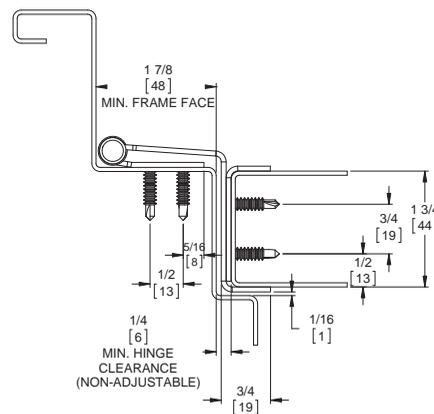

Door Closed

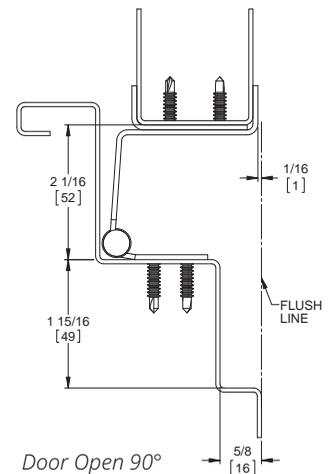

Door Open 90°

800-824-3018 | www.pemko.com

Check the web site for the up-to-date catalog

Copyright © 2015-2024, ASSA ABLOY Accessories and Door Controls Group, Inc., an ASSA ABLOY Group company. All rights reserved.
Reproduction in whole or in part without the express written permission of ASSA ABLOY Accessories and Door Controls Group, Inc. is prohibited.



Experience a safer and more open world

MARKAR HG311 SWING CLEAR HINGE GUARD

Standard Features

Barrel Type Hinge

.187" diameter Stainless Steel pin (rod)
Medical bearings
Stainless Steel end pins

Material

Heavy-duty 14 gauge Stainless Steel

Finishes

US32D Satin Stainless Steel (630)

Standards

ANSI/BHMA Standard A156.26 Grade 1

Mounting Hardware

Fasteners concealed when door is closed

Custom 12-24 x 1¹/₁₆" S.S Phillips Flat Head Undercut TEK Screws

Capacity

Supports weights up to 600 lbs.
4'0" maximum door width

Standard Sizes

6'8", 7'0", 7'2", 8'0", 10'0"

Hole Pattern

Symmetrically templated

Handing

Not required for standard 7'0", 8'0" or 10'0". Specify handing for 6'8" and 7'2" and for most optional features

Door Edge

Square hinge edge
For beveled hinge edge use HG310

Fire Rating

3 hours- hollow metal doors
90 minutes- hollow metal and composite core wood fire doors
20 minutes- wood doors



Classified in accordance with UL10C for positive pressure



Fire-rated label

Optional Features

Finishes

US32 Bright Stainless Steel (629)
Scratch-Resistant Powder Coated
Paint

Fasteners

Tamper-proof security screws

Other Features

Custom lengths- specify in inches
Custom hole pattern
Dutch door hinges - suffix "DDP"
Hospital tips - suffix "HT"
Welded End Pins

Electrical Modifications

Current Transfer Prep (door leaf only) - suffix "CTP"
(EL-EPT-SC Power Transfer Recommended)

This surface applied swing clear version allows doors to meet ADA requirements. The single wrap protects door edges from cart damage.

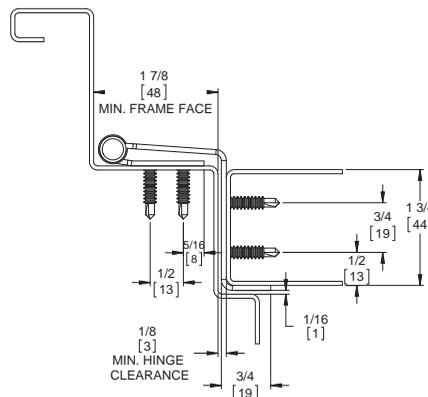

Door Closed

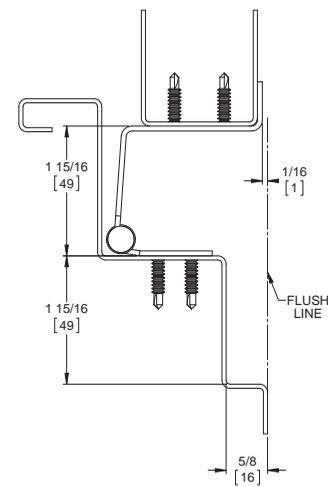

Door Open 90°



Experience a safer and more open world

800-824-3018 | www.pemko.com
Check the web site for the up-to-date catalog

Copyright © 2015-2024, ASSA ABLOY Accessories and Door Controls Group, Inc., an ASSA ABLOY Group company. All rights reserved. Reproduction in whole or in part without the express written permission of ASSA ABLOY Accessories and Door Controls Group, Inc. is prohibited.

MARKAR HG315 EDGE MOUNT HINGE GUARD

Standard Features

Barrel Type Hinge

.187" diameter Stainless Steel pin (rod)
 Medical bearings
 Stainless Steel end pins

Material

Heavy-duty 14 gauge Stainless Steel

Finishes

US32D Satin Stainless Steel (630)

Standards

ANSI/BHMA Standard A156.26 Grade 1

Mounting Hardware

Fasteners concealed when door is closed

Custom 12-24 x 1¹/₁₆" S.S Phillips Flat Head Undercut TEK Screws

Capacity

Supports weights up to 600 lbs.
 4'0" maximum door width

Standard Sizes

6'8", 7'0", 7'2", 8'0", 10'0"

Hole Pattern

Symmetrically templated

Handing

Not required for standard 7'0", 8'0" or 10'0". Specify handing for 6'8" and 7'2" and for most optional features

Fire Rating

3 hours- hollow metal doors
 90 minutes- hollow metal and composite core wood fire doors
 20 minutes- wood doors



Classified in accordance with UL10C for positive pressure



Fire-rated label

Optional Features

Finishes

US32 Bright Stainless Steel (629)
 Scratch-Resistant Powder Coated Paint

Fasteners

Tamper-proof security screws

Other Features

Custom lengths- specify in inches
 Custom hole pattern
 Dutch door hinges- suffix "DDP"
 Hospital tips - suffix "HT"
 Raised barrel - suffix "RB"
 Welded end pins
 Security studs

Electrical Modifications

Adjustable Monitoring Switch - suffix "AMS"
 Current Transfer Prep - suffix "CTP"
 Electrical Transfer Access Prep - suffix "ETAP"

ElectroLynx®

EL4 (4 wire), EL8 (8 wire), EL12 (12 wire)
 PoE (9 wire)

Featuring our unique edge guard, this economical hinge prevents objects from being placed between the door and frame as well as protects the door's edge while supporting the door's weight along the entire length of the jamb.

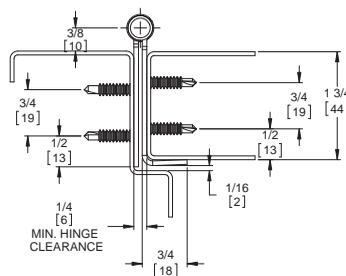

Door Closed

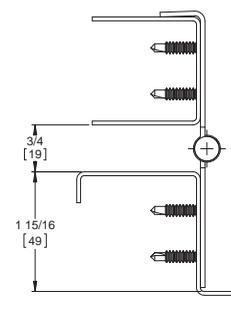

Door Open 180°

800-824-3018 | www.pemko.com

Check the web site for the up-to-date catalog

Copyright © 2015-2024, ASSA ABLOY Accessories and Door Controls Group, Inc., an ASSA ABLOY Group company. All rights reserved.
 Reproduction in whole or in part without the express written permission of ASSA ABLOY Accessories and Door Controls Group, Inc. is prohibited.



Experience a safer
 and more open world

MARKAR HG323 EDGE MOUNT HINGE GUARD

Standard Features

Barrel Type Hinge

.187" diameter Stainless Steel pin (rod)
Medical bearings
Stainless Steel end pins

Material

Heavy-duty 14 gauge Stainless Steel

Finishes

US32D Satin Stainless Steel (630)
Standards
ANSI/BHMA Standard A156.26
Grade 1

Mounting Hardware

Fasteners concealed when door is closed
Custom 12-24 x 1¹/₁₆" S.S Phillips Flat Head Undercut TEK Screws & 1/4"-20 x 1⁵/₈" Thru Bolt Stainless Steel

Capacity

Supports weights up to 600 lbs.
4'0" maximum door width

Standard Sizes

6'8", 7'0", 7'2", 8'0", 10'0"

Hole Pattern

Symmetrically templated

Handing

Not required for standard 7'0", 8'0" or 10'0". Specify handing for 6'8" and 7'2" and for most optional features

Fire Rating

3 hours- hollow metal doors
90 minutes- hollow metal and composite core wood fire doors
20 minutes- wood doors



Classified in accordance with UL10C for positive pressure



Fire-rated label

Optional Features

Finishes

US32 Bright Stainless Steel (629)
Scratch-Resistant Powder Coated Paint

Fasteners

Tamper-proof security screws

Other Features

Custom lengths- specify in inches
Custom hole pattern
Dutch door hinges - suffix "DDP"
Hospital tips - suffix "HT"
Raised barrel - suffix "RB"
Special sheared leaf

Electrical Modifications

Adjustable Monitoring Switch - suffix "AMS"
Current Transfer Prep - suffix "CTP"
Electrical Transfer Access Prep - suffix "ETAP"

ElectroLynx®

EL4 (4 wire), EL8 (8 wire), EL12 (12 wire)
PoE (9 wire)

This extended wrap model allows you to sandwich the door between two leaves of Stainless Steel and through bolt them together. It is ideal where doors have split and you want to save them.

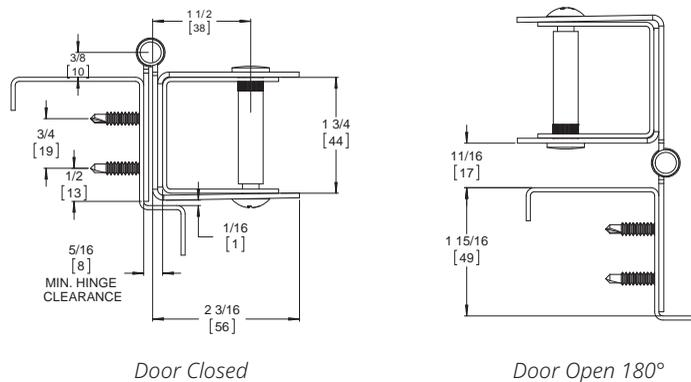

Experience a safer
and more open world

800-824-3018 | www.pemko.com
Check the web site for the up-to-date catalog

Copyright © 2015-2024, ASSA ABLOY Accessories and Door Controls Group, Inc., an ASSA ABLOY Group company. All rights reserved. Reproduction in whole or in part without the express written permission of ASSA ABLOY Accessories and Door Controls Group, Inc. is prohibited.

MARKAR HG326 SWING CLEAR ADJUSTABLE HINGE GUARD

Standard Features

Barrel Type Hinge

.187" diameter Stainless Steel pin (rod)
 Medical bearings
 Stainless Steel end pins

Material

Heavy-duty 14 gauge Stainless Steel
 Finishes
 US32D Satin Stainless Steel (630)

Standards

ANSI/BHMA Standard A156.26
 Grade 1

Mounting Hardware

Custom 12-24 x 1¹/₁₆" S.S Phillips Flat Head Undercut TEK Screws

Capacity

Supports weights up to 600 lbs.
 4'0" maximum door width

Standard Sizes

6'8", 7'0", 7'2", 8'0", 10'0"

Hole Pattern

Symmetrically templated

Door Edge

Square hinge edge
 Recommend Adjust-A-Screw for beveled hinge edge

Handing

Not required for standard 7'0", 8'0" or 10'0". Specify handing for 6'8" and 7'2" and for most optional features

Fire Rating

3 hours- hollow metal doors
 90 minutes- hollow metal and composite core wood fire doors
 20 minutes- wood doors



Classified in accordance with UL10C for positive pressure



Fire-rated label

Optional Features

Finishes

US32 Bright Stainless Steel (629)
 Scratch-Resistant Powder Coated Paint

Other Features

Custom lengths- specify in inches
 Custom hole pattern
 Dutch door hinges- suffix "DDP"
 Hospital tips - suffix "HT"
 Welded end pins

Fasteners

Tamper-proof security screws
 Adjust-A-Screw™ for correcting frame fit problems up to 3/8"

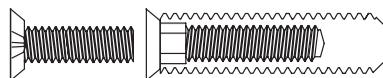

Electrical Modifications

Current Transfer Prep - suffix "CTP"
 (EL-EPT-SC Power Transfer Recommended)

The incorporated edge guard protects the door from unsightly dents and gouges while also protecting the hinge from vandalism.

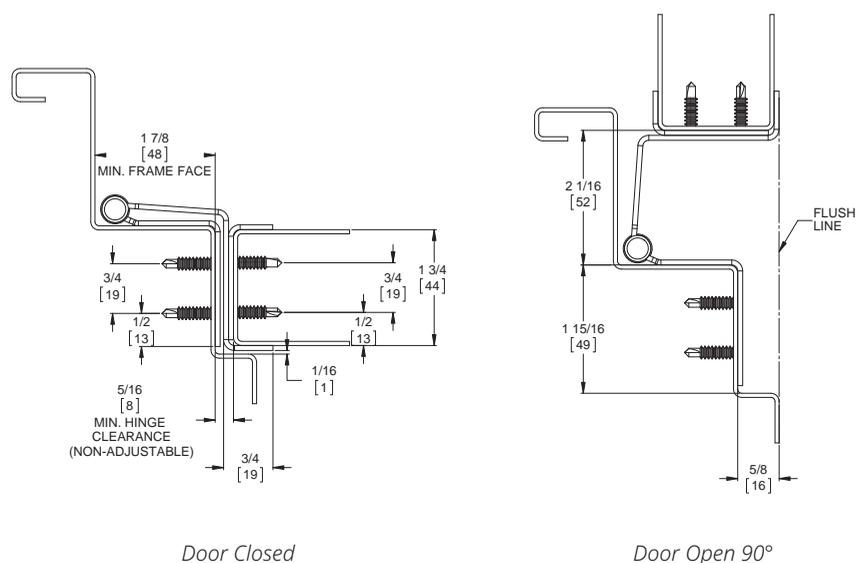

800-824-3018 | www.pemko.com

Check the web site for the up-to-date catalog

Copyright © 2015-2024, ASSA ABLOY Accessories and Door Controls Group, Inc., an ASSA ABLOY Group company. All rights reserved.
 Reproduction in whole or in part without the express written permission of ASSA ABLOY Accessories and Door Controls Group, Inc. is prohibited.



Experience a safer
 and more open world

MARKAR HG329 SWING CLEAR HINGE GUARD FOR SQUARE EDGE DOOR

Standard Features

Barrel Type Hinge

.187" diameter Stainless Steel pin (rod)

Medical bearings

Stainless Steel end pins

Material

Heavy-duty 14 gauge Stainless Steel

Finishes

US32D Satin Stainless Steel (630)

Standards

ANSI/BHMA Standard A156.26 Grade 1

Mounting Hardware

Fasteners concealed when door is closed

Custom 12-24 x 1¹/₁₆" S.S Phillips Flat

Head Undercut TEK Screws

Capacity

Supports weights up to 600 lbs.

4'0" maximum door width

Standard Sizes

6'8", 7'0", 7'2", 8'0", 10'0"

Door Edge

Square hinge edge

For beveled hinge edge use HG326

Hole Pattern

Symmetrically templated

Specify handing

Fire Rating

3 hours- hollow metal doors

90 minutes- hollow metal and

composite core wood fire doors

20 minutes- wood doors



Classified in accordance with UL10C for positive pressure



Fire-rated label

Optional Features

Finishes

US32 Bright Stainless Steel (629)

Scratch-Resistant Powder

Coated Paint

Other Features

Custom lengths- specify in inches

Custom hole pattern

Dutch door hinges- suffix "DDP"

Hospital tips - suffix "HT"

Welded end pins

Fasteners

Tamper-proof security screws

Electrical Modifications

Adjustable Monitoring Switch - suffix

"AMS" Current Transfer Prep - suffix "CTP"

(EL-EPT-SC Power Transfer

Recommended)

The incorporated edge guard protects the door from unsightly dents and gouges while also protecting the hinge from vandalism.

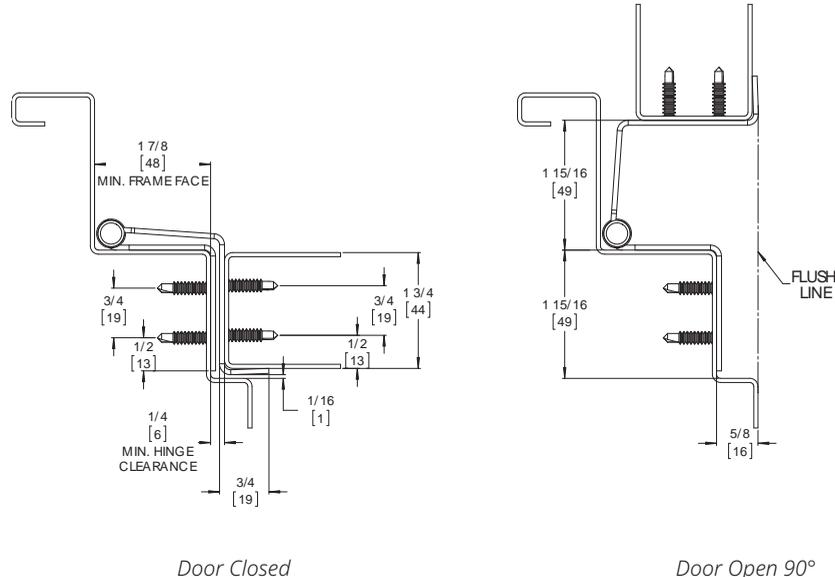

Experience a safer and more open world

800-824-3018 | www.pemko.com
Check the web site for the up-to-date catalog

Copyright © 2015-2024, ASSA ABLOY Accessories and Door Controls Group, Inc., an ASSA ABLOY Group company. All rights reserved. Reproduction in whole or in part without the express written permission of ASSA ABLOY Accessories and Door Controls Group, Inc. is prohibited.

MARKAR EG308 ADJUSTABLE EDGE GUARD

Standard Features

Material
Heavy-duty 16 gauge stainless steel

Finishes
US32D Satin Stainless Steel (630)

Mounting Hardware
Fasteners concealed when door is closed

Included fasteners are:
Custom 12-24 x 1 1/16" S.S Phillips Flat Head Undercut TEK Screws
Custom 12-24 x 1 1/2" S.S. Phillips Flat Head Particle Board Screws
Order form required, available

online.
Standard Sizes
6'8", 7'0", 7'2", 8'0", 10'0"
Door Edge
Specify square or beveled edge when ordering (beveled edge standard)

Fire Rating
3 hours- hollow metal doors
90 minutes- hollow metal and composite
20 minutes- wood doors



Fire-rated label

MAY NOT APPLY TO ALL WOOD DOORS. PLEASE CONSULT FACTORY FOR SPECIFIC WOOD DOOR APPLICATIONS.

Optional Features

Finish
US32 Bright Stainless Steel (629)
Scratch-Resistant Powder Coated Paint
Hardware Cutouts
(Edge Guard order form must be filled out)
Flush bolts
ASA strike
Deadlock strike and latch
86 edge
Hospital latch
161 cutout

Fasteners
Tamper-proof security screws
Adjust-A-Screw™ for correcting frame fit problems up to 3/8"

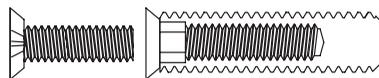

Other Features
Custom lengths - specify in inches
Staggered hole pattern for lead lined doors
Custom cutouts
Dutch door application - suffix "DDP"

This fire-labeled edge guard is used in conjunction with the HG305 Hinge/Guard for a balanced aesthetic look. It also provides protection for the leading edge of the door.

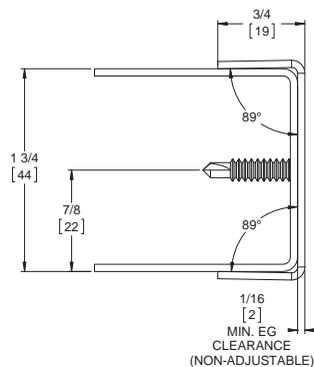

Square edge door

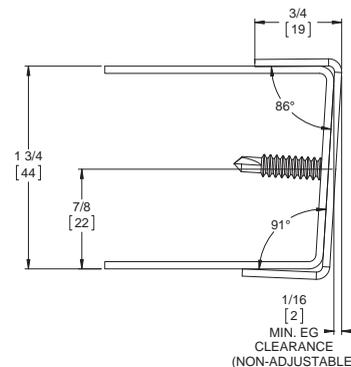

Bevel edge door

800-824-3018 | www.pemko.com
Check the web site for the up-to-date catalog

Copyright © 2015-2024, ASSA ABLOY Accessories and Door Controls Group, Inc., an ASSA ABLOY Group company. All rights reserved.
Reproduction in whole or in part without the express written permission of ASSA ABLOY Accessories and Door Controls Group, Inc. is prohibited.



Experience a safer and more open world

MARKAR EGC308 SINGLE RETURN EDGE GUARD

Standard Features

Material

Heavy-duty 16 gauge stainless steel

Finishes

US32D Satin Stainless Steel (630)

Mounting Hardware

Fasteners concealed when door is closed

Included fasteners are:

Custom 12-24 x 1¹/₁₆" S.S Phillips

Flat Head Undercut TEK Screws

Custom 12-24 x 1¹/₂" S.S. Phillips

Flat Head Particle Board Screws

Order form required, available online.

Standard Sizes

6'8", 7'0", 7'2", 8'0", 10'0"

Door Edge

Specify square or beveled

edge when ordering

(beveled edge standard)

Fire Rating

3 hours- hollow metal doors

90 minutes- hollow metal and

composite

20 minutes- wood doors



Fire-rated label

MAY NOT APPLY TO ALL WOOD DOORS. PLEASE CONSULT FACTORY FOR SPECIFIC WOOD DOOR APPLICATIONS.

Optional Features

Finish

US32 Bright Stainless Steel (629)

Scratch-Resistant Powder Coated Paint

Hardware Cutouts

(Edge Guard order form must be filled out)

Flush bolts

ASA strike

Deadlock strike and latch

86 edge

Hospital latch

161 cutout

Fasteners

Tamper-proof security screws

Other Features

Custom lengths - specify in inches

Staggered hole pattern for lead

lined doors

Custom cutouts

Dutch door application - suffix "DDP"

This fire-labeled edge guard works with the HG315 Hinge/Guard. It provides protection to the leading edge of the door, while maintaining the door's aesthetic appearance in the closed position.

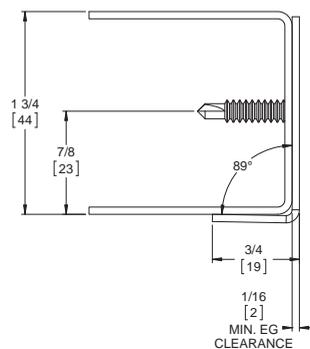

Square edge door

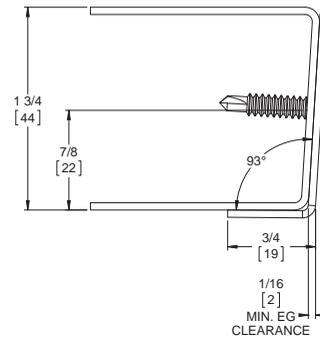

Bevel edge door



Experience a safer and more open world

800-824-3018 | www.pemko.com
Check the web site for the up-to-date catalog

Copyright © 2015-2024, ASSA ABLOY Accessories and Door Controls Group, Inc., an ASSA ABLOY Group company. All rights reserved. Reproduction in whole or in part without the express written permission of ASSA ABLOY Accessories and Door Controls Group, Inc. is prohibited.

MARKAR EGT308 ADJUSTABLE EDGE GUARD WITH ASTRAGAL

Standard Features

Material

Heavy-duty 16 gauge stainless steel

Finishes

US32D Satin Stainless Steel (630)

Mounting Hardware

Fasteners concealed when door is closed

Included fasteners are:

Custom 12-24 x 1¹/₁₆" S.S Phillips Flat Head Undercut TEK Screws

Custom 12-24 x 1¹/₂" S.S. Phillips Flat Head Particle Board Screws

Order form required, available online.

Standard Sizes

6'8", 7'0", 7'2", 8'0", 10'0"

Door Edge

Specify square or beveled edge when ordering (beveled edge standard)

Fire Rating

3 hours- hollow metal doors

90 minutes- hollow metal and composite

20 minutes- wood doors



Fire-rated label

MAY NOT APPLY TO ALL WOOD DOORS. PLEASE CONSULT FACTORY FOR SPECIFIC WOOD DOOR APPLICATIONS.

Optional Features

Finish

US32 Bright Stainless Steel (629)

Scratch-Resistant Powder Coated Paint

Hardware Cutouts

(Edge Guard order form must be filled out)

Flush bolts

ASA strike

Deadlock strike and latch

86 edge

Hospital latch

161 cutout

Fasteners

Tamper-proof security screws

Adjust-A-Screw™ for correcting frame fit problems up to 3/8"

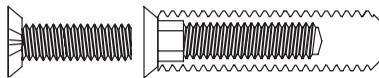

Other Features

Custom lengths - specify in inches

Staggered hole pattern for lead lined doors

Custom cutouts

Dutch door application - suffix "DDP"

Lead lined astragal with 4 lbs. lead lining - suffix "LL"

The integral overlapping astragal of the EGT308 provides additional security by protecting the latch protector. It is ideal for exterior pairs of doors or doors that require added protection from vandalism.

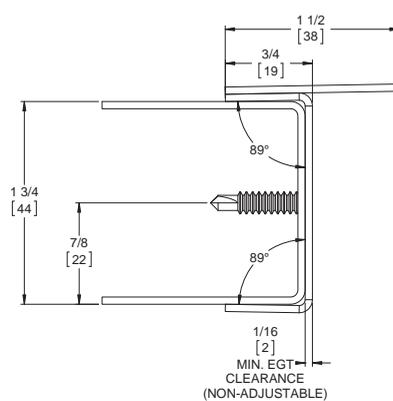

Square edge door

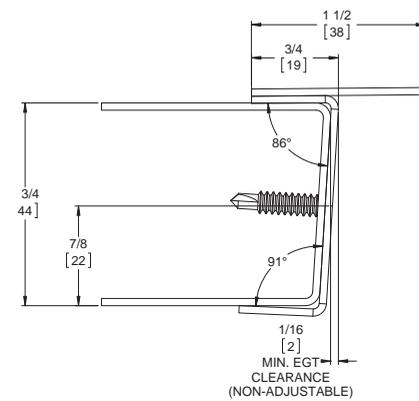

Bevel edge door

800-824-3018 | www.pemko.com

Check the web site for the up-to-date catalog

Copyright © 2015-2024, ASSA ABLOY Accessories and Door Controls Group, Inc., an ASSA ABLOY Group company. All rights reserved. Reproduction in whole or in part without the express written permission of ASSA ABLOY Accessories and Door Controls Group, Inc. is prohibited.



Experience a safer and more open world

MARKAR 200 SERIES CARBON STEEL PIN & BARREL CONTINUOUS HINGES

Short Form Architectural Specification:

Continuous hinges shall be full height piano-type hinge providing full height door support.

- Supports weights up to 600 lbs. 4'0" maximum door width
- Material to be 14 gauge 1012 carbon steel
- .187" diameter stainless steel pin (rod)
- Each knuckle 2", including nylon bearing at each separation for a quiet, smooth, self-lubricating operation
- Finish: Zinc Plated
Optional Finish: Scratch-Resistant Powder Coated Paint
- All hinges shall be furnished with manufacturer's recommended hardware pack per specific model application
- Must use undercut head screws
- Must be able to carry Warnock Hersey Int. or UL fire rated doors and frames up to 3 hours
- Hinges shall meet ANSI/BHMA Standard A 156.26 Grade 1
- Symmetrically templated hole pattern

Note: 25-Year Warranty on all Continuous Hinges

Note: Fire label for doors and frames should be placed on the header and top rail of fire rated doors and frames

MARKAR FM200 EDGE MOUNT HINGE

Standard Features

Barrel Type Hinge

.187" diameter stainless steel pin (rod)
Medical bearings
Stainless steel end pins

Material

Heavy-duty 14 gauge 1012 carbon steel

Finishes

Zinc Plated

Standards

ANSI/BHMA Standard A156.26 Grade 1

Mounting Hardware

No exposed mounting fasteners
Custom 12-24 x 11/16" S.S Phillips
Flat Head Undercut TEK Screws

Capacity

Supports weights up to 600lbs.
4'0" maximum door width

Standard Sizes

6'8", 7'0", 7'2", 8'0", 10'0"

Handing

Handing not required on standard hinges. Specify handing when ordering a hinge with modification

Fire Rating

3 hours- hollow metal doors
90 minutes- hollow metal and composite core wood fire doors
20 minutes- wood doors



Classified in accordance with
UL10C for positive pressure
Fire-rated label



Windstorm

Evaluated in accordance with TAS 201-14, TAS 202-14, TAS 203-14, ASTM E330, ASTM E1886, ASTM E1996 and ANSI A250.13

Optional Features

Finish

Scratch-Resistant Powder Coated Paint

Fasteners

Tamper-proof security screws

Other Features

Custom lengths - specify in inches
Custom hole pattern
Dutch door hinges - suffix "DDP"
Hospital tips - suffix "HT"
Raised barrel - suffix "RB"

Electrical Modifications

Current Transfer Prep (frame leaf only) - suffix "CTP"

ElectroLynx®

EL4 (4 wire), EL8 (8 wire), EL12 (12 wire)
PoE (9 wire)

This edge-mounted pin & barrel hinge is used on many traffic, high abuse interior doors. The hinge works well in locations that used anchor hinges, pivot reinforced hinges, or thrust pivot unit and hinge sets. This hinge saves on special door and frame preparation charges. It can be used on both fire labeled and non-labeled openings.

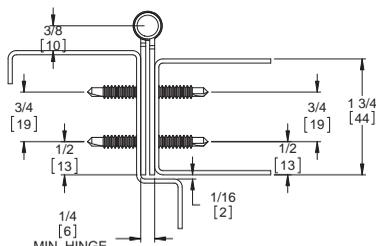

Door Closed

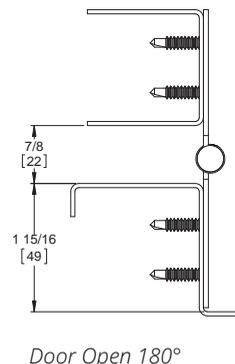

Door Open 180°



Experience a safer
and more open world

800-824-3018 | www.pemko.com
Check the web site for the up-to-date catalog

Copyright © 2015-2024, ASSA ABLOY Accessories and Door Controls Group, Inc., an ASSA ABLOY Group company. All rights reserved. Reproduction in whole or in part without the express written permission of ASSA ABLOY Accessories and Door Controls Group, Inc. is prohibited.

MARKAR HS203 HALF SURFACE

Standard Features

Barrel Type Hinge

.187" diameter stainless steel pin (rod)
Medical bearings
Stainless steel end pins

Material

Heavy-duty 14 gauge 1012 carbon steel
Cover - extruded aluminum

Finishes

Zinc Plated
Cover - Mill Finish

Standards

ANSI/BHMA Standard A156.26 Grade 1

Mounting Hardware

No exposed mounting fasteners
Custom 12-24 x 1¹¹/₁₆" S.S Phillips Flat Head Undercut TEK Screws
1/4-14 x 3/4 Security TORX TEK Screws

Capacity

Supports weights up to 600lbs.
4'0" maximum door width

Standard Sizes

6'8", 7'0", 7'2", 8'0", 10'0"

Hole Pattern

Symmetrically templated

Handing

Not required for standard 7'0", 8'0" or 10'0". Specify handing for 6'8" and 7'2" and for most optional features

Fire Rating

3 hours- hollow metal doors
90 minutes- hollow metal and composite
20 minutes- wood doors



Classified in accordance with UL10C for positive pressure



Fire-rated label

Optional Features

Finishes

Scratch-Resistant Powder Coated Paint

Fasteners

1⁵/₈" steel sleeve bolts
Tamper-proof security screws

Other Features

Custom lengths - specify in inches
Custom hole pattern
Dutch door hinges - suffix "DDP"
Hospital tips - suffix "HT"
Raised barrel - suffix "RB"
Lead-lined cover with 4 lbs. lead lining - suffix "LL"

Electrical Modifications

Current Transfer Prep (frame leaf only) - suffix "CTP"

This half-surface pin & barrel continuous hinge can be used to repair and replace existing hinges on both fire-labeled and non-labeled openings. The hinge fits into the gap left after standard butt hinges are removed. It can assist in reversing the handing of a door, or to reverse the swing of a door hung in an evenly-rabbetted frame. (Please contact the factory for instructions for unevenly-rabbetted frames.)

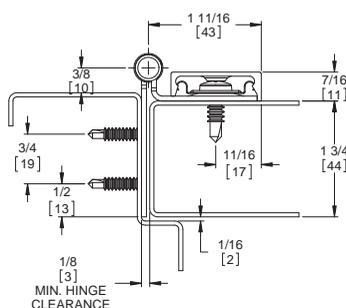

Door Closed

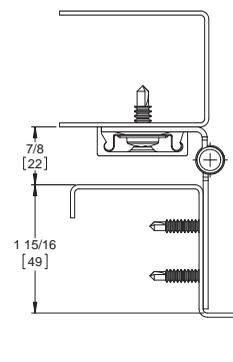

Door Open 180°

800-824-3018 | www.pemko.com

Check the web site for the up-to-date catalog

Copyright © 2015-2024, ASSA ABLOY Accessories and Door Controls Group, Inc., an ASSA ABLOY Group company. All rights reserved. Reproduction in whole or in part without the express written permission of ASSA ABLOY Accessories and Door Controls Group, Inc. is prohibited.



Experience a safer and more open world

MARKAR 100 SERIES ALUMINUM PIN & BARREL CONTINUOUS HINGES

Short Form Architectural Specification:

Continuous hinges shall be full height piano-type hinge providing full height door support.

- Supports weights up to 600 lbs. 4'0" maximum door width
- Material to be extruded aluminum 6063-T6 alloy
- .187" diameter stainless pin (rod)
- Each knuckle 2", including nylon bearing at each separation for a quiet, smooth, self-lubricating operation
- Finish: Clear Anodized (628), Dark Bronze Anodized (313)
Optional Finish: Light Bronze Anodized (311), Black Anodized (315), Scratch-Resistant Powder Coated Paint. Other finishes available upon request.
- All hinges shall be furnished with manufacturer's recommended hardware pack per specific model application
- Exterior barrel diameter .515" (1/2")
- Material thickness less than .125"
- Material weight will be no less than 1.5 lbs. per foot
- Hinges shall meet ANSI/BHMA Standard A 156.26 Grade 2
- Symmetrically templated hole pattern

Note: 25-Year Warranty on all Continuous Pin & Barrel Hinges

MARKAR FM100 EDGE MOUNT HINGE

Standard Features

Barrel Type Hinge

.187" diameter stainless steel pin (rod)
Medical bearings
Aluminum end pins

Material

6063-T6 aluminum alloy

Finishes

Clear Anodized (628)
Dark Bronze Anodized (313)

Standards

ANSI/BHMA Standard A156.26
Grade 2

Mounting Hardware

Fasteners concealed when door is closed
Custom 12-24 x 1¹/₁₆" S.S Phillips Flat
Head Undercut TEK Screws

Capacity

Supports weights up to 600lbs.
4'0" maximum door width

Standard Sizes

6'8", 7'0", 7'2", 8'0"

Hole Pattern

Symmetrically templated

Handing

Handing not required on standard hinges. Specify handing when ordering a hinge with modification

Windstorm

Evaluated in accordance with TAS 201-14, TAS 202-14, TAS 203-14, ASTM E330, ASTM E1886, ASTM E1996 and ANSI A250.13.

Optional Features

Finishes

Light Bronze Anodized (311)
Black Anodized (315)
Scratch-Resistant Powder Coated Paint

Other Features

Custom lengths - specify in inches
Custom hole pattern
Dutch door hinges - suffix "DDP"
Hospital tips - suffix "HT"

Electrical Modifications

Current Transfer Prep - suffix "CTP"
Electrical Transfer Access Prep - suffix "ETAP"

ElectroLynx®

EL4 (4 wire), EL8 (8 wire), EL12 (12 wire)
PoE (9 wire)

This door-edge mounted aluminum pin & barrel type hinge is extruded using 30% more aluminum than most geared hinges, giving it exceptional strength and durability. This product is specified in lieu of pivots or butt hinges due to its unique design which distributes the weight of the door down the entire length of the hinge.

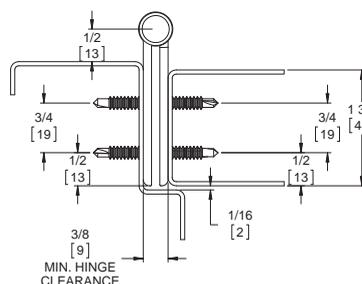

Door Closed

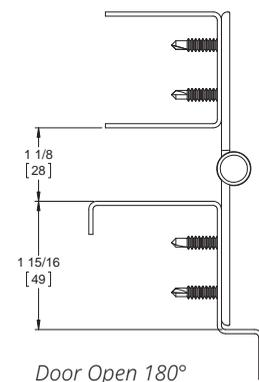

Door Open 180°



Experience a safer
and more open world

800-824-3018 | www.pemko.com
Check the web site for the up-to-date catalog

Copyright © 2015-2024, ASSA ABLOY Accessories and Door Controls Group, Inc., an ASSA ABLOY Group company. All rights reserved. Reproduction in whole or in part without the express written permission of ASSA ABLOY Accessories and Door Controls Group, Inc. is prohibited.

MARKAR FS102 FULL SURFACE FLUSH MOUNT HINGE

Standard Features

Barrel Type Hinge

- .187" diameter stainless steel pin (rod)
- Medical bearings
- Aluminum end pins

Material

6063-T6 aluminum alloy

Finishes

- Clear Anodized (628)
- Dark Bronze Anodized (313)

Standards

ANSI/BHMA Standard A156.26 Grade 2

Mounting Hardware

- Fasteners concealed when door is closed
- 1/4"-14 x 3/4" Security TORX TEK Screws

Capacity

- Supports weights up to 600lbs.
- 4'0" maximum door width

Standard Sizes

6'8", 7'0", 7'2", 8'0"

Locking Security Covers

Brushed aluminum finish

Handing

- Not required for standard 7'0" or 8'0".
- Handing required for 6'8" and 7'0" and for most optional features listed

Optional Features

Finish

- Light Bronze Anodized (311)
- Black Anodized (315)
- Scratch-Resistant Powder Coated Paint

Fasteners

- 1 5/8" aluminum sleeve bolts
- Tamper-proof security screws

Other Features

- Custom lengths - specify in inches
- Custom hole pattern
- Dutch door hinges - suffix "DDP"
- Hospital tips - suffix "HT"
- Lead lined cover with 4 lbs. lead lining - suffix "LL"

For flush-mounted doors. This surface-mounted pin & barrel type continuous hinge is for flush-mounted doors for solving your door sag problems. This unit works well on all types of aluminum, wood and hollow metal door applications. The hinge also features tamper-resistant cover caps to prevent vandalism or break-ins.

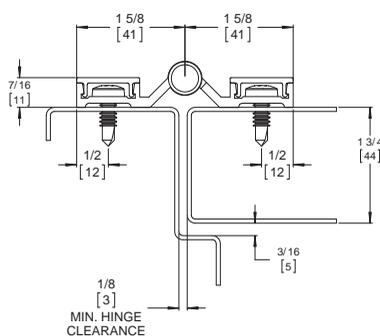

Door Closed

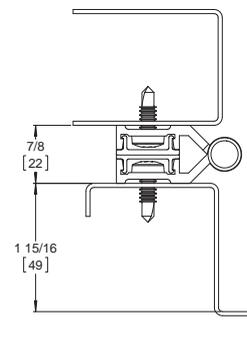

Door Open 180°

MARKAR 900 SERIES SPRING LOADED PIN & BARREL TYPE CONTINUOUS STAINLESS STEEL HINGES

Short Form Architectural Specification:

Continuous hinges shall be full height piano-type hinge providing full height door support.

- Supports weights up to 80 lbs. 3'0" maximum door width
- Material to be 14 gauge stainless steel
- Patented .25" diameter 303 stainless steel self closing pin assembly
- Exterior barrel diameter .438" (7/16")
- Adjustable, tamper resistant Torx Head end caps
- Each knuckle 2", including split nylon bearing at each separation for a quiet, smooth, self-lubricating operation
- Finish: US32D Satin Stainless Steel (630)
Optional Finish: US32 Bright Stainless Steel (629)
- Non-Handed
- All hinges shall be furnished with manufacturer's recommended hardware pack per specific model application
- Removable roll pin for spring loaded adjustment
- Symmetrically templated hole pattern

Note: 10-Year Warranty

MARKAR FM900 EDGE MOUNT

Standard Features

Spring-Loaded Barrel Type Hinge
.25" diameter stainless steel pin with stainless steel spring mechanism
Torx tip cap to adjust spring tension
Split nylon bearings

Material

Heavy-duty 14 gauge stainless steel
Finishes
US32D Satin Stainless Steel (630)

Torx Adjusting Screw
Adjust tension on door to close tightly for out-swinging ADA compliance

Mounting Hardware

Custom 12-24 x 1 1/16" S.S Phillips Flat Head Undercut TEK Screws
Capacity
Close door weighing up to 80 lbs.

Sizes

54", 57"

Non-Handed

Use the same hinge for right- or left-handed doors

For Doors over 3'0" consult factory

USA patent no. 4823437

Canadian patent no. 1303804

Optional Features

Finishes

US32 Bright Stainless Steel (629)
Scratch-Resistant Powder Coated Paint

Fasteners

Tamper-proof security screws

Other Features

Custom lengths -Custom sizes 24" to 72" available
Custom hole pattern

Ideal for damp or corrosive environments, Markar's stainless steel toilet partition hinge adds years of life to your high-quality partition.

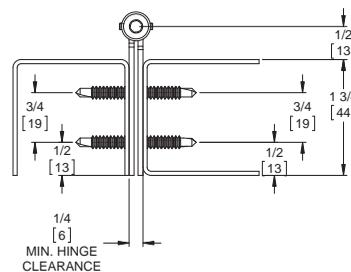

Door Closed

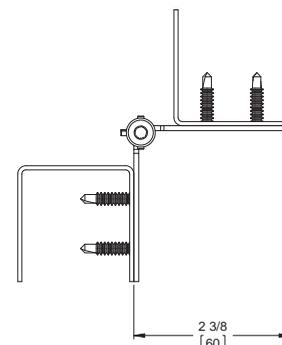

Door Open 90°



Experience a safer and more open world

800-824-3018 | www.pemko.com
Check the web site for the up-to-date catalog

Copyright © 2015-2024, ASSA ABLOY Accessories and Door Controls Group, Inc., an ASSA ABLOY Group company. All rights reserved. Reproduction in whole or in part without the express written permission of ASSA ABLOY Accessories and Door Controls Group, Inc. is prohibited.

MARKAR FS902 FLUSH FULL SURFACE HINGE

Standard Features

Spring-Loaded Barrel Type Hinge
 .25" diameter stainless steel pin with stainless steel spring mechanism
 Torx tip cap to adjust spring tension
 Split nylon bearings

Material

Heavy-duty 14 gauge stainless steel
 Covers - extruded aluminum

Finishes

US32D Satin Stainless Steel (630)
 Covers - Brushed Aluminum
 Torx Adjusting Screw
 Adjust tension on door to close tightly for out-swinging ADA compliance

Mounting Hardware

1/4" x 20 pan head pan head machine screws
 Concealed by cover caps

Capacity

Close door weighing up to 80 lbs.

Sizes

54", 57"

Non-Handed

Use the same hinge for right- or left-handed doors

For Doors over 3'0" consult factory

USA patent no. 4823437

Canadian patent no. 1303804

Optional Features

Finishes

US32 Bright Stainless Steel (629)
 Scratch-Resistant Powder Coated Paint

Fasteners

Tamper-proof security screws

Ideal for damp or corrosive environments, Markar's stainless steel toilet partition hinge adds years of life to your high-quality partition.

Other Features

Custom lengths - Custom sizes
 24" to 72" available
 Custom hole pattern

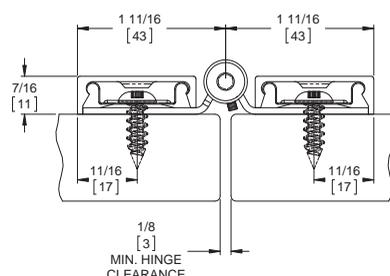

Door Closed

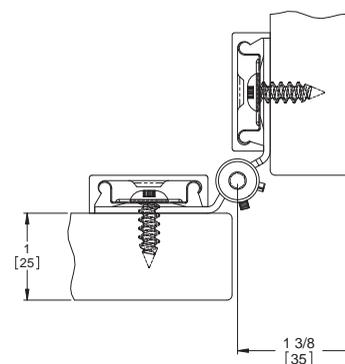

Door Open 90°

MARKAR FS910 FLUSH FULL SURFACE HINGE

Standard Features

Spring-Loaded Barrel Type Hinge
 .25" diameter stainless steel pin with stainless steel spring mechanism
 Torx tip cap to adjust spring tension
 Split nylon bearings

Material

Heavy-duty 14 gauge stainless steel

Finishes

US32D Satin Stainless Steel (630)
 Torx Adjusting Screw
 Adjust tension on door to close tightly for out-swinging ADA compliance

Mounting Hardware

Custom 12-24 x 11/16" S.S Phillips Flat Head Undercut TEK Screws

Capacity

Close door weighing up to 80 lbs.

Sizes

54", 57"

Non-Handed

Use the same hinge for right- or left-handed doors

For Doors over 3'0" consult factory

USA patent no. 4823437

Canadian patent no. 1303804

Optional Features

Finishes

US32 Bright Stainless Steel (629)
 Scratch-Resistant Powder Coated Paint

Fasteners

Tamper-proof security screws

Other Features

Custom lengths - Custom sizes
 24" to 72" available Custom hole pattern

Ideal for damp or corrosive environments, Markar's stainless steel toilet partition hinge adds years of life to your high-quality partition.

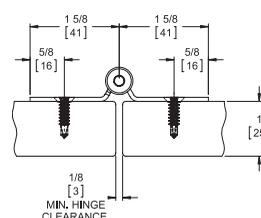

Door Open

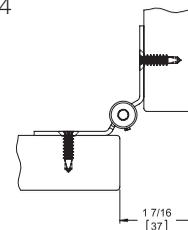

Door Open

MARKAR 400 SERIES SPRING LOADED PIN & BARREL TYPE CONTINUOUS ALUMINUM HINGES

Short Form Architectural Specification:

Continuous hinges shall be full height piano-type hinge providing full height door support.

- Supports weights up to 80 lbs. 3'0" maximum width
- Material to be extruded aluminum 6063-T6 alloy
- Patented .25" diameter 303 stainless steel self closing pin assembly
- Each knuckle 2", including split nylon bearing at each separation for a quiet, smooth, self-lubricating operation
- Finish: Clear Anodized (628). Other finishes available upon request.
- Adjustable, tamper resistant Torx Head end caps
- Non-handed
- Exterior barrel diameter .515" (1/2")
- Material thickness less than .125"
- Removable roll pin for spring loaded adjustment
- Symmetrically templated hole pattern

Note: 10-Year Warranty

MARKAR FM400 EDGE MOUNT HINGE

Standard Features

Spring-Loaded Barrel Type Hinge
 .25" diameter stainless steel pin with stainless steel spring mechanism
 Torx tip cap to adjust spring tension
 Split nylon bearings

Material
 6063-T6 aluminum alloy

Finishes
 Clear Anodized (628)
 Torx Adjusting Screw
 Adjust tension on door to close tightly for out-swinging ADA compliance

Mounting Hardware
 Custom 12-24 x 11/16" S.S Phillips Flat Head Undercut TEK Screws

Capacity
 Close door weighing up to 80 lbs.

Sizes
 54", 57"
 Non-Handed
 Use the same hinge for right- or left-handed doors
 For Doors over 3'0" consult factory
 USA patent no. 4823437
 Canadian patent no. 1303804

Optional Features

Fasteners
 Tamper-proof security screws

Finishes
 Scratch-Resistant Powder Coated Paint
 Light Bronze Anodized (311)
 Black Anodized (315)

Other Features
 Custom lengths - Custom sizes 24" to 72" available
 Custom hole pattern
 Lift-up safety feature

Specify Markar to create the total finished look that your high-quality toilet partition deserves. The Markar continuous spring hinge gives a clean, finished look while virtually eliminating the "sight line" that multi-part systems cause. Continuous hinges also give complete support along the entire length of the partition door.

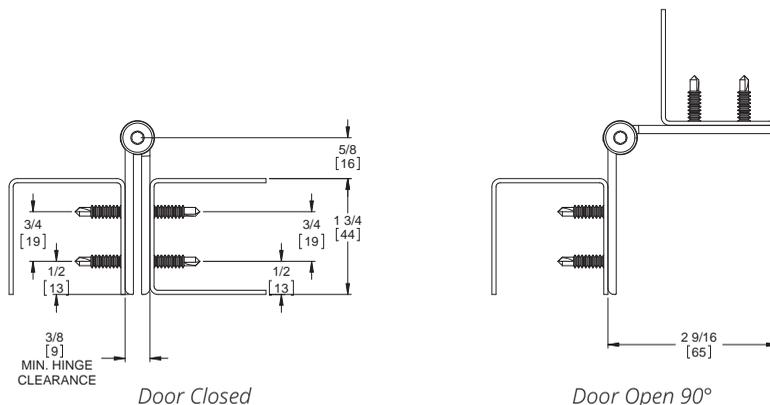

Experience a safer and more open world

800-824-3018 | www.pemko.com
 Check the web site for the up-to-date catalog

Copyright © 2015-2024, ASSA ABLOY Accessories and Door Controls Group, Inc., an ASSA ABLOY Group company. All rights reserved. Reproduction in whole or in part without the express written permission of ASSA ABLOY Accessories and Door Controls Group, Inc. is prohibited.

MARKAR FS402 FLUSH FULL SURFACE HINGE

Standard Features

Spring-Loaded Barrel Type Hinge

.25" diameter stainless steel pin with stainless steel spring mechanism
Torx tip cap to adjust spring tension
Split nylon bearings

Material

6063-T6 aluminum alloy
Covers - extruded aluminum

Finishes

Clear Anodized (628)
Torx Adjusting Screw
Adjust tension on door to close tightly for out-swinging ADA compliance

Mounting Hardware

1/4" x 20 pan head machine screws
Concealed by cover caps

Capacity

Close door weighing up to 80 lbs.

Sizes

54", 57"

Non-Handed

Use the same hinge for right- or left-handed doors
For Doors over 3'0" consult factory
USA patent no. 4823437
Canadian patent no. 1303804

Optional Features

Fasteners

Tamper-proof security screws

Finishes

Scratch-Resistant Powder Coated Paint
Light Bronze Anodized (311)
Black Anodized (315)

Other Features

Custom lengths - Custom sizes 24" to 72" available
Custom hole pattern
Lift-up safety feature

Specify Markar to create the total finished look that your high-quality toilet partition deserves. The Markar continuous spring hinge gives a clean, finished look while virtually eliminating the "sight line" that multi-part systems cause. Continuous hinges also give complete support along the entire length of the partition door.

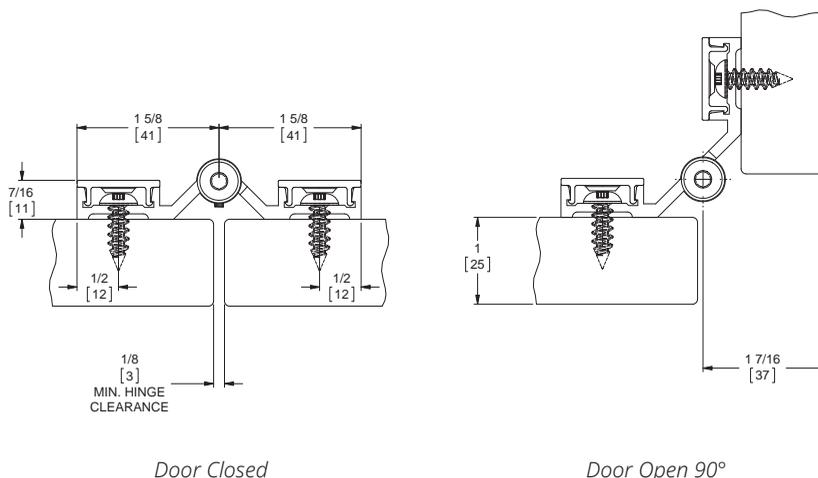

MARKAR B1923 FULL SURFACE REINFORCING PIVOT

This full-surface reinforcing pivot adds years of life to openings where the hinges or hinge reinforcements have failed. An economical way to solve door sag problems, reinforcing pivots take the load off the top hinge and transfer it to screws that will not pull out.

Material:

Heavy Duty $\frac{3}{16}$ " (.187) Cold-Rolled Steel

Finish:

Zinc Plated (US2G)

Mounting:

8 ea. $\frac{1}{4}$ -20 x $\frac{3}{4}$ " Phillips flat head machine screws

8 ea. #14 x $1\frac{1}{4}$ " Phillips flat head sheet metal screws

2 ea. $\frac{1}{4}$ -20 x $1\frac{3}{4}$ " Sleeve bolts

Capacity:

Supports Weights up to 300 lbs.

Hole Pattern:

Symmetrically

Handing:

Non-handed

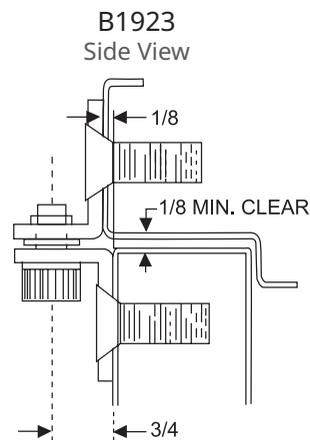
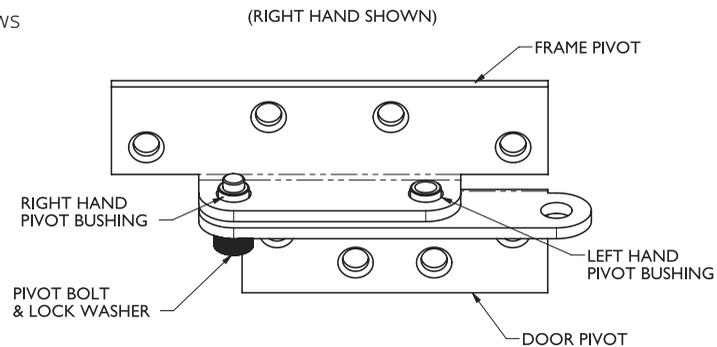

Matches $4\frac{1}{2}$ " hinge barrel centerline

B1923

The B1923 pivot is designed with a $\frac{3}{4}$ " offset to match the pivot point of a $4\frac{1}{2}$ " wide butt hinge.

PEMCO
ASSA ABLOY

Experience a safer
and more open world

800-824-3018 | www.pemko.com
Check the web site for the up-to-date catalog

Copyright © 2015-2024, ASSA ABLOY Accessories and Door Controls Group, Inc., an ASSA ABLOY Group company. All rights reserved. Reproduction in whole or in part without the express written permission of ASSA ABLOY Accessories and Door Controls Group, Inc. is prohibited.

MARKAR FLAT ASTRAGALS

- For 6'8", 7'0", and 8'0" doors
- Holes are countersunk and equally spaced
- 1/8" x 2" galvanized steel
- 1-pkg. # 6 x 1" F.H.S.M. screws
- Finish – galvanized steel
- Available with thru-bolt option– nine-pack (ZTB-KIT9) or eleven-pack (ZTB-KIT11)

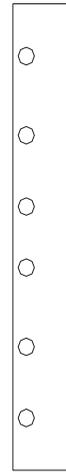

FA68

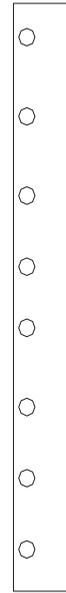

FA70

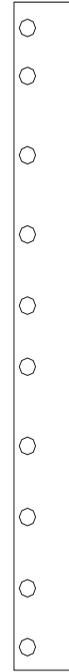

FA80



Experience a safer
and more open world

800-824-3018 | www.pemko.com
Check the web site for the up-to-date catalog

Copyright © 2015-2024, ASSA ABLOY Accessories and Door Controls Group, Inc., an ASSA ABLOY Group company. All rights reserved.
Reproduction in whole or in part without the express written permission of ASSA ABLOY Accessories and Door Controls Group, Inc. is prohibited.

MARKAR UNIVERSAL SCREW PACKS – EDGE MOUNT HINGES

For hinge models FM100

Screw type	Aluminum	Bronze	6'8"-7'0"-7'2"	8'0"	10'0"
12-24 x 1 ¹ / ₁₆ " Phillips flat head undercut self-drilling Tek screw	TKS1267SP10SS	TKS1267SP10BLR	42	46	54

For hinge models FM200, FM300, HG311, HG315, HG329, FM600

Screw type	Stainless Steel	6'8"-7'0"-7'2"	8'0"	10'0"
12-24 x 1 ¹ / ₁₆ " Phillips flat head undercut self-drilling Tek screw	TKS1267SP10SS	42	46	54

For hinge/guard models HG305, HG310, HG326,

Screw type	Stainless Steel	6'8"-7'0"-7'2"	8'0"	10'0"
12-24 x 1 ¹ / ₁₆ " Phillips flat head undercut self-drilling Tek screw	TKS1267SP10SS	42	46	54
Adjust-A-Screw™ option	Stainless Steel	6'8"-7'0"-7'2"	8'0"	10'0"
10-32 x 3/4" Phillips flat head undercut machine screw	MS10075SS	21	23	27
1 ³ / ₈ " Adjust-A-Screw™ with 10-32 internal thread	M26-0031-01	21	23	27

For hinge/guard model HG323

Screw type	Stainless Steel	6'8"-7'0"-7'2"	8'0"	10'0"
12-24 x 1 ¹ / ₁₆ " Phillips flat head undercut self-drilling Tek screw	TKS1267SP10SS	21	23	27
1/4-20 X 3/4" Truss Head Phillips machine screw	MS14075TSS	9	9	11
1/4-20 x 1 ⁵ / ₈ " sleeve bolt	TB1420SS	9	9	11

For edge/guard models EG308, EGC308, & EGT308

Screw type	Stainless Steel	6'8"-7'0"-7'2"	8'0"	10'0"
#12 x 1 ¹ / ₂ Phillips flat head undercut sheet metal screw	PBS12150SP10SS	8	10	12
#12-24 x 1 ¹ / ₁₆ " Phillips flat head undercut self-drilling Tek Screw	TKS1267SP10SS	8	10	12

For security hinge models FM3500, FS3501, & FS3502

Screw type	Stainless Steel	6'8"-7'0"-7'2"	8'0"	10'0"
12-24 x 7/16" flat head undercut machine screw	MS1244SP10SS	42	46	54

MARKAR UNIVERSAL SCREW PACKS – FULL SURFACE HINGES

For models FS102

Screw type	Aluminum	Bronze	6'8"-7'0"-7'2"	8'0"	10'0"
1/4-14 x 3/4" Torx pan head self-drilling Tek screw	TORX-TKS14075R	TORX-TKS14075R	32	36	40
#8 x 3/4" Phillips flat head Tek screw	TKS8075Z	S323-08R12-663	4	4	4

For models FS301 & FS302

Screw type	Stainless Steel	6'8"-7'0"-7'2"	8'0"	10'0"
1/4-14 x 3/4" Torx pan head self-drilling Tek screw	TORX-TKS14075R	32	36	40
606 Cover clips	M22-0130-01	10	12	16
#8 x 3/4" Phillips flat head Tek screw	TKS8075Z	4	4	4

For swing clear model FS/SC309

Screw type	Stainless Steel	6'8"-7'0"-7'2"	8'0"	10'0"
12-24 x 11/16" Phillips flat head undercut self-drilling Tek screw	TKS1267SP10SS	22	24	28
1/4-14 x 3/4" Torx Phillips pan head self-drilling Tek screw	TORX-TKS14075R	16	18	20
606 Cover clips	M22-0130-01	5	6	8
#8 x 3/4" Phillips flat head Tek screw	TKS8075Z	2	2	2

UNIVERSAL SCREW PACKS – HALF SURFACE & HALF MORTISE HINGES

For hinge models HS203

Screw type	Stainless Steel	6'8"-7'0"-7'2"	8'0"	10'0"
1/4-14 x 3/4" Torx pan head self-drilling Tek screw	TORX-TKS14075R	14	16	20
12-24 x 11/16" Phillips flat head undercut self-drilling Tek screw	TKS1267SP10SS	21	23	27
606 Cover clips	M22-0130-01	5	6	8
#8 x 3/4" Phillips flat head sheet metal screw	TKS8075Z	2	2	2

For hinge models HS303 & HM304

Screw type	Stainless Steel	6'8"-7'0"-7'2"	8'0"	10'0"
1/4-14 x 3/4" Torx pan head self-drilling Tek screw	TORX-TKS14075R	14	16	20
12-24 x 3/16" Phillips flat head undercut self-drilling Tek screw	TKS1267SP10SS	21	23	27
606 Cover clips	M22-0130-01	5	6	8
#8 x 3/4" Phillips flat head sheet metal screw	TKS8075Z	2	2	2



Experience a safer
and more open world

800-824-3018 | www.pemko.com
Check the web site for the up-to-date catalog

Copyright © 2015-2024, ASSA ABLOY Accessories and Door Controls Group, Inc., an ASSA ABLOY Group company. All rights reserved.
Reproduction in whole or in part without the express written permission of ASSA ABLOY Accessories and Door Controls Group, Inc. is prohibited.

MARKAR UNIVERSAL SCREW PACKS – TOILET PARTITION HINGES

For hinge models FM400

Screw type	Stainless Steel	54"	57"
12-24 x ¹¹ / ₁₆ " Phillips flat head undercut zinc self-drilling Tek screw	TKS1267SP10SS	26	26
³ / ₃₂ " x ³ / ₈ " Stainless Steel roll pin	RLPN33238SS	1	1

For hinge model FS402

Screw type	Stainless Steel	54"	57"
¹ / ₄ -14 x ³ / ₄ " Torx button head sheet metal screw	TORX-TKS14075R	12	12
#8 x ³ / ₄ " TORX flat head self-drilling Tek screw	TORX-TKS8075Z	4	4
³ / ₃₂ " x ³ / ₈ " Stainless Steel roll pin	RLPN33238SS	1	1

For hinge models FM900

Screw type	Stainless Steel	54"	57"
#12-24 x ¹¹ / ₁₆ " Phillips flat head undercut self-drilling Tek screw	TKS1267SP10SS	26	26
³ / ₃₂ " x ³ / ₈ " Stainless Steel roll pin	RLPN33238SS	1	1

For hinge model FS902

Screw type	Stainless Steel	54"	57"
¹ / ₄ -14 x ³ / ₄ " Torx button head sheet metal screw	TORX-TKS14075R	12	12
606 Cover clips	M22-0130-01	6	6
#8 x ³ / ₄ " TORX flat head self-drilling Tek screw	TORX-TKS8075Z	4	4
³ / ₃₂ " x ³ / ₈ " Stainless Steel roll pin	RLPN33238SS	1	1

For hinge models FS910

Screw type	Stainless Steel	54"	57"
#12-24 x ¹¹ / ₁₆ " Phillips flat head undercut self-drilling Tek screw	TKS1267SP10SS	26	26
³ / ₃₂ " x ³ / ₈ " Stainless Steel roll pin	RLPN33238SS	1	1

MARKAR FASTENERS

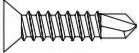
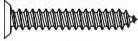
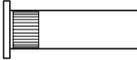
	Product Number	Description	Properties
		Custom 12-24 x 1 ¹¹ / ₁₆ " Phillips Flat Head Undercut Self-Drilling Screw	
	TKS1267SP10SS	For attaching Edge Mounted hinge leaves	Stainless Steel Phillips
	TORX-TKS1267SP10SS	For attaching Edge Mounted hinge leaves	Stainless Steel Torx
		#8 x 3/4" Flat Head Self Drilling Tek Screw	
	TKS8075Z	For attaching 100, 200, and 300 series covers	Zinc Phillips
	S323-08R12-663	For attaching 100, 200, and 300 series covers	Bronze Phillips
	TORX-TKS8075Z	For attaching 100, 200, and 300 series covers	Zinc Torx
		Custom #12 x 1 ¹ / ₂ " Flat Head Undercut Particle Board Screw	
	PBS12150SP10BLR	For edge mounting to wood	Bronze Phillips
	PBS12150SP10SS	For edge mounting to wood	Stainless Steel Phillips
	TORX-PBS12150SP10SS	For edge mounting to wood	Stainless Steel Torx
		Custom 12-24 x 7/16" Flat Head Undercut Machine Screw	
	MS1244SP10SS	Used with 3500 series hinges for mounting to metal	Stainless Steel Phillips
	TORX-MS1244SP10SS	Used with 3500 series hinges for mounting to metal	Stainless Steel Torx
		10-32 x 3/4" Flat Head Machine Screw	
	MS10075SS	Used with Adjust-A-Screw	Stainless Steel Phillips
	TORX-MS10075SS	Used with Adjust-A-Screw	Stainless Steel Torx
		1/4-20 x 1 ⁵ / ₈ " Sleeve Bolt	
	TB1420SS	For surface mounting to wood	Stainless Steel
		10-24 Security Button Head Barrel Nut	
	M26-0030	For surface mount toilet partition hinges Consult factory for pricing and availability	Stainless Steel
		10-24 x 3/4" Button Head Security Torx	
	TORX-BHMS1075SS	For surface mount toilet partition hinges Consult factory for pricing and availability	Stainless Steel

MARKAR FASTENERS

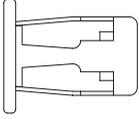
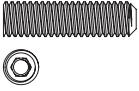
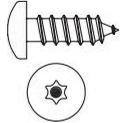
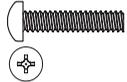
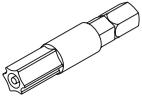
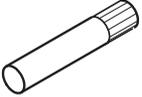
	Product Number	Description	Properties
	M26-0015-02	18 SJN 1/4-20 Molly Jack Nut 7/16" hole	Zinc
	M26-0031-01	1 3/8" Adjust-A-Screw™ with 10-32 Internal Thread and Hex Head Adjustment Used with MS10075SS screw Note: 5/16" pilot hole required for 3/8" - 16 tap	
	TORX-TKS14075R	1/4-14 x 3/4" T-27 Torx Button Head Sheet Metal Screw	Ruspert Coat Torx
	S222-416R16-603	1/4-20 x 1" Pan Head Machine Screw For surface mounting to metal	Zinc Phillips
	TORXBIT20 TORXBIT27	MT-T20, 27, & 15 Torx Driver Bit Used on TORX-MS1244SP10SS, TORX-PBS12150SP10SS and TORX-MS10075SS Used on TORX-TKS14075R16 and to adjust 400 and 900 series spring-loaded hinges	
	RLPN33238SS	Knurl Pin Replacement pin for spring-loaded toilet partition hinges	

CUTTING PIN & BARREL HINGES TO CUSTOM LENGTHS

- Step 1** The following instructions will apply to all Markar pin and barrel hinges except for toilet partition hinges. The general instructions apply for the 100, 200, 300 and 3500 series hinges. Follow option **A** for specific directions related to 100 series aluminum hinges and option **B** or **C** for specific directions related to 200, 300 & 3500 series steel and stainless steel hinges.
- Step 2** Determine the amount the hinge needs to be shortened. Note the hand of the hinge before beginning to lay out your cut. All cuts should be done at the bottom of your hinge assembly so that the gang hole pattern is at the top.
- Step 3** Measure from the top of the hinge down and mark a cut line at the desired length.
For 200, 300 & 3500 series hinges, follow the instructions below
- If less than $\frac{3}{4}$ " of knuckle is remaining follow option **B**
 - If $\frac{3}{4}$ " or more of knuckle is remaining follow option **C**
- Step 4** Cut the hinge to length with a hacksaw or horizontal band saw, going through each hinge leaf, barrel and rod. If necessary, use a file to remove sharp edges and deburr.
- Step 5** Slide the stainless steel rod out approximately 1" making sure the assembly stays together as one unit.
- **A B** Remove $\frac{1}{4}$ " from the rod using hacksaw and then push back into it's original position.
 - **C** Remove $\frac{3}{4}$ " from the rod using a hacksaw and then push back into it's original position.
- Step 6** Follow instructions below based on option used.
- **A** Using a hammer and a center-punch, swage the aluminum material towards the center of the hole locking the hinge pin into place making sure it will not slide out.
 - **B** Using a pair of vice-grips, crimp the end of the steel barrel making sure the hinge pin will not slide out.
 - **C** Remove the end of the pin from the scrap hinge and insert it into the bottom of hinge using hammer.

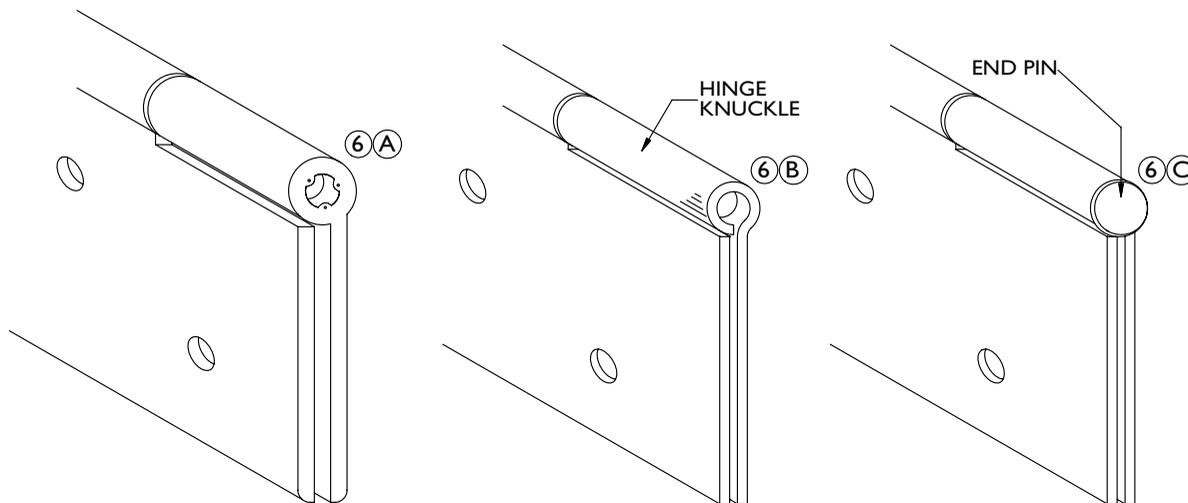

PemkoHinge®

Continuous Geared Aluminum Hinges



CONTENTS:

What is PemkoHinge®?	66
Ordering Chart	66
BHMA Certification Program	67
Hospital Tip.....	67
Cycle Requirements and Weight Bearing	67
UL Fire Labeling.....	67
Options for Electrically Modified Continuous Geared Hinges	68
X-Series PemkoHinge®	69
Offset Hinges	70
Full Mortise Hinges.....	71
Special Full Mortise Hinges.....	72
Kawneer Full Mortise Hinges.....	73
Raised Gear Hinge.....	73
Full Mortise Safety Hinges.....	74
Wide Throw Full Mortise Hinges.....	75
Wide Throw Half Surface Hinges	75
Half Surface Hinges	76
Half Mortise Hinges.....	76
Full Surface Hinges.....	77
Full Surface Center Pivot Hinges	77
Full Surface Balanced Pivot Hinge.....	77
Full Mortise Residential Hinges.....	78
Firepins™.....	79
Double Swing Hinge.....	80
Emergency Release Stop.....	80
1000 Series Aluminum Double Swing Hinge.....	81
Power Transfer Units.....	82

INDEX:

PRODUCT	PAGE	PRODUCT	PAGE	PRODUCT	PAGE
DSH	80	FM_SLI.....	71	SPFM	72
DSH1000.....	81	FM_SLISF.....	74	SPFM_SLF	72
EL-CEPT	82	FS.....	77	SPFM_SLI.....	72
EL-EPT.....	82	FS_CP.....	77	WT_FM.....	75
EL-EPTL.....	82	HM.....	76	WT_HS.....	75
EL-EPT-SC.....	82	HS.....	76	X25M.....	69
ERS	80	HS_SF.....	76	XF.....	69
FM.....	71	K_FM	73	XI.....	69
FM_RG	73	OS_FM	70	XK.....	69
FM_SF.....	74	OS_HS.....	70	XM.....	69
FM_SLF.....	71	RS138.....	78		
FM_SLF138.....	74	RS175.....	78		

NOTE: Products shown in this section may not be drawn to scale

800-824-3018 | www.pemko.com

Check the web site for the up-to-date catalog

Copyright © 2015-2024, ASSA ABLOY Accessories and Door Controls Group, Inc., an ASSA ABLOY Group company. All rights reserved.
 Reproduction in whole or in part without the express written permission of ASSA ABLOY Accessories and Door Controls Group, Inc. is prohibited.

PEMKO
ASSA ABLOY

Experience a safer
 and more open world

What is PemkoHinge®?

PemkoHinge® consists of two full-height, paired and geared leaves. Each geared leaf rotates evenly from top to bottom riding on proprietary polymer blended bearings. The geared leaves and bearings are held together by a full-length channel cap. This assembly retains the smooth, clean lines of the door and frame, while easily supporting heavy vertical loads.

PemkoHinge®

SECURITY, SAFETY, PRIVACY, LOW WEAR AND TEAR

PemkoHinge® Attributes:

- With a continuous hinge, typical alignment problems (such as door sag and binding) are eliminated
- The continuous hinge distributes load stress uniformly along the full length of the door and frame
- The gear design of the continuous hinge ensures symmetrical operation of each leaf
- 1/2 lb. or less operating force required to operate most doors, regardless of size
- Low operating force feature makes continuous hinges ideal for doors used by the physically challenged
- The continuous hinge, when installed on standard steel doors and frames, requires no additional reinforcement. However, hinge preps must have fillers installed for proper operation
- A high degree of security can be achieved for exterior openings or restricted spaces by using a continuous hinge. With the geared construction and the full-length channel cap, the common gap between the door and frame is sealed, which provides security against prying
- In addition, the continuous full-height hinge cap protects against pinching fingers in doors in public areas, particularly those where children are present
- Sight proof design of the continuous hinge provides privacy for lavatories, executive offices, or file rooms

PemkoHinge® Superior Design:

- PemkoHinge® has increased critical stress points of the hinge leaf extrusions providing additional strengths and rigidity to the completed product
- PemkoHinge® bearing design eliminates premature wear, guarantees proper alignment, and requires fewer bearings to carry more weight. The bearing is produced for Pemko using a chemical composition and injection process that provides a stronger, more accurately formed bearing
- PemkoHinge® is designed with inter-meshing gear segments in the hinge which provide 50% more bearing surface resulting in less wear
- PemkoHinge® goes through the anodizing process after completing all machining. This means the machined aluminum surfaces that are in direct contact with the bearing have a smoother, harder surface, thereby reducing wear
- PemkoHinge® maintains uniform bearing spacing for the full length of the hinge even when lengths exceed 10'
- Pemko uses self drilling No.12-24 x 11/16" Flat Head Undercut, Type C, thread-forming fasteners, no tapping required
- PemkoHinge® commercial models are ideal for use on lead lined doors (i.e. hospital X-ray rooms), without requiring special screw locations

How To Order (Hinge Part Designations)

Example: D | SPFM | 85 | SLI | HD1

FINISHES		HINGE TYPES		LENGTHS	HINGE OPTIONS		CAPACITY	
BL	Black Anodized	FM	Full-Mortise	79	"blank"	Standard	"blank"	Standard Duty
BSP	Black Suede Powder Coat*	FS	Full-Surface	83	CP	Center Pivot	HD1	Heavy Duty, Grade 1
C	Clear Anodized	HS	Half-Surface	85	RG	Raised Gear	HD3	Heavy Duty, Grade 3
D	Dark Bronze Anodized	RS138	Full-Mortise Residential: 1 ³ / ₈ "	95	SF	Safety		
G	Gold Powder Coat	RS175	Full-Mortise Residential: 1 ³ / ₄ "	120	SL	Short Leaf (residential only)		
SN	Satin Nickel Powder Coat	SPFM	Special Full-Mortise		SLF	Short Leaf Flush		
WSP	White Suede Powder Coat *	WT_FM	Wide Throw Full-Mortise		SLI	Short Leaf Inset		
10BE	Satin Bronze Powder Coat *	WT_HS	Half-Surface					

*Only available on select profiles



Experience a safer and more open world

800-824-3018 | www.pemko.com
Check the web site for the up-to-date catalog

Copyright © 2015-2024, ASSA ABLOY Accessories and Door Controls Group, Inc., an ASSA ABLOY Group company. All rights reserved. Reproduction in whole or in part without the express written permission of ASSA ABLOY Accessories and Door Controls Group, Inc. is prohibited.

BHMA Certification Program

This program was developed to establish product classifications through performance testing. Three grades (1, 2 and 3) of product classifications were established for continuous hinges, with three weight groups (150, 300 and 600) for each grade: Grade 3 being the lowest and Grade 1 being the highest classification. Each classification and weight group has a set of established cycle requirements and wear characteristics, with a minimum for vertical and lateral wear to establish a listing under a weight and grade classification, after the set number of cycles is completed.

Maximum Vertical Wear Allowable:

Grade 3 = 0.105"

Grade 2 = 0.030"

Grade 1 = 0.020"

Maximum Lateral Wear Allowable:

All Grades = 0.062"

Cycle requirements range from Grade 3-600 requiring 100,000 cycles through Grade 1-150 requiring 2.5 million cycles.

For more information on certification testing or other product certification programs, please contact Pemko Customer Service.



Hospital Tip

A special modification is available for certain hinges which provides a Hospital Tip Cap at the top of the gear cap, leaving no opening. A 45° angled cut on the gear cap and leaf covers provides a safe environment for hospitals and correctional facilities.

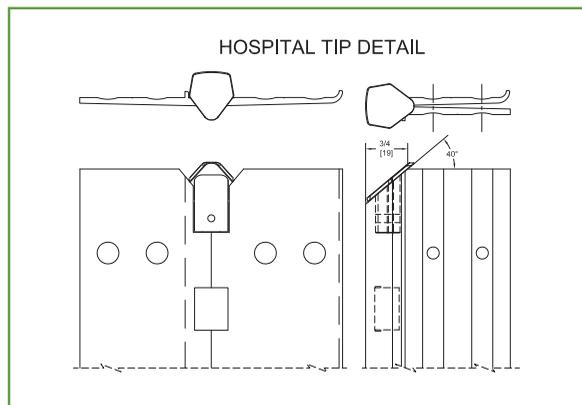

Cycle Requirements - Per BHMA Standard ANSI/BHMA A156.26-2012

- Standard Duty Hinges (excluding _RS175 & _RS138) conform to Grade 3-150 and Grade 3-300
- HD3 Hinges conform to Grade 3-150, Grade 3-300, and Grade 3-600
- HD1 Hinges conform to Grade 2-150, Grade 1-300, and Grade 1-600
- 1100 Series and X-Series Hinges conform to Grade 1-150

Weight Bearing - Per BHMA Standard ANSI/BHMA A156.26-2012

- This information pertains to all commercial models
- Heavier weight can be carried; please contact Customer Service for applications other than those listed in the chart
- Special hinge reinforcements are not required as hollow metal door and frame manufacturers' standard are acceptable. Removal of hinge reinforcements in the door and frame is not advised. Hinge preps must have fillers installed

UL Fire Labeled 1½ & 3 Hour



- All models designated with these symbols are tested and certified by Underwriters Laboratories Inc.® (U.S.A. and Canada) to standards UL10B, UL10C and UBC7.2 (positive pressure) for a 1½-Hour Fire Listing for all 4'0" x 10'0" and 8'0" x 10'0" door and frame assemblies. Fire listing certifications apply to all approved hollow metal and wood door assemblies in drywall or masonry wall construction
- Special FirePins™ are only required on 3-Hour assemblies. Please refer to page 95 for illustrations and information regarding the application of Pemko FirePins™

- All hinges are supplied with standard fastener kits. Replacement kits/individual fasteners may be purchased separately
- Particle Board/TORX fasteners may be purchased separately. Full-mortise hinges require 40 each; half-surface hinges require 20 each; full-surface hinges require 12 each
- All half-surface and full-surface hinges are supplied with a snap cover for the door leaf. Replacement snap covers may be purchased separately

ELECTRICALLY MODIFIED CONTINUOUS GEARED HINGES

Electrical Modifications

- Pemko has vastly improved the cycle performance of the electrically modified hinge. Performance testing has shown that 3,000,000+ cycles can now be achieved using Pemko's exclusive polyurethane-coated 4, 8, or 12 TRI-FLEX titanium copper alloy cables. Each cable is capable of carrying 6 amps continuous or 16 amps in-rush @ 24-volts for 820 milliseconds. When ordering, please use the "shorthand code" shown in the chart page 82. For example, if you require a Clear Anodized standard Full-Mortise hinge at 83" with Quick Connect transfer - 4-wire, modified 36 1/4" from the top, right hand, you would order a CFM83 with QC4 at 36 1/4" from top - RH

Options for Electrically Modified Continuous Geared Hinges

These options allow variable degrees of service to be performed at the specific locations of the current carrying cables by installing a serviceable/removable hinge which includes a removable module (SER), or installing a hinge with a pivoting accessible feature (ACC).

- Both options (SER & ACC) are available in 4 Wire (QC4), 8 Wire (QC8), 12 Wire (QC12) variants
- Available on FM, FS, HS, KFM, SLF, SLI, XF, XI, XK, XM, X25M Models

Serviceable/Removable (SER) Module

The hinge is furnished to be installed in three sections allowing the current carrying cable to be serviced or replaced without removing the door from the frame. Additionally, the SER option allows the current carrying cables to be safely stored or delivered to the electrician or security contractor prior to the installation of the electrified hardware, eliminating the necessity of the electrician or security contractor being present when the doors are being hung.

Product Numbering Example: CFM83HD1xSER4

Accessible (ACC) Feature

The hinge is furnished to be installed in a single section with the leaves modified to pivot at the location of the current carrying cable and allow access to the cables and connected wiring.

Product Numbering Example: CFM83HD1xACC4

Concealed Magnetic Monitoring (CM)

Concealed magnetic monitoring is also available with the SER and ACC options. Magnetic monitor is supplied with monitor and an adjustable magnet.

Product Numbering Example: CFM83HD1xSER4xCM
CFM83HD1xACC4xCM

Customer Information Needed:

- Specify handing and prep location

Included:

- HD1, 1100 and X-Series model hinges using Molex connectors with ElectroLynx® are warranted for five (5) years. Standard duty and HD3 hinges are warranted for one (1) year

ElectroLynx®

As part of their promise to provide innovative, fast and effective high security solutions to their customers, certain ASSA ABLOY Group brands offer ElectroLynx®, a universal quick-connect system that simplifies the electrification of the door opening. ElectroLynx® is a registered trademark of ASSA ABLOY Inc.

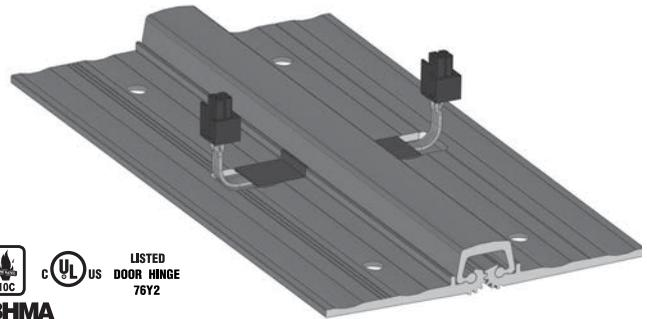

Quick Connect Transfer For Full Mortise (FM) Hinges	QC4 4 WIRE	Quick Connect Transfer For Full Surface (FS) & Half Surface (HS) Hinges	QC4_S 4 WIRE
	QC8 8 WIRE		QC8_S 8 WIRE
	QC12 12 WIRE		QC12_S 12 WIRE

Additional Electrical Modifications Options Code	
Additional Length of Quick Connect Cable Leads	
Adjustable Concealed Magnetic Monitoring	CM
Power Transfer - Prep Only	PT



Experience a safer and more open world

800-824-3018 | www.pemko.com
Check the web site for the up-to-date catalog

Copyright © 2015-2024, ASSA ABLOY Accessories and Door Controls Group, Inc., an ASSA ABLOY Group company. All rights reserved. Reproduction in whole or in part without the express written permission of ASSA ABLOY Accessories and Door Controls Group, Inc. is prohibited.

X-SERIES HINGES

- Thicker leaves than traditional continuous geared hinge and requires no additional clearance
- X-Series Hinges are HD1 Grade as standard
- X-Series hinges allow for a deeper cavity for electrical wires when ordering an electrified hinge

Full Mortise

XM_

STANDARD FINISHES: **BSP, C, D, SN, WSP, 10BE**

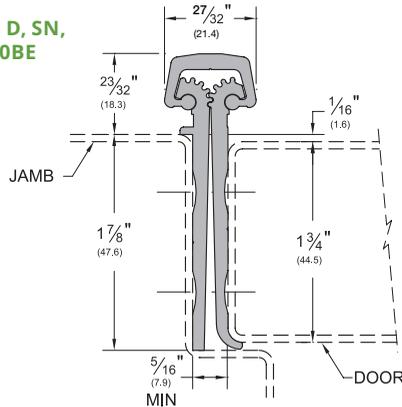

Full Mortise for 2 1/2" Thick Door

- Wider hinge leaves to accommodate doors 2 1/2" thick

X25M_

STANDARD FINISHES: **BSP, C, D, SN, WSP, 10BE**

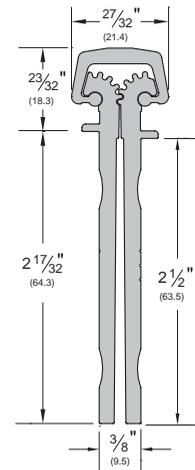

Short Leaf Flush

XF_

STANDARD FINISHES: **BSP, C, D, SN, WSP, 10BE**

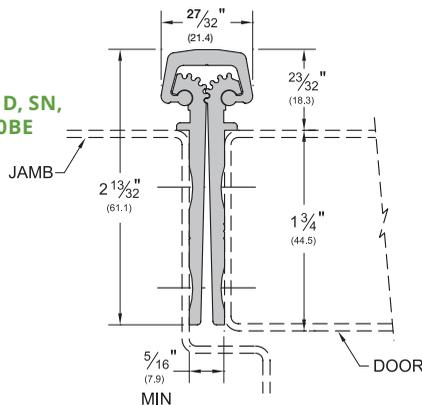

Kawneer Full Mortise

XK_

STANDARD FINISHES: **BSP, C, D, SN, WSP, 10BE**

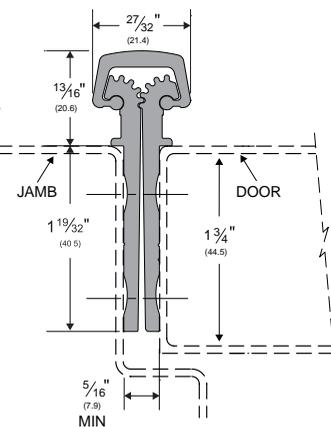

Short Leaf Inset

- Designed for use with hollow metal doors where the inset conforms to S.D.I. specifications for aligning doors and frames

XI_

STANDARD FINISHES: **BSP, C, D, SN, WSP, 10BE**

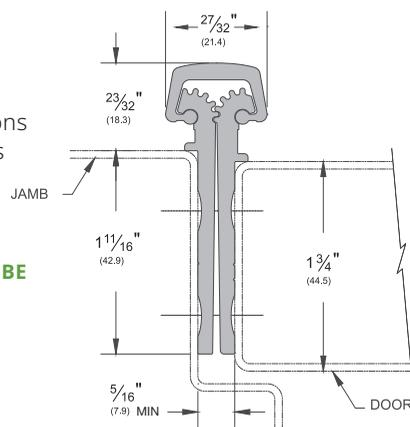

AVAILABLE FINISHES FOR PRODUCTS SHOWN ON THIS PAGE

10BE (Satin Bronze Powder Coated Aluminum) **BSP** (Black Suede Powder Coated Aluminum) **C** (Clear Anodized) **D** (Dark Bronze Anodized) **SN** (Satin Nickel Powder Coated Aluminum) **WSP** (White Suede Powder Coated Aluminum)

800-824-3018 | www.pemko.com

Check the web site for the up-to-date catalog

Copyright © 2015-2024, ASSA ABLOY Accessories and Door Controls Group, Inc., an ASSA ABLOY Group company. All rights reserved. Reproduction in whole or in part without the express written permission of ASSA ABLOY Accessories and Door Controls Group, Inc. is prohibited.



Experience a safer and more open world

OFFSET HINGES

- Used when extra clearance is needed when the door is open at 90°

Offset Full Mortise

_OS_FM

STANDARD FINISHES: **C, D**

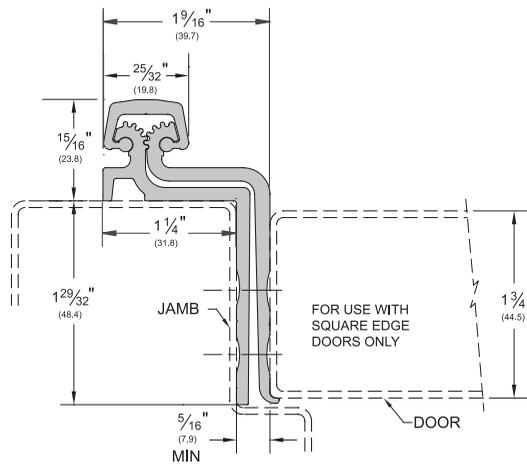

Offset Half Surface

- Replacement snap cover is C1 for Clear Anodized or D1 for Dark Bronze Anodized

_OS_HS

STANDARD FINISHES: **C, D**

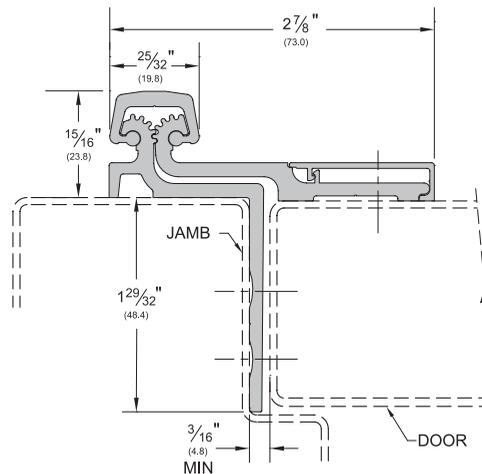

AVAILABLE FINISHES FOR PRODUCTS SHOWN ON THIS PAGE
C (Clear Anodized) **D** (Dark Bronze Anodized)



Experience a safer and more open world

800-824-3018 | www.pemko.com
 Check the web site for the up-to-date catalog

Copyright © 2015-2024, ASSA ABLOY Accessories and Door Controls Group, Inc., an ASSA ABLOY Group company. All rights reserved. Reproduction in whole or in part without the express written permission of ASSA ABLOY Accessories and Door Controls Group, Inc. is prohibited.

FULL MORTISE HINGES

- Full-Mortise units are designed mainly for new door applications and are applied to the frame rabbet and door edge to conceal both leaves

Full Mortise

_FM

STANDARD FINISHES: **BSP, C, D, SN, WSP, 10BE**



Evaluated in accordance with TAS201-94, TAS202-94, TAS203-94, ASTM E330, ASTM E1886, ASTM E1996, and ANSI A250.13 (includes PemKonnnect version)

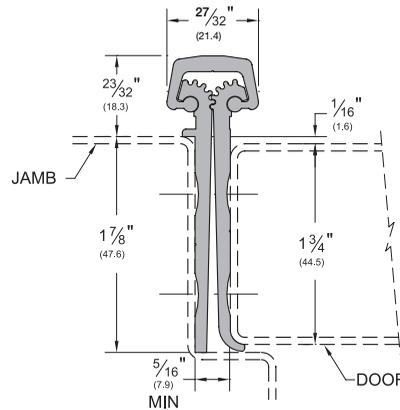

Modular Hinge Option

- Hinge is provided in 2 or 3 segments depending on length
- Hinges are packed in a shorter box and are easier to ship, transport, and store than traditional continuous hinges
- Available for select models, see price book for model availability

Full Mortise Short Leaf Inset

- Designed for use with doors which range between 1 3/4" to 2 1/4"
- Designed for use with hollow metal doors and frames where the inset conforms to S.D.I. specifications for aligning doors and frames

_FM_SLI

STANDARD FINISHES: **BSP, C, D, SN, WSP, 10BE**

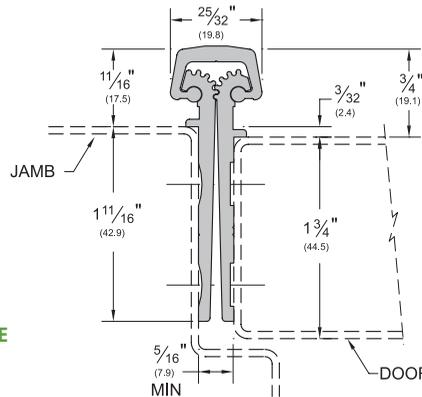

Evaluated in accordance with TAS201-94, TAS202-94, TAS203-94, ASTM E330, ASTM E1886, ASTM E1996, and ANSI A250.13

Full Mortise Short Leaf Flush

- Designed for use with doors which range between 1 3/4" to 2 1/4"
- Also used for bifold applications to keep the faces of the doors flush (not illustrated)

_FM_SLF

STANDARD FINISHES: **BSP, C, D, SN, WSP, 10BE**



Evaluated in accordance with TAS201-94, TAS202-94, TAS203-94, ASTM E330, ASTM E1886, ASTM E1996, and ANSI A250.13 (includes PemKonnnect version)

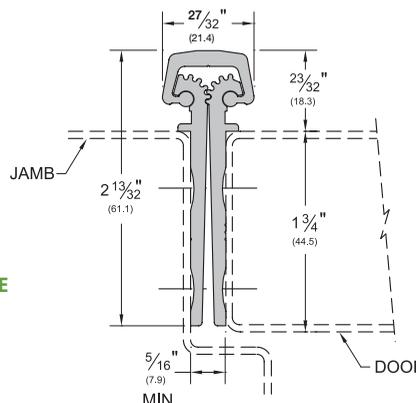

Modular Hinge Option

- Hinge is provided in 2 or 3 segments depending on length
- Hinges are packed in a shorter box and are easier to ship, transport, and store than traditional continuous hinges
- Available for select models, see price book for model availability

AVAILABLE FINISHES FOR PRODUCTS SHOWN ON THIS PAGE

10BE (Satin Bronze Powder Coated Aluminum) **BSP** (Black Suede Powder Coated Aluminum) **C** (Clear Anodized) **D** (Dark Bronze Anodized) **SN** (Satin Nickel Powder Coated Aluminum) **WSP** (White Suede Powder Coated Aluminum)

800-824-3018 | www.pemko.com

Check the web site for the up-to-date catalog

Copyright © 2015-2024, ASSA ABLOY Accessories and Door Controls Group, Inc., an ASSA ABLOY Group company. All rights reserved. Reproduction in whole or in part without the express written permission of ASSA ABLOY Accessories and Door Controls Group, Inc. is prohibited.



Experience a safer and more open world

SPECIAL FULL MORTISE HINGES

- Special Full-Mortise units are designed for door and frame applications where the hinge leaf may interfere with the weatherstrip, thermal break, or applied stop of the frame
- Special Full-Mortise hinges are applied to the frame rabbet and door edge to conceal both leaves

Special Full Mortise

_SPFM

STANDARD FINISHES: **BSP, C, D, SN, WSP, 10BE**

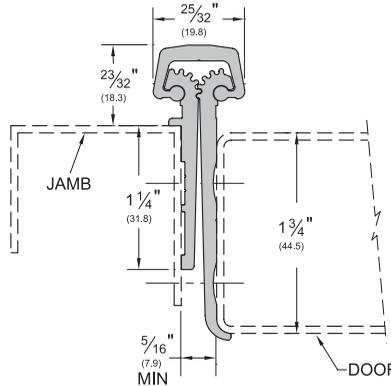

Special Full Mortise Short Leaf Inset

_SPFM_SLI

STANDARD FINISHES: **BSP, C, D, SN, WSP, 10BE**

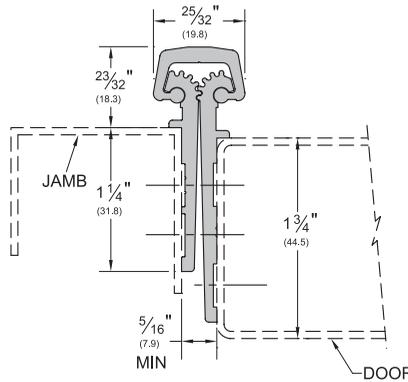

Special Full Mortise Short Leaf Flush

_SPFM_SLF

STANDARD FINISHES: **BSP, C, D, SN, WSP, 10BE**

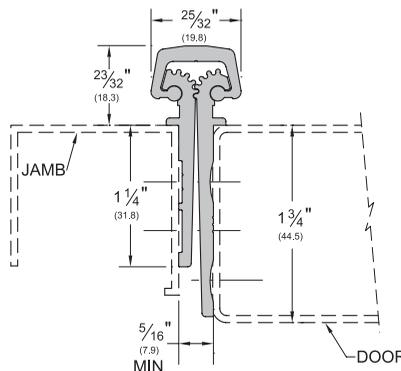

AVAILABLE FINISHES FOR PRODUCTS SHOWN ON THIS PAGE

10BE (Satin Bronze Powder Coated Aluminum) **BSP** (Black Suede Powder Coated Aluminum) **C** (Clear Anodized) **D** (Dark Bronze Anodized) **SN** (Satin Nickel Powder Coated Aluminum) **WSP** (White Suede Powder Coated Aluminum)



Experience a safer and more open world

800-824-3018 | www.pemko.com
Check the web site for the up-to-date catalog

Copyright © 2015-2024, ASSA ABLOY Accessories and Door Controls Group, Inc., an ASSA ABLOY Group company. All rights reserved. Reproduction in whole or in part without the express written permission of ASSA ABLOY Accessories and Door Controls Group, Inc. is prohibited.

FULL MORTISE HINGE

- Like our other Full Mortise units, the Kawneer Hinges are designed mainly for new door applications and are applied to the frame rabbet and door edge to conceal both leaves
- Developed for the Kawneer "Tuffline" series of aluminum doors

Kawneer Full Mortise

K_FM

STANDARD FINISHES: **BSP, C, D, SN, WSP, 10BE**

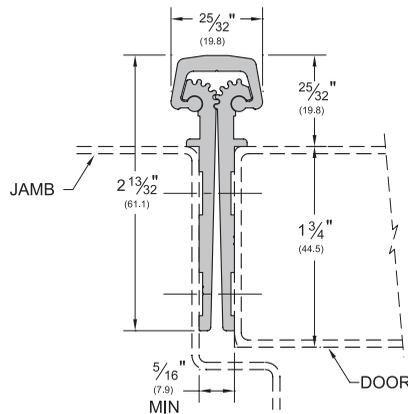

Raised Gear Hinge

- Designed for wood or metal cased openings when hinge is to be installed deep on the rabbet. The design of the leaves allows for the hinge to pivot without interference from the cap.
- Certain door/frame conditions may require an extra 1/32" to 1/16" clearance. Excessive clearance on fire rated assemblies may violate the requirements of NFPA80
- Heavy duty version available only

Full Mortise Raised Gear

_FM_RG

STANDARD FINISHES: **BSP, C, D, SN, WSP, 10BE**

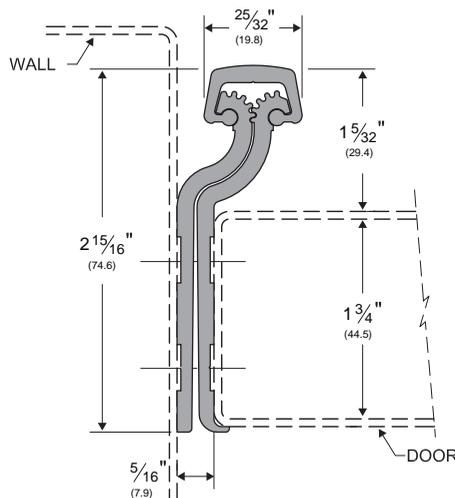

AVAILABLE FINISHES FOR PRODUCTS SHOWN ON THIS PAGE

10BE (Satin Bronze Powder Coated Aluminum) **BSP** (Black Suede Powder Coated Aluminum) **C** (Clear Anodized)
D (Dark Bronze Anodized) **SN** (Satin Nickel Powder Coated Aluminum) **WSP** (White Suede Powder Coated Aluminum)

800-824-3018 | www.pemko.com

Check the web site for the up-to-date catalog

Copyright © 2015-2024, ASSA ABLOY Accessories and Door Controls Group, Inc., an ASSA ABLOY Group company. All rights reserved.
 Reproduction in whole or in part without the express written permission of ASSA ABLOY Accessories and Door Controls Group, Inc. is prohibited.



Experience a safer
and more open world

FULL MORTISE SAFETY HINGE

- Full Mortise Safety units are designed mainly for new door applications in child care and nursing facilities
- These hinges require extra clearance and are applied to conceal both leaves

Full Mortise Safety

_FM_SF

STANDARD FINISHES: **BSP, C, D, SN, WSP, 10BE**

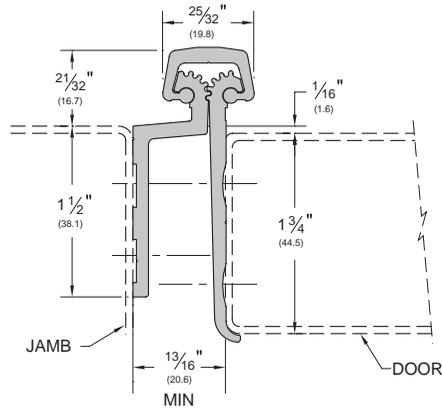

Full Mortise Short Leaf Inset Safety

_FM_SLISF

STANDARD FINISHES: **BSP, C, D, SN, WSP, 10BE**

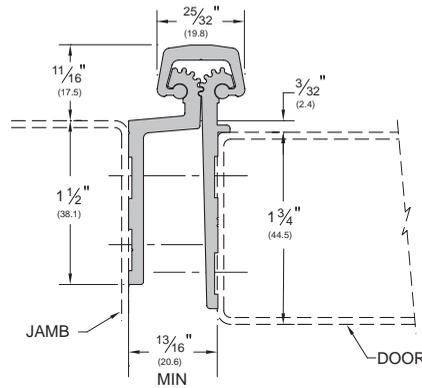

Full Mortise Hinge for 1 3/8" Door

- More bearings than _RS138 hinge to work in commercial grade application
- Shorter leaves for thinner doors

Full Mortise

FM_SLF138

STANDARD FINISHES: **BSP, C, D, SN, WSP, 10BE**



LISTED
DOOR HINGE
76Y2

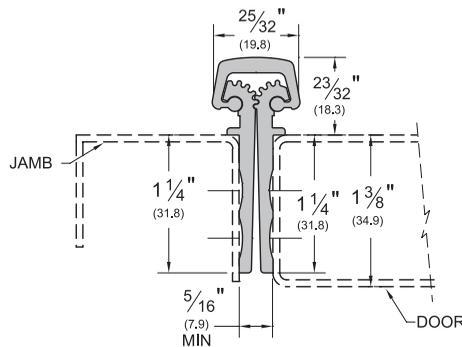

AVAILABLE FINISHES FOR PRODUCTS SHOWN ON THIS PAGE

10BE (Satin Bronze Powder Coated Aluminum) **BSP** (Black Suede Powder Coated Aluminum) **C** (Clear Anodized)
D (Dark Bronze Anodized) **SN** (Satin Nickel Powder Coated Aluminum) **WSP** (White Suede Powder Coated Aluminum)



Experience a safer
and more open world

800-824-3018 | www.pemko.com
Check the web site for the up-to-date catalog

Copyright © 2015-2024, ASSA ABLOY Accessories and Door Controls Group, Inc., an ASSA ABLOY Group company. All rights reserved. Reproduction in whole or in part without the express written permission of ASSA ABLOY Accessories and Door Controls Group, Inc. is prohibited.

WIDE THROW FULL MORTISE HINGE

- Wide Throw Full Mortise units are designed mainly for new door applications that require extra clearance due to special frame, door or wall design, and are applied to the frame rabbet and door edge to conceal both leaves
- More clearance between the door and frame when door is open 180°
- Available only in heavy duty to support larger doors

Wide Throw Full Mortise

WT_FM

STANDARD FINISHES: **BSP, C, D, SN, WSP, 10BE**

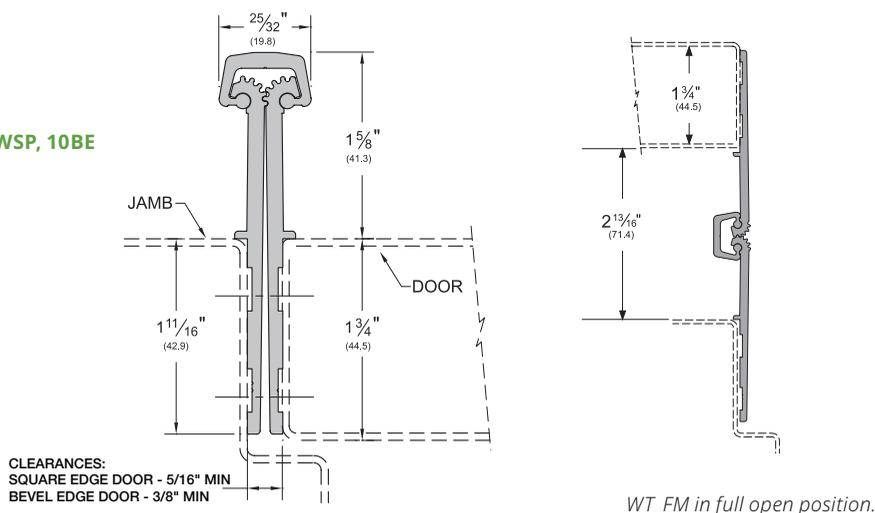

WIDE THROW HALF SURFACE HINGE

- Wide Throw Half Surface units are designed mainly for retrofit applications that require extra clearance due to special frame, door, or wall design and are applied to the frame rabbet and the exposed door surface
- Wide Throw Half Surface units combine the versatility of the Half Surface unit and the clearance of a Wide Throw hinge into one
- Replacement snap cover is C1 for Clear Anodized or D1 for Dark Bronze Anodized

Wide Throw Half Surface

WT_HS

STANDARD FINISHES: **C, D**

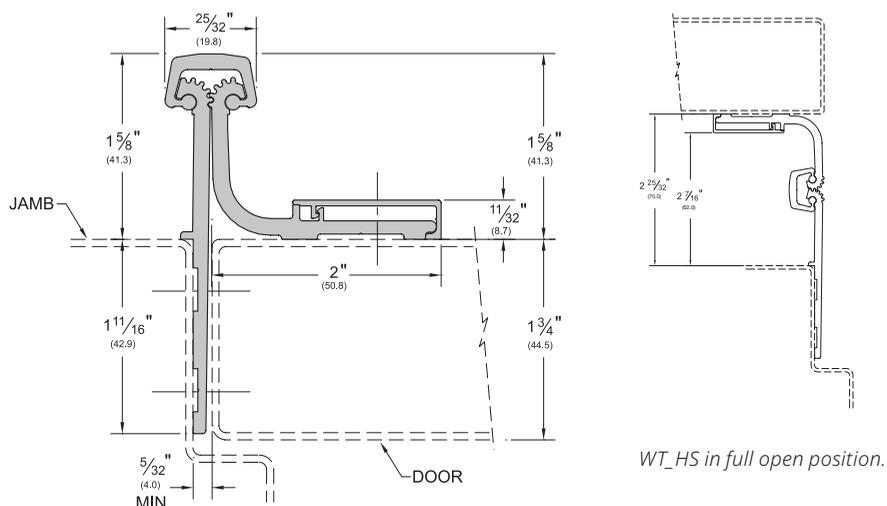

AVAILABLE FINISHES FOR PRODUCTS SHOWN ON THIS PAGE AS INDICATED BY PROFILE (see General Information section for finish chart)

10BE (Satin Bronze Powder Coated Aluminum) **BSP** (Black Suede Powder Coated Aluminum) **C** (Clear Anodized) **D** (Dark Bronze Anodized) **SN** (Satin Nickel Powder Coated Aluminum) **WSP** (White Suede Powder Coated Aluminum)

800-824-3018 | www.pemko.com

Check the web site for the up-to-date catalog

Copyright © 2015-2024, ASSA ABLOY Accessories and Door Controls Group, Inc., an ASSA ABLOY Group company. All rights reserved. Reproduction in whole or in part without the express written permission of ASSA ABLOY Accessories and Door Controls Group, Inc. is prohibited.

PEMKO
ASSA ABLOY

Experience a safer
and more open world

HALF SURFACE HINGE

- Half Surface units are designed mainly for retrofit work, and are applied to the exposed surface of the door and the frame rabbet
- Designed for use with hollow metal frames, where the inset conforms to S.D.I. specifications for aligning doors and frames

- Allows for adjustments in order to properly align edge of the door to the frame
- Replacement snap cover is C1 for Clear Anodized or D1 for Dark Bronze Anodized

Half Surface

_HS

STANDARD FINISHES: **C, D**

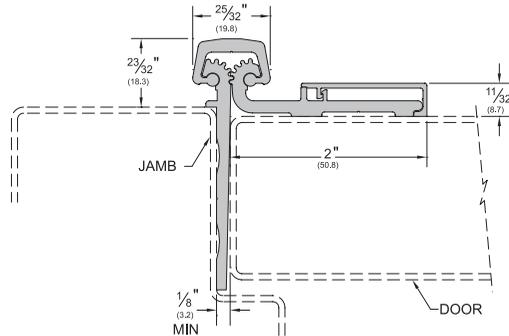

HALF SURFACE SAFETY HINGE

- Half Surface Safety units are designed mainly for retrofit work in child care and nursing facilities and are applied to the exposed surface of the door and the frame rabbet

- Replacement snap cover is C1 for Clear Anodized or D1 for Dark Bronze Anodized

Half Surface Safety

_HS_SF

STANDARD FINISHES: **C, D**

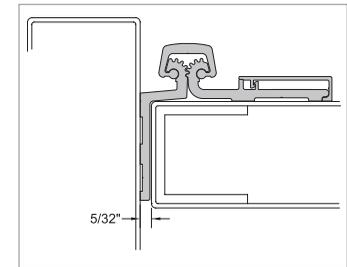
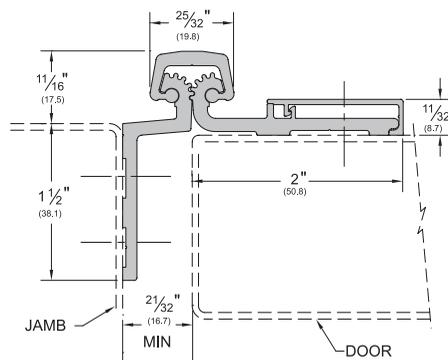

HS_SF in deep frame application is no longer a safety hinge

HALF MORTISE HINGE

- Half Mortise units are designed mainly for retrofit work and are applied to the exposed surface of the frame and the door edge
- Designed to require only 5/32" clearance instead of 5/16" and also allows for adjustments to properly align edge of the door to the frame face

- Replacement snap cover is C29316 for Clear Anodized or D29316 for Dark Bronze Anodized

Half Mortise

_HM

STANDARD FINISHES: **C, D**

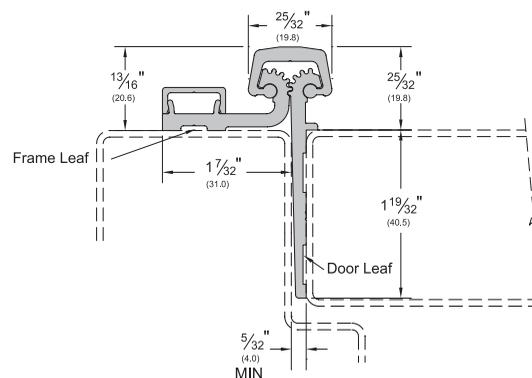

AVAILABLE FINISHES FOR PRODUCTS SHOWN ON THIS PAGE
C (Clear Anodized) **D** (Dark Bronze Anodized)



Experience a safer and more open world

800-824-3018 | www.pemko.com
 Check the web site for the up-to-date catalog

Copyright © 2015-2024, ASSA ABLOY Accessories and Door Controls Group, Inc., an ASSA ABLOY Group company. All rights reserved. Reproduction in whole or in part without the express written permission of ASSA ABLOY Accessories and Door Controls Group, Inc. is prohibited.

STANDARD FULL SURFACE HINGE

- Full Surface units are designed mainly for retrofit work, and are applied to the exposed surfaces of the door and frame
- Replacement snap cover is C1 for Clear Anodized or D1 for Dark Bronze Anodized

Full Surface

_FS

STANDARD FINISHES: **C, D**



Evaluated in accordance with TAS201-94, TAS202-94, TAS203-94, ASTM E330, ASTM E1886, ASTM E1996, and ANSI A250.13 (PemKconnect version only)

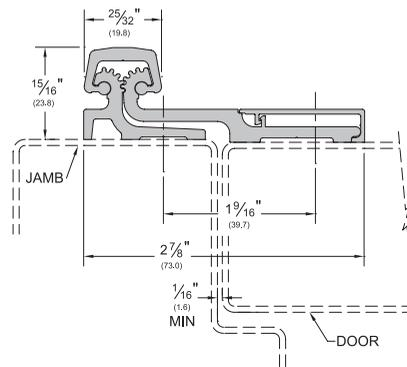

Modular Hinge Option

- Hinge is provided in 2 or 3 segments depending on length
- Hinges are packed in a shorter box and are easier to ship, transport, and store than traditional continuous hinges
- Available for select models, see price book for model availability

FULL SURFACE CENTER PIVOT HINGE

- Full Surface Center Pivot units are designed mainly for retrofit work and are applied to the exposed surfaces of the door and frame
- Full Surface Center Pivot units easily replace butt hinges since no door or frame adjustments are necessary and are more versatile with restricted frame faces
- Replacement snap cover for door leaf is C1 for Clear Anodized or D1 for Dark Bronze Anodized. Replacement snap cover for frame leaf is C29316 for Clear Anodized or D29316 for Dark Bronze Anodized

Full Surface Center Pivot

_FS_CP

STANDARD FINISHES: **C, D**

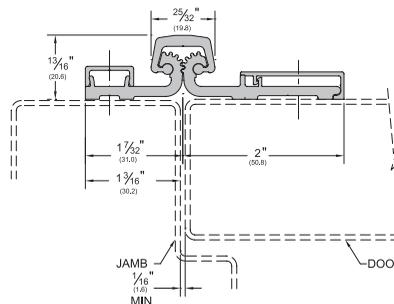

Modular Hinge Option

- Hinge is provided in 2 or 3 segments depending on length
- Hinges are packed in a shorter box and are easier to ship, transport, and store than traditional continuous hinges
- Available for select models, see price book for model availability

AVAILABLE FINISHES FOR PRODUCTS SHOWN ON THIS PAGE
C (Clear Anodized) **D** (Dark Bronze Anodized)

800-824-3018 | www.pemko.com

Check the web site for the up-to-date catalog

Copyright © 2015-2024, ASSA ABLOY Accessories and Door Controls Group, Inc., an ASSA ABLOY Group company. All rights reserved.
 Reproduction in whole or in part without the express written permission of ASSA ABLOY Accessories and Door Controls Group, Inc. is prohibited.

PEMKO
ASSA ABLOY

Experience a safer
 and more open world

FULL MORTISE RESIDENTIAL HINGES

- Full Mortise Residential units are designed mainly for new door and frame applications, and are applied to conceal both leaves

NOTE: All RS series hinges are excluded from the "LIFE OF THE OPENING" guarantee, and instead carry a ten (10) year warranty

_RS175

STANDARD FINISHES: **C, D**

- Designed for 1³/₄" MAXIMUM thickness with a weight up to 90 lbs.

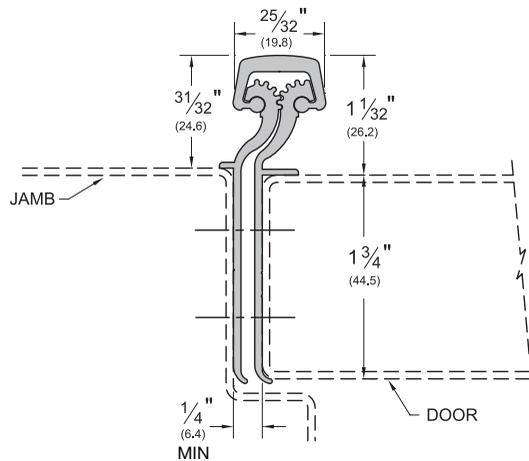

_RS138

STANDARD FINISHES: **C, D**

- Shorter leaves for thinner doors
- Designed for doors 1³/₈" thick with a weight limit up to 90 lbs.

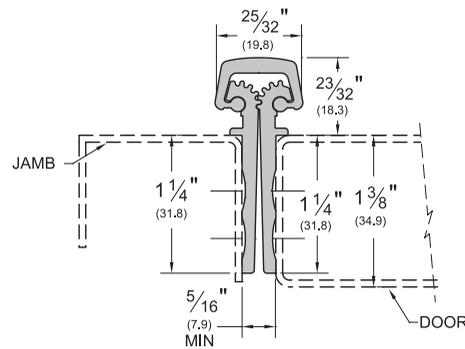

AVAILABLE FINISHES FOR PRODUCTS SHOWN ON THIS PAGE
C (Clear Anodized) **D** (Dark Bronze Anodized)

PEMKO
ASSA ABLOY

Experience a safer
 and more open world

800-824-3018 | www.pemko.com
 Check the web site for the up-to-date catalog

Copyright © 2015-2024, ASSA ABLOY Accessories and Door Controls Group, Inc., an ASSA ABLOY Group company. All rights reserved.
 Reproduction in whole or in part without the express written permission of ASSA ABLOY Accessories and Door Controls Group, Inc. is prohibited.

FIREPINS FOR USE WITH 3-HOUR FIRE RATED ASSEMBLIES

- FirePins™ are required to achieve 3-hour fire rating
- Although PemkoHinge® Continuous Hinges carry UL Fire Ratings unequalled in the industry, some applications may require the use of FirePins™
- FirePin™ applications fall within the UL guidelines for retro-fitting assemblies in the field. Expensive shop modifications and door/frame reinforcements are not required
- FirePins™ also add extra security to a door assembly

Full Mortise Hinges

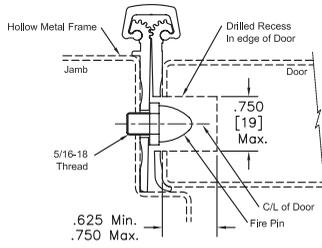

FirePin Locations

- The locations (illustrated right) indicate where holes should be drilled on the hinge edge of the door
- These locations are appropriate for all hinge models (Full Mortise, Full Surface, and Half Surface)

Full Surface Hinges

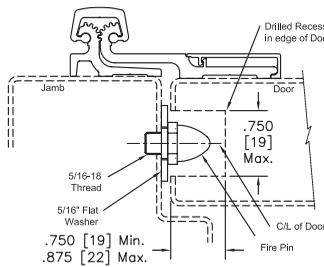

Half Surface Hinges

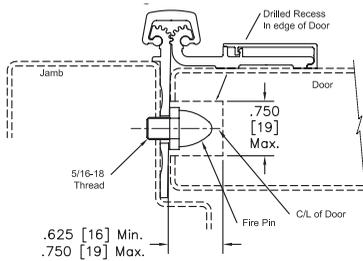

80" to 95" Hinges

96" to 120" Hinges

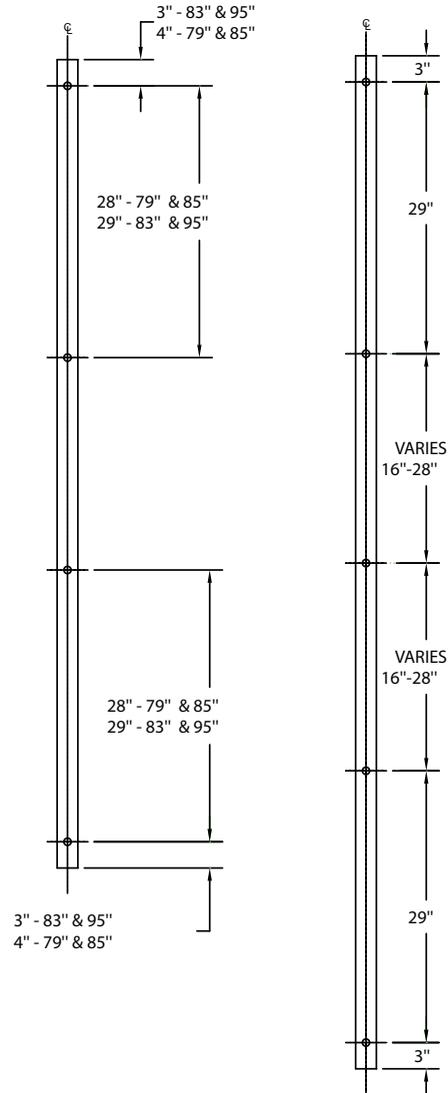

DOUBLE SWING HINGE AND EMERGENCY RELEASE STOP

- Innovative healthcare solution that permits quick door opening in an emergency situation
- Double Swing Hinge has a unique 100° swing and allows the door to swing in either direction
- Emergency Release Stop features a special flush bolt that is used to release the door in an emergency situation. Hospital tip is standard.

- The Pemko DSH1000 Pin & Barrel Double Swing Hinge is an option to use with the Emergency Release Stop to create an anti-barricade system.
- Order form required, available online.

Double Swing Hinge

- Meets the cycle test requirements for ANSI/BHMA A156.26 for Continuous Hinges.
- Meets the barrier free requirements of ICC/ANSI A117.1 and ADAAG (2010)

DSH_

AVAILABLE FINISHES: **C**

- Designed for 1³/₄" MAXIMUM thickness with a weight up to 250 lbs.

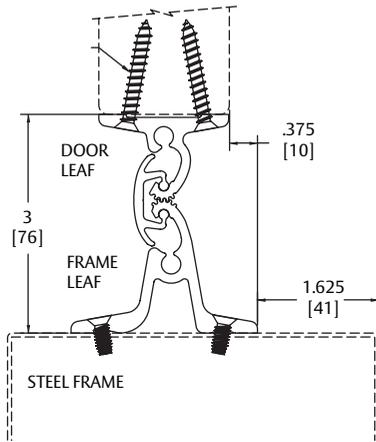

Hinge Size	Opening	Clear Anodized
84"	7' 0"	DSHP01C-84
96"	8' 0"	DSHP01C-96
120"	10' 0"	DSHP01C-120

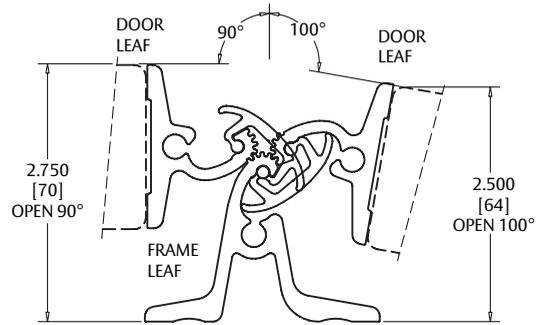

NOTE: DSH1000 Pin & Barrel Double Swing Hinge shown on page 95

Emergency Release Stop

- Minimum 2³/₄" backset for hardware trim
- NOTE: With 2³/₄" hardware trim backset, a Notch is required in the ERS to clear the hardware trim. The type of Notch is determined by the manufacturer based on the information provide on the order form.

- To avoid using an extended lip strike, use a single rabbet jamb on strike side of frame only with cased open header and hinge jamb.

ERS_

AVAILABLE FINISHES: **C**

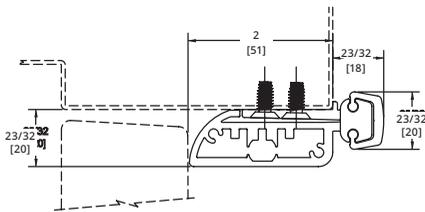

Hinge Size	Opening	Clear Anodized - Left Hand	Clear Anodized - Right Hand
84"	7' 0"	ERS84CxHT-LH	ERS84CxHT-RH
96"	8' 0"	ERS96CxHT-LH	ERS96CxHT-RH
120"	10' 0"	ERS120CxHT-LH	ERS120CxHT-RH

AVAILABLE FINISHES FOR PRODUCTS SHOWN ON THIS PAGE
C (Clear Anodized)



Experience a safer and more open world

800-824-3018 | www.pemko.com
Check the web site for the up-to-date catalog

Copyright © 2015-2024, ASSA ABLOY Accessories and Door Controls Group, Inc., an ASSA ABLOY Group company. All rights reserved. Reproduction in whole or in part without the express written permission of ASSA ABLOY Accessories and Door Controls Group, Inc. is prohibited.

PEMKO 1000 SERIES ALUMINUM PIN & BARREL CONTINUOUS HINGES

Short Form Architectural Specification:

Continuous hinges shall be full height piano-type hinge providing full height door support.

- Supports weights up to 600 lbs. 4'0" maximum door width
- Material to be extruded aluminum 6063-T6 alloy
- .250" diameter stainless pin (rod)
- Each knuckle 4", including nylon bearing at each separation for a quiet, smooth, self-lubricating operation
- Finish: Clear Anodized (628)
- All hinges shall be furnished with manufacturer's recommended hardware pack per specific model application
- Exterior barrel diameter .750" (3/4")
- Hinges certified ANSI/BHMA Standard A 156.26 Grade 1
- Symmetrically templated hole pattern

Note: 25-Year Warranty on all Continuous Pin & Barrel Hinges

PEMKO DSH1000 DOUBLE SWING HINGE

Standard Features

Barrel Type Hinge

.250" diameter stainless steel pin (rod)

Medical bearings

Material

6063-T6 aluminum alloy

Finishes

Clear Anodized (628)

Order form required, available online.

Standards

ANSI/BHMA Standard A156.26 Grade 1

Mounting Hardware

12-24 x 11/16" Torx Flat Head Undercut TEK Screws
#12-8 Torx Flat Head Particle Board Screw

Capacity

Supports weights up to 600lbs. 4'0" maximum door width

Standard Sizes

7'0", 8'0"

Hole Pattern

Symmetrically templated

Handing

Handing not required

CMS Compliant

Eliminating additional ligature points ensures compliance for reimbursement through CMS (Centers for Medicare and Medicaid Services)

This door edge mounted aluminum pin & barrel type hinge has a unique feature that allows the door to swing in either direction up to 100°. When used in conjunction with Pemko Emergency Release Stop (ERS) provides an anti-barricade system.

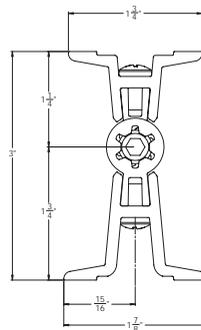

Door Closed

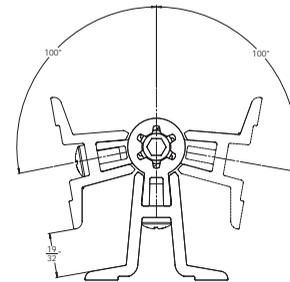

Door Open 100° Either Direction

800-824-3018 | www.pemko.com

Check the web site for the up-to-date catalog

Copyright © 2015-2024, ASSA ABLOY Accessories and Door Controls Group, Inc., an ASSA ABLOY Group company. All rights reserved. Reproduction in whole or in part without the express written permission of ASSA ABLOY Accessories and Door Controls Group, Inc. is prohibited.



Experience a safer and more open world

POWER TRANSFERS

- These Securitron electronic power transfer units fit into doors and frames to transfer power from your power supply to the door-mounted electronic device
- Contact your hinge manufacturer for cutout availability
- Order form required, available online

EL-CEPT

AVAILABLE COLORS:
US32D, US10B

- Mortises into the edges of the door and frame
- Tamper-resistant; no exposed openings
- All metal construction, including backboxes
- 7/8" knockouts on back boxes to accommodate EMF-type fitting
- 12-wire configuration with ElectroLynx compatible connectors
- Tested to 1,000,000 cycles
- Will not work on center-hung or balanced doors
- Works with most continuous hinges, up to 6" wide
- UL10B and UL10C listed

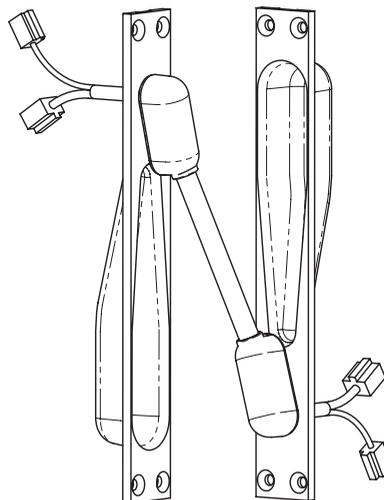

EL-EPT

AVAILABLE COLORS:
US2C

- Installs in the door and frame edges
- Flexible steel shield protects wires—3/8" (9.5mm) I.D.
- New universal device; works with most butt and continuous hinges
- Not for use with center pivot doors or with pivot hinges with offset greater than 3/4"
- UL634, UL10B, UL10C Listed
- ANSI A250.13-2003-Windstorm Resistant



EL-EPTL

AVAILABLE COLORS:
US2C

- Installs in the door and frame edges
- Flexible steel shield protects wires—3/8" (9.5mm) I.D.
- New universal device; works with most butt and continuous hinges
- Not for use with center pivot doors or with pivot hinges with offset greater than 3/4"
- UL634, UL10B, UL10C Listed
- ANSI A250.13-2003-Windstorm Resistant



EL-EPT-SC

AVAILABLE COLORS:
US2C

- Installs in the door and frame edges
- Flexible steel shield protects wires—3/8" (9.5mm) I.D.
- New universal device; works with most butt and continuous hinges
- Functions on off-set pivot and swing clear hinged doors
- UL634, UL10B, UL10C Listed
- ANSI A250.13-2003-Windstorm Resistant

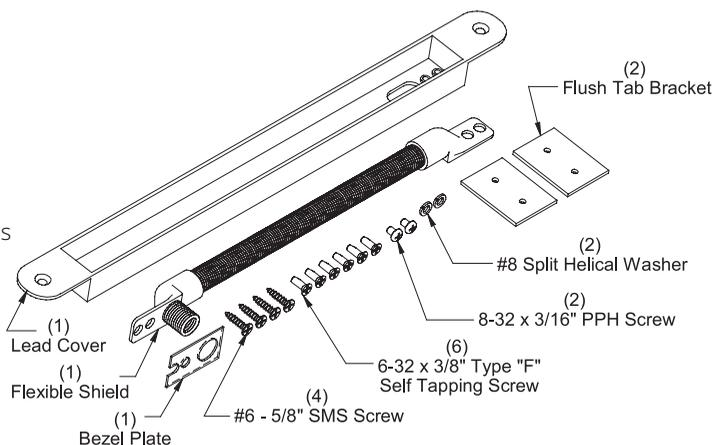

PEMKO
ASSA ABLOY

Experience a safer
and more open world

800-824-3018 | www.pemko.com
Check the web site for the up-to-date catalog

Copyright © 2015-2024, ASSA ABLOY Accessories and Door Controls Group, Inc., an ASSA ABLOY Group company. All rights reserved. Reproduction in whole or in part without the express written permission of ASSA ABLOY Accessories and Door Controls Group, Inc. is prohibited.

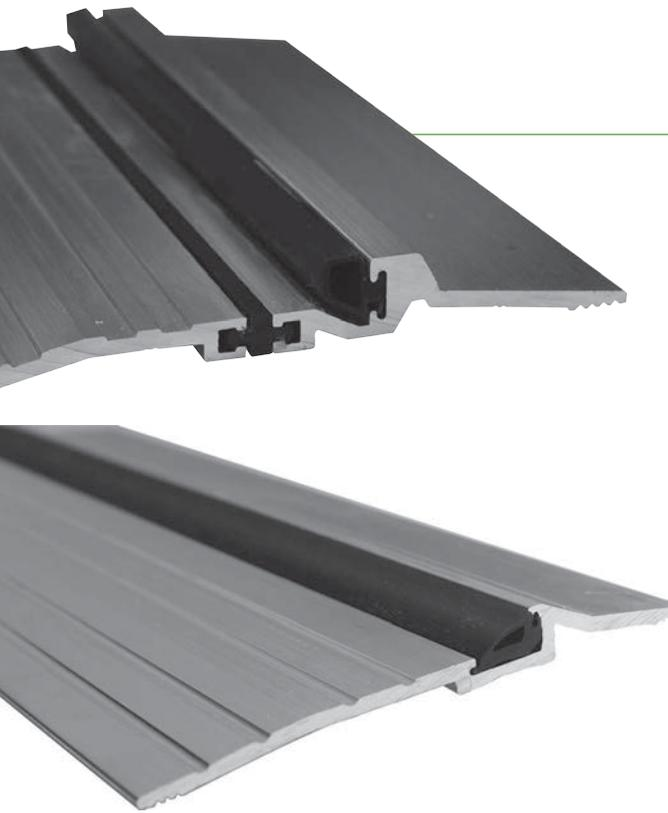

COMMERCIAL THRESHOLDS

CONTENTS:

Saddle Thresholds	84
Half Saddle Thresholds.....	89
Offset Saddles and Offset Half Saddles	91
Stainless Steel Saddles.....	92
Stainless Steel Half Saddles and Offset Saddles	92
Thermal Break Saddles	93
Stainless Steel Thermal Break Threshold	96
Latching Panic Exit Saddles	97
Latching Panic Exit Saddles - Thermal Break.....	101
Acoustic Thresholds	104
Threshold with Flexible Joint.....	104
Concealed Fastener Thresholds	105
Eco-V™ Thresholds.....	106
Adjustable-Width Eco-V™ Threshold.....	107
Heavy Duty Latching Panic Exit Saddle Threshold	108
Heavy Duty Thresholds.....	108
Modular Heavy Duty Thresholds	109
Floor Plates/Safety Treads.....	110
Aluminum Plates	111
Carpet Separators.....	112
Floor Plate Supports/Accessories and Elevators.....	113
Threshold Stop Strips.....	114
Floor Closer Thresholds/Cover Plate Assemblies	115
ANSI/BHMA A156.21 Thresholds - Cross Reference	116

INDEX:

PRODUCT	PAGE	PRODUCT	PAGE	PRODUCT	PAGE	PRODUCT	PAGE	PRODUCT	PAGE
14/1	111	195.....	113	254x226_FG.....	101	279x224_FG.....	102	2548.....	87
18/1	111	196.....	113	255	90	279x292_FGPK.....	103	2548.....	115
151	84	200	113	255x5.....	88	282	113	2548x170.....	115
154.....	86	227	110	255x5_FG.....	94	283	113	2548x171	115
154SS.....	92	228	110	255x 226	100	290	114	2549.....	88
157.....	91	229	110	255x226_FG.....	101	566	91	2550.....	88
158.....	91	230	112	256	90	566x3_FG	95	2555.....	90
158SS.....	92	236	112	256x6.....	88	573x5_FG	104	2565.....	90
159.....	99	252	90	256x6_FG.....	93	650	105	2705.....	108
166.....	86	252SS.....	92	257x259	115	651.....	105	2715	108
169.....	86	252x2_FG	94	270.....	84	671.....	105	2716	108
170.....	86	252x2SSFG.....	96	271.....	84	766	91	2727	91
171.....	87	252x3_FG	94	272	84	766x3_FG.....	95	2746	89
172.....	87	252x3SSFG.....	96	273	89	1547	86	2746x6.....	85
173.....	84	252x4SSFG.....	96	273x3_FG.....	93	1710.....	87	2746x6_FG	93
174.....	112	252x226	100	273x4_FG.....	93	1715.....	108	2746x292_FGPK.....	103
175.....	86	252x226_FG.....	101	273x224_FG.....	102	1716.....	109	2748	85
175SS.....	92	253	90	273x292_FGPK.....	103	1717.....	109	2748	115
176.....	87	253SS.....	92	274.....	89	1718.....	109	2748x270.....	115
176.....	115	253x3_FG	94	274x4	85	1719.....	109	2748x271	115
176x170.....	115	253x3SS FG.....	96	274x4_FG.....	93	1842	114	2749	85
176x171	115	253x4_FG	94	274x4x270	115	1855	99	2750	85
177.....	99	253x4SS FG	96	274x4x271	115	1951.....	112	2755	89
179.....	98	253x6_FG	95	274x224_FG	102	2001	97	19125	111
181.....	99	253x226_FG.....	101	274x292_FGPK.....	103	2002	97	ADJ232V8.....	107
182.....	91	254	90	276.....	85	2005	97	ADJ232V14.....	107
183.....	113	254SS.....	92	276.....	115	2006.....	97	ADJ232x2325V8.....	107
184.....	114	254x4.....	88	276x270	115	2006STC.....	104	EV232	106
185.....	100	254x4_FG.....	95	276x271	115	2008.....	104	EV2320	106
190.....	110	254x4SS FG.....	96	277	98	2009.....	98	EV2322.....	106
191.....	110	254x4x170.....	115	278.....	89	2010.....	98	EV2325	106
192.....	110	254x4x171	115	278x224_FG.....	102	2266.....	110	EV2326	106
193.....	110	254x5_FG	95	278x292_FGPK.....	103	2286.....	110		
193x2/195.....	115	254x226	100	279.....	89	2364.....	112		

800-824-3018 | www.pemko.com

Check the web site for the up-to-date catalog

Copyright © 2015-2024, ASSA ABLOY Accessories and Door Controls Group, Inc., an ASSA ABLOY Group company. All rights reserved.
 Reproduction in whole or in part without the express written permission of ASSA ABLOY Accessories and Door Controls Group, Inc. is prohibited.



Experience a safer
and more open world

SADDLE THRESHOLDS

- To use a saddle threshold in an offset condition, use an elevator (see page 131)

173_

AVAILABLE FINISHES: **10BE, A, BSP, D, WSP**
ANSI (aluminum): **J32300, J32330**

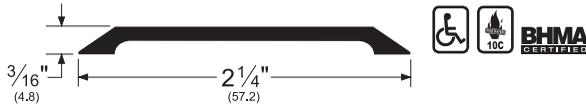

151_

AVAILABLE FINISHES: **10BE, A, BSP, D, WSP**
ANSI (aluminum): **J32300, J32330**

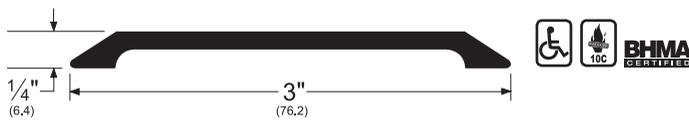

270_

AVAILABLE FINISHES: **10BE, A, B, BSP, D, G, WSP**
ANSI (aluminum): **J32100, J32130**
ANSI (brass): **J12300, J12330**



271_

AVAILABLE FINISHES: **10BE, A, B, BSP, D, G, SN, WSP**
ANSI (aluminum): **J32100, J32130**
ANSI (brass): **J12100, J12130**

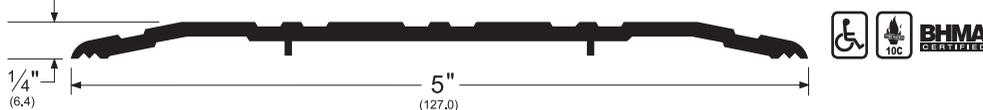

272_

AVAILABLE FINISHES: **10BE, A, B, BSP, D, G, WSP**
ANSI (aluminum): **J32100, J32130**
ANSI (brass): **J12100, J12130**



NOTE: Products shown in this section may not be drawn to scale.

AVAILABLE FINISHES FOR PRODUCTS SHOWN ON THIS PAGE

10BE (Satin Bronze Powder Coated Aluminum) **A** (Mill Finish Aluminum) **B** (Mill Finish Extruded Bronze [Brass])
BSP (Black Suede Powder Coated Aluminum) **D** (Dark Bronze Anodized) **G** (Gold Anodized)
SN (Satin Nickel Anodized) **WSP** (White Suede Powder Coated Aluminum)

NOTE: **G, SN** are available with limited inventory



Experience a safer
and more open world

800-824-3018 | www.pemko.com
Check the web site for the up-to-date catalog

Copyright © 2015-2024, ASSA ABLOY Accessories and Door Controls Group, Inc., an ASSA ABLOY Group company. All rights reserved.
Reproduction in whole or in part without the express written permission of ASSA ABLOY Accessories and Door Controls Group, Inc. is prohibited.

SADDLE THRESHOLDS (Cont.)

276_

AVAILABLE FINISHES: **10BE, A, BSP, D, WSP**
 ANSI (aluminum): **J32100, J32130, J39100, J39130, J39135, J39150**

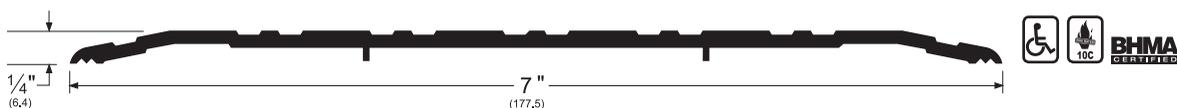

2748_

AVAILABLE FINISHES: **10BE, A, BSP, D, WSP**
 ANSI (aluminum): **J32100, J32130, J39100, J39130, J39135, J39150**

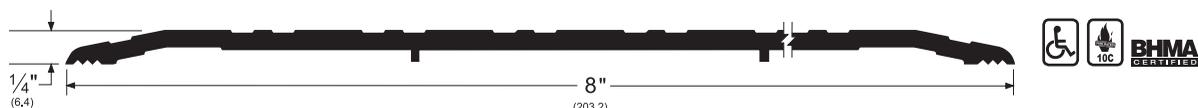

274x4_

AVAILABLE FINISH: **B**
 ANSI (brass): **J12100, J12130, J19100, J19130, J19135, J19150**

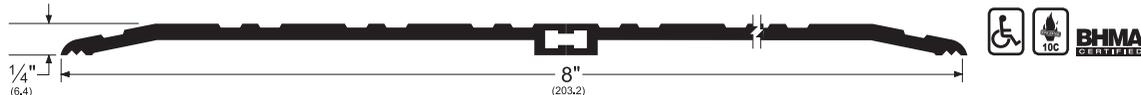

Welded on bottom.

2746x6_

AVAILABLE FINISHES: **10BE, A, BSP, D, WSP**
 ANSI (aluminum): **J32100, J32130**

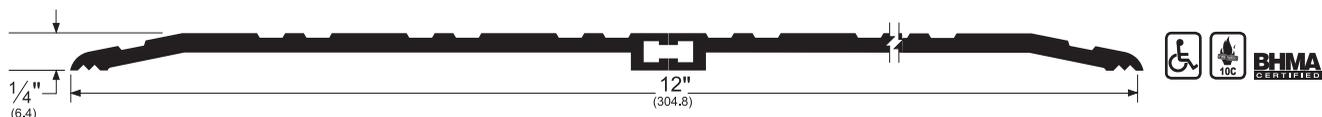

Welded on bottom.

2749_

AVAILABLE FINISHES: **10BE, A, BSP, D, WSP**
 ANSI (aluminum): **J32100, J32130**



2750_

AVAILABLE FINISHES: **10BE, A, BSP, D, WSP**
 ANSI (aluminum): **J32100, J32130**

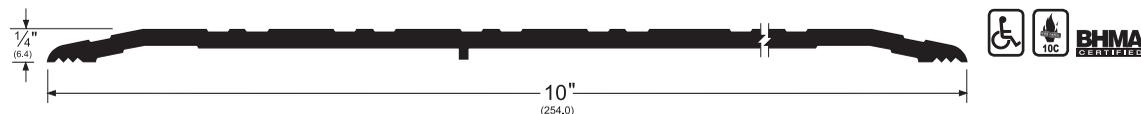

Includes two support legs (only one shown due to break in drawing)

NOTE: Products shown in this section may not be drawn to scale.

AVAILABLE FINISHES FOR PRODUCTS SHOWN ON THIS PAGE

10BE (Satin Bronze Powder Coated Aluminum) **A** (Mill Finish Aluminum) **B** (Mill Finish Extruded Bronze [Brass])
BSP (Black Suede Powder Coated Aluminum) **D** (Dark Bronze Anodized) **WSP** (White Suede Powder Coated Aluminum)

800-824-3018 | www.pemko.com

Check the web site for the up-to-date catalog

Copyright © 2015-2024, ASSA ABLOY Accessories and Door Controls Group, Inc., an ASSA ABLOY Group company. All rights reserved.
 Reproduction in whole or in part without the express written permission of ASSA ABLOY Accessories and Door Controls Group, Inc. is prohibited.

PEMKO
ASSA ABLOY

Experience a safer
 and more open world

SADDLE THRESHOLDS (Cont.)

169_

AVAILABLE FINISHES: **10BE, A, BSP, D, WSP**
ANSI (aluminum): **J32100, J32130**

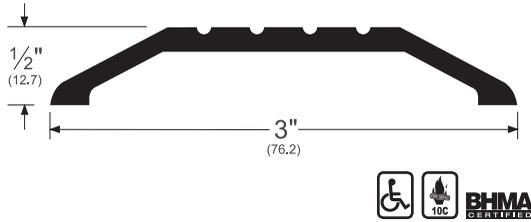

166_

AVAILABLE FINISHES: **10BE, A, BSP, D, WSP**
ANSI (aluminum): **J32100, J32130**

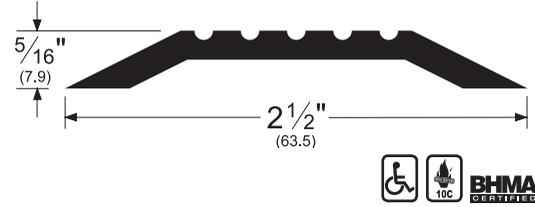

170_

AVAILABLE FINISHES: **10BE, A, B, BDG, BSP, D, WSP**
ANSI (aluminum): **J32100, J32130**
ANSI (brass): **J12100, J12130**

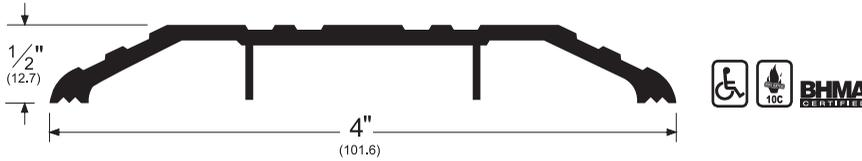

175_

AVAILABLE FINISHES: **10BE, A, B, BSP, D, WSP**
ANSI (aluminum): **J32300, J32330**
ANSI (brass): **J12300, J12330**

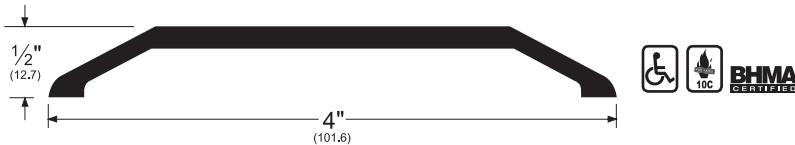

154_

AVAILABLE FINISHES: **10BE, A, BSP, D, WSP**
ANSI (aluminum): **J32300, J32330**

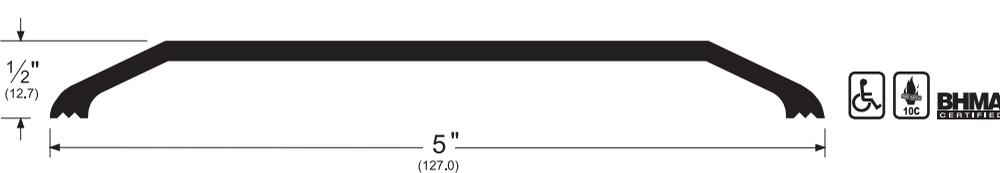

1547_

AVAILABLE FINISHES: **10BE, A, BSP, D, WSP**
ANSI (aluminum): **J32300, J32330**

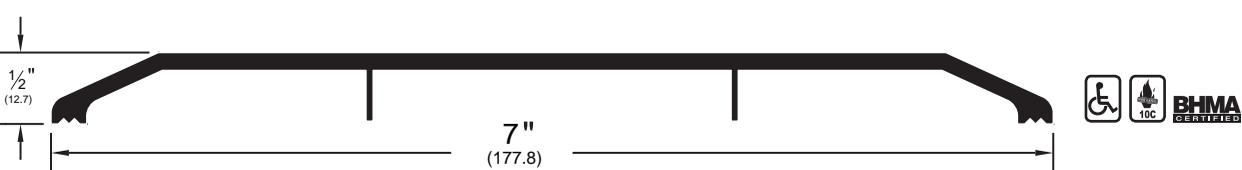

NOTE: Products shown in this section may not be drawn to scale.

AVAILABLE FINISHES FOR PRODUCTS SHOWN ON THIS PAGE

10BE (Satin Bronze Powder Coated Aluminum) **A** (Mill Finish Aluminum) **B** (Mill Finish Extruded Bronze [Brass])
BDG (Bright Dip Gold Anodized) **BSP** (Black Suede Powder Coated Aluminum) **D** (Dark Bronze Anodized)
WSP (White Suede Powder Coated Aluminum)

PEMKO
ASSA ABLOY

Experience a safer
and more open world

800-824-3018 | www.pemko.com
Check the web site for the up-to-date catalog

Copyright © 2015-2024, ASSA ABLOY Accessories and Door Controls Group, Inc., an ASSA ABLOY Group company. All rights reserved.
Reproduction in whole or in part without the express written permission of ASSA ABLOY Accessories and Door Controls Group, Inc. is prohibited.

SADDLE THRESHOLDS (Cont.)

1710_

AVAILABLE FINISH: **10BE, A, BSP, WSP**

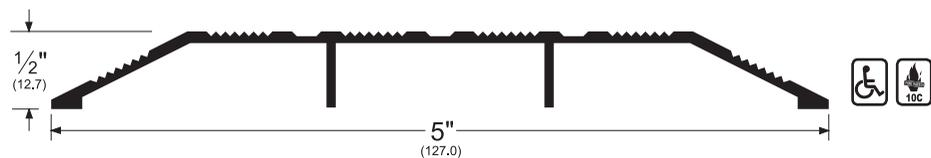

171_

AVAILABLE FINISHES: **10BE, A, B, BDG, BSP, D, G, WSP**

ANSI (aluminum): **J32100, J32130**

ANSI (brass): **J12100, J12130**

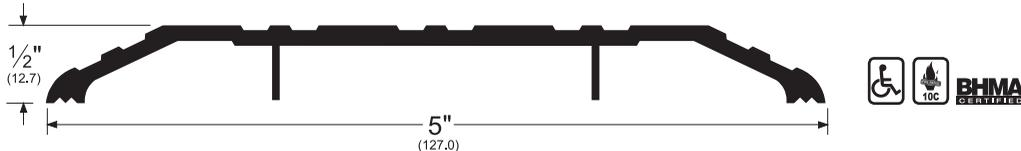

172_

AVAILABLE FINISHES: **10BE, A, B, BSP, D, WSP**

ANSI (aluminum): **J32100, J32130**

ANSI (brass): **J12100, J12130**



176_

AVAILABLE FINISHES: **10BE, A, B, BSP, D, WSP**

ANSI (aluminum): **J32100, J32130, J39100, J39130, J39135, J39150**

ANSI (brass): **J12100, J12130, J19100, J19130, J19135, J19150**

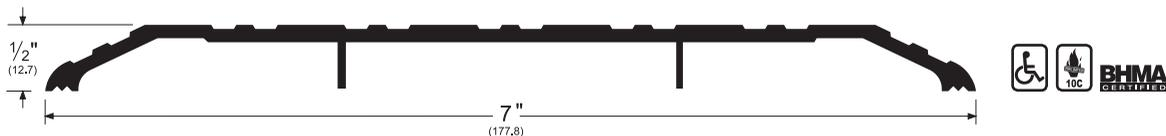

2548_

AVAILABLE FINISHES: **10BE, A, BSP, D, WSP**

ANSI (aluminum): **J32100, J32130, J39100, J39130, J39135, J39150**

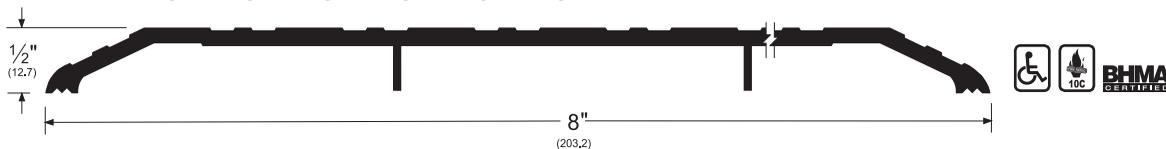

NOTE: Products shown in this section may not be drawn to scale.

AVAILABLE FINISHES FOR PRODUCTS SHOWN ON THIS PAGE

10BE (Satin Bronze Powder Coated Aluminum) **A** (Mill Finish Aluminum) **B** (Mill Finish Extruded Bronze [Brass])

BSP (Black Suede Powder Coated Aluminum) **D** (Dark Bronze Anodized) **G** (Gold Anodized)

WSP (White Suede Powder Coated Aluminum)

800-824-3018 | www.pemko.com

Check the web site for the up-to-date catalog

Copyright © 2015-2024, ASSA ABLOY Accessories and Door Controls Group, Inc., an ASSA ABLOY Group company. All rights reserved.

Reproduction in whole or in part without the express written permission of ASSA ABLOY Accessories and Door Controls Group, Inc. is prohibited.

PEMCO
ASSA ABLOY

Experience a safer
and more open world

SADDLE THRESHOLDS (Cont.)

254x4_

AVAILABLE FINISH: **B**

ANSI (brass): **J12100, J12130, J19100, J19130, J19135, J19150**

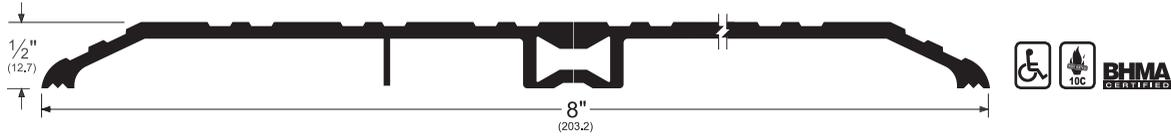

Welded on bottom. Includes two support legs (only one shown due to break in drawing)

2549_

AVAILABLE FINISHES: **10BE, A, BSP, D, WSP**

ANSI (aluminum): **J32100, J32130**

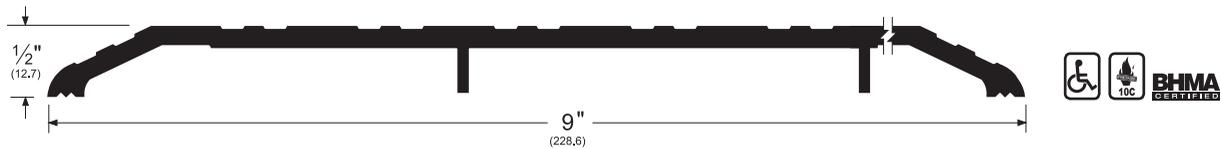

2550_

AVAILABLE FINISHES: **10BE, A, BSP, D, WSP**

ANSI (aluminum): **J32100, J32130**

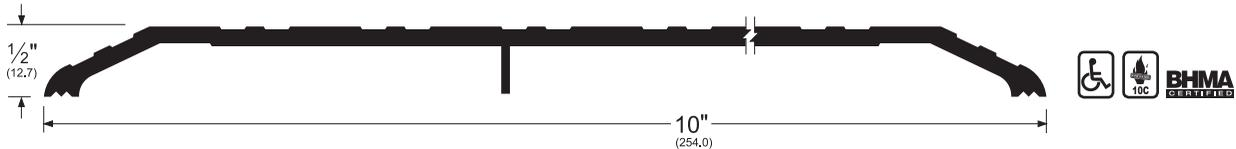

Includes two support legs (only one shown due to break in drawing)

255x5_

AVAILABLE FINISH: **B**

ANSI (brass): **J12100, J12130**



Welded on bottom. Includes two support legs (only one shown due to break in drawing)

256x6_

AVAILABLE FINISHES: **10BE, A, BSP, D, WSP**

ANSI (aluminum): **J32100, J32130**



Welded on bottom. Includes two support legs (only one shown due to break in drawing)

NOTE: Products shown in this section may not be drawn to scale.

AVAILABLE FINISHES FOR PRODUCTS SHOWN ON THIS PAGE

10BE (Satin Bronze Powder Coated Aluminum) **A** (Mill Finish Aluminum) **B** (Mill Finish Extruded Bronze [Brass])

BSP (Black Suede Powder Coated Aluminum) **D** (Dark Bronze Anodized)

WSP (White Suede Powder Coated Aluminum)

PEMKO
ASSA ABLOY

Experience a safer
and more open world

800-824-3018 | www.pemko.com
Check the web site for the up-to-date catalog

Copyright © 2015-2024, ASSA ABLOY Accessories and Door Controls Group, Inc., an ASSA ABLOY Group company. All rights reserved.
Reproduction in whole or in part without the express written permission of ASSA ABLOY Accessories and Door Controls Group, Inc. is prohibited.

HALF SADDLE THRESHOLDS

278_

AVAILABLE FINISHES: **10BE, A, BSP, D, WSP**
 ANSI (aluminum): **J33100, J33130, J33133**

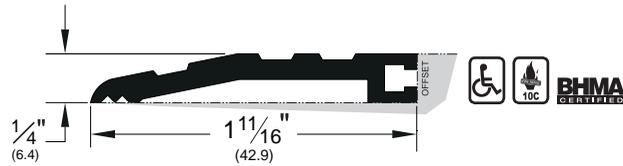

279_

AVAILABLE FINISHES: **10BE, A, BSP, D, WSP**
 ANSI (aluminum): **J33100, J33130, J33133**

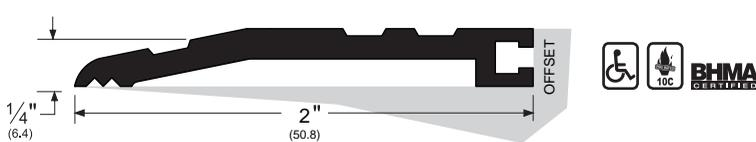

273_

AVAILABLE FINISHES: **10BE, A, B, BSP, D, WSP**
 ANSI (aluminum): **J33100, J33130, J33133**
 ANSI (brass): **J13100, J13130, J13133**

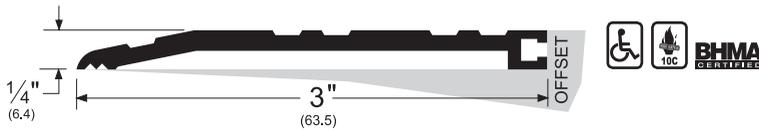

274_

AVAILABLE FINISHES: **10BE, A, B, BSP, D, WSP**
 ANSI (aluminum): **J33100, J33130, J33133**
 ANSI (brass): **J13100, J13130, J13133**

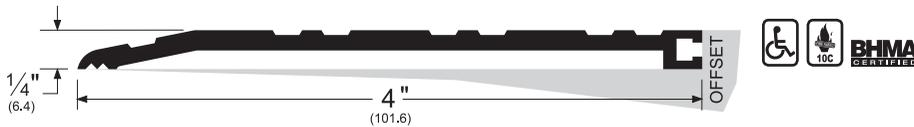

2746_

AVAILABLE FINISHES: **10BE, A, BSP, D, WSP**
 ANSI (aluminum): **J33100, J33130, J33133**

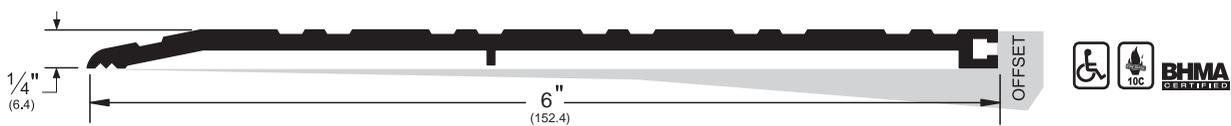

2755_

AVAILABLE FINISHES: **10BE, A, BSP, D, WSP**
 Ratings: **ADA, 10c, BHMA**

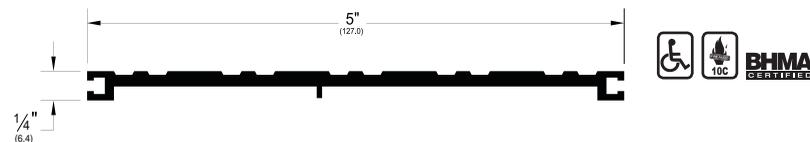

NOTE: Products shown in this section may not be drawn to scale.

AVAILABLE FINISHES FOR PRODUCTS SHOWN ON THIS PAGE

10BE (Satin Bronze Powder Coated Aluminum) **A** (Mill Finish Aluminum) **B** (Mill Finish Extruded Bronze [Brass])
BSP (Black Suede Powder Coated Aluminum) **D** (Dark Bronze Anodized) **WSP** (White Suede Powder Coated Aluminum)

800-824-3018 | www.pemko.com

Check the web site for the up-to-date catalog

Copyright © 2015-2024, ASSA ABLOY Accessories and Door Controls Group, Inc., an ASSA ABLOY Group company. All rights reserved.
 Reproduction in whole or in part without the express written permission of ASSA ABLOY Accessories and Door Controls Group, Inc. is prohibited.

PEMKO
ASSA ABLOY

Experience a safer
 and more open world

HALF SADDLE THRESHOLDS *(Cont.)*

252_

AVAILABLE FINISHES: **10BE, A, B, BSP, D, WSP**
 ANSI (aluminum): **J33100, J33130**
 ANSI (brass): **J13100, J13130**

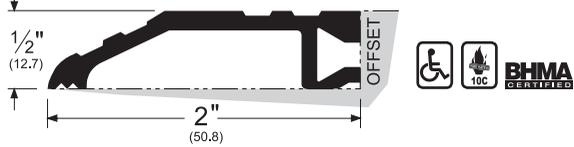

253_

AVAILABLE FINISHES: **10BE, A, B, BSP, D, WSP**
 ANSI (aluminum): **J33100, J33130**
 ANSI (brass): **J13100, J13130**

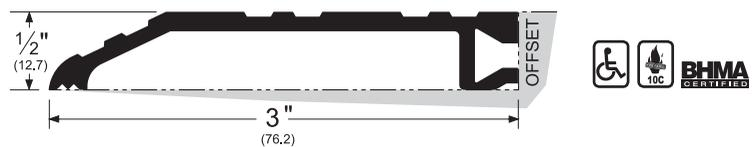

254_

AVAILABLE FINISHES: **10BE, A, B, BSP, D, G, WSP**
 ANSI (aluminum): **J33100, J33130**
 ANSI (brass): **J13100, J13130**

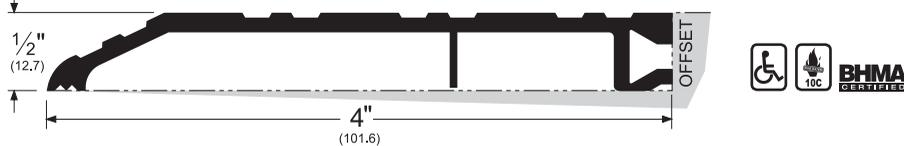

255_

AVAILABLE FINISHES: **10BE, A, B, BSP, D, G, WSP**
 ANSI (aluminum): **J33100, J33130**
 ANSI (brass): **J13100, J13130**

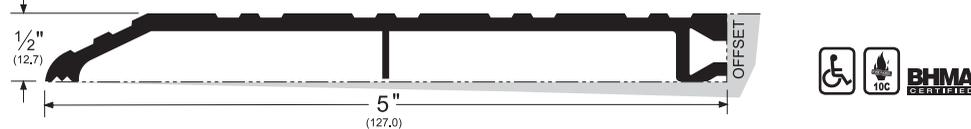

2555_

AVAILABLE FINISHES: **10BE, A, BSP, D, WSP**
 ANSI (aluminum): **J33100**



* 2555_ can be combined with other half saddles on one or both sides. If combined only on one side, the opposite side should be mounted flush with an existing offset. Either stated application is required for this to be ADA-compliant.

256_

AVAILABLE FINISHES: **10BE, A, BSP, D, WSP**
 ANSI (aluminum): **J33100, J33130**

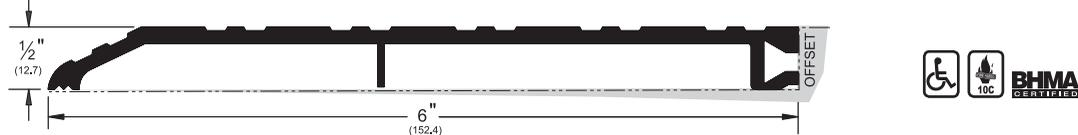

2565_

AVAILABLE FINISHES: **10BE, A, BSP, D, WSP**
 ANSI (aluminum): **J33100, J33130**

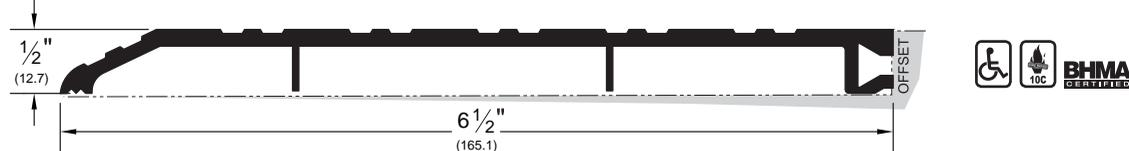

NOTE: Products shown in this section may not be drawn to scale.

AVAILABLE FINISHES FOR PRODUCTS SHOWN ON THIS PAGE

10BE (Satin Bronze Powder Coated Aluminum) **A** (Mill Finish Aluminum) **B** (Mill Finish Extruded Bronze [Brass])
BSP (Black Suede Powder Coated Aluminum) **D** (Dark Bronze Anodized) **G** (Gold Anodized)
WSP (White Suede Powder Coated Aluminum)

NOTE: **G** is available with limited inventory



Experience a safer and more open world

800-824-3018 | www.pemko.com
 Check the web site for the up-to-date catalog

Copyright © 2015-2024, ASSA ABLOY Accessories and Door Controls Group, Inc., an ASSA ABLOY Group company. All rights reserved. Reproduction in whole or in part without the express written permission of ASSA ABLOY Accessories and Door Controls Group, Inc. is prohibited.

OFFSET HALF SADDLES

566_

AVAILABLE FINISHES: **A, BSP, D, WSP, 10BE**

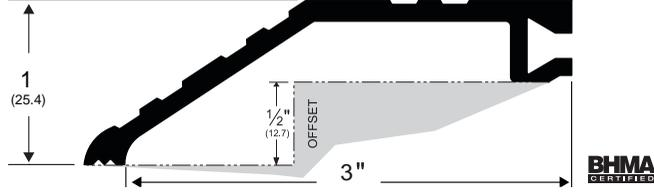

766_

AVAILABLE FINISHES: **A, BSP, D, WSP, 10BE**

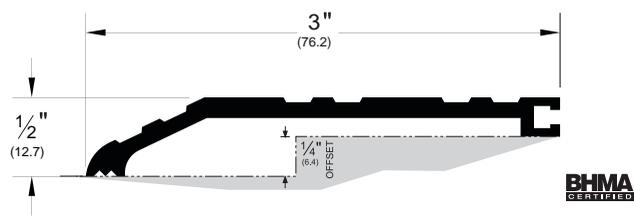

OFFSET SADDLES

158_

AVAILABLE FINISHES: **10BE, A, BSP, D, WSP**
ANSI (aluminum): **J32100, J32130, J32138, J32180**

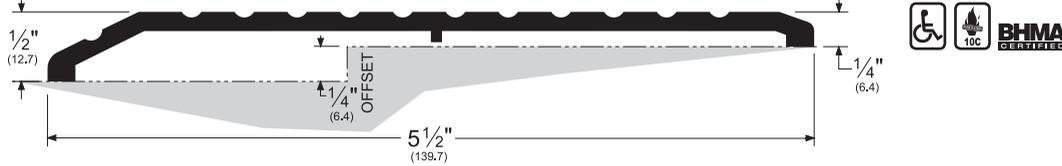

2727_

AVAILABLE FINISHES: **10BE, A, BSP, D, WSP**
ANSI (aluminum): **J32100, J32130, J32138, J32180**



157_

AVAILABLE FINISHES: **10BE, A, BSP, D, WSP**
ANSI (aluminum): **J32100, J32180, J33100**

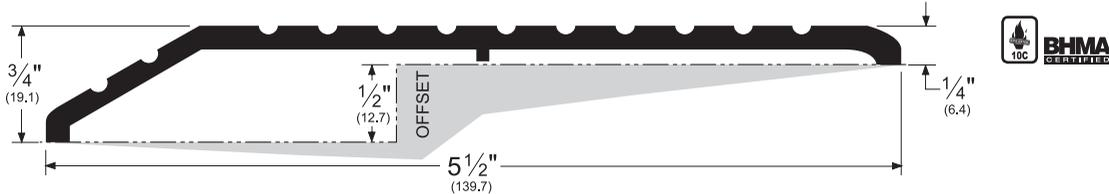

182_

AVAILABLE FINISHES: **10BE, A, BSP, D, WSP**
ANSI (aluminum): **J32100, J32180, J33100**

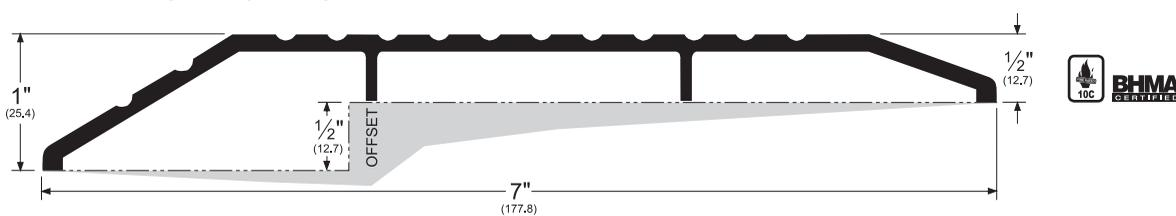

NOTE: Products shown in this section may not be drawn to scale.

AVAILABLE FINISHES FOR PRODUCTS SHOWN ON THIS PAGE

10BE (Satin Bronze Powder Coated Aluminum) **A** (Mill Finish Aluminum) **BSP** (Black Suede Powder Coated Aluminum)
D (Dark Bronze Anodized) **WSP** (White Suede Powder Coated Aluminum)

800-824-3018 | www.pemko.com

Check the web site for the up-to-date catalog

Copyright © 2015-2024, ASSA ABLOY Accessories and Door Controls Group, Inc., an ASSA ABLOY Group company. All rights reserved.
Reproduction in whole or in part without the express written permission of ASSA ABLOY Accessories and Door Controls Group, Inc. is prohibited.

PEMCO
ASSA ABLOY

Experience a safer
and more open world

STAINLESS STEEL SADDLES

154SS_

AVAILABLE FINISH: **SS (#4, Brushed Finish)**
ANSI: **J52300, J52330**

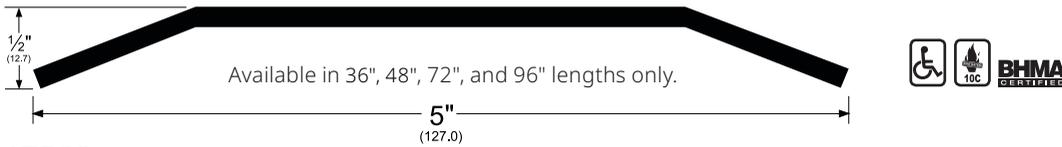

175SS_

AVAILABLE FINISH: **SS (#4, Brushed Finish)**
ANSI: **J52300, J52330**

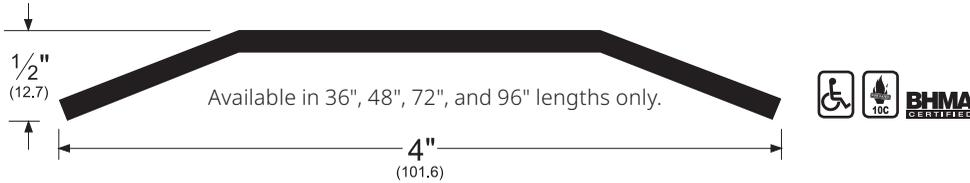

STAINLESS STEEL HALF SADDLES

- Available in 36", 48", 72", and 96" lengths only.

252SS_

AVAILABLE FINISH: **SS (#4, Brushed Finish)**
ANSI: **J52300, J52330**

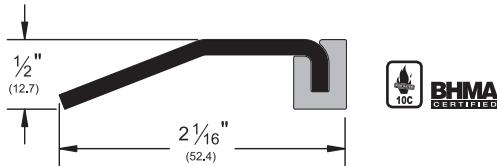

253SS_

AVAILABLE FINISH: **SS (#4, Brushed Finish)**
ANSI: **J52300, J52330**

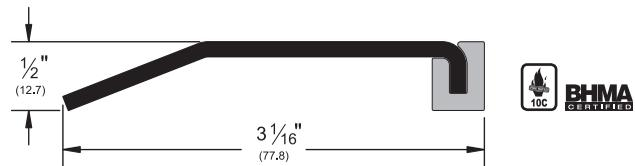

254SS_

AVAILABLE FINISH: **SS (#4, Brushed Finish)**
ANSI: **J52300, J52330**

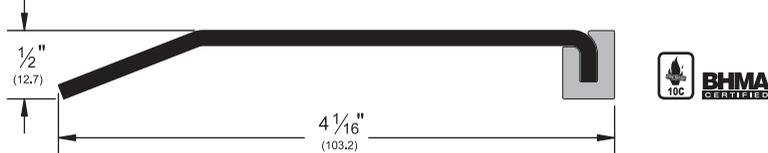

STAINLESS STEEL OFFSET SADDLES

- Available in 36", 48", 72", and 96" lengths only.

158SS_

AVAILABLE FINISH: **SS (#4, Brushed Finish)**
ANSI: **J52300, J52380, J52388**

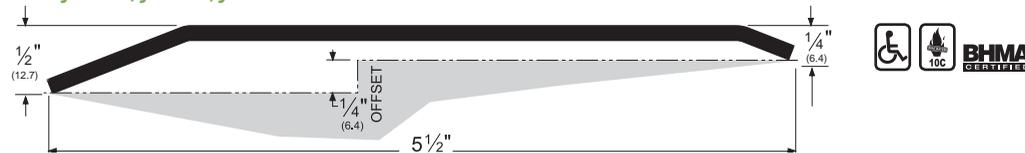

NOTE: Products shown in this section may not be drawn to scale.

AVAILABLE FINISHES FOR PRODUCTS SHOWN ON THIS PAGE
SS (See Individual Part)

PEMKO
ASSA ABLOY

Experience a safer
and more open world

800-824-3018 | www.pemko.com
Check the web site for the up-to-date catalog

Copyright © 2015-2024, ASSA ABLOY Accessories and Door Controls Group, Inc., an ASSA ABLOY Group company. All rights reserved.
Reproduction in whole or in part without the express written permission of ASSA ABLOY Accessories and Door Controls Group, Inc. is prohibited.

THERMAL BREAK SADDLES

- Black rigid polypropylene key between extrusions provides a thermal break (designated by "FG" Frost Guard following finish code)

273x3_FG

AVAILABLE FINISHES: **10BE, A, B, BSP, D, WSP**
 ANSI (aluminum): **J32139, J32190, J32193**
 ANSI (brass): **J12139, J12190, J12193**

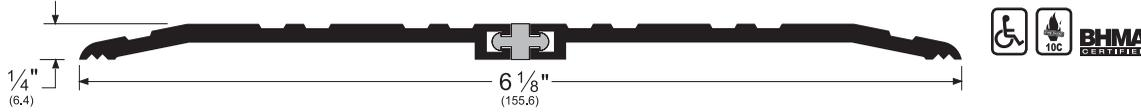

273x4_FG

AVAILABLE FINISHES: **10BE, A, B, BSP, D, WSP**
 ANSI (aluminum): **J32139, J32190, J32193**
 ANSI (brass): **J12139, J12190, J12193**

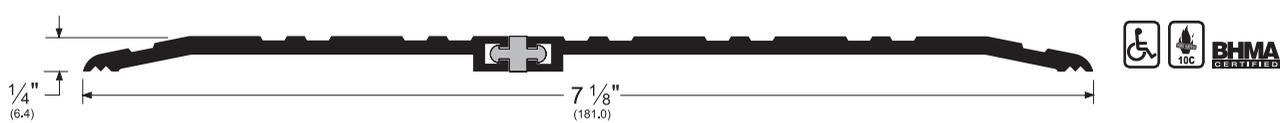

274x4_FG

AVAILABLE FINISHES: **10BE, A, B, BSP, D, WSP**
 ANSI (aluminum): **J32139, J32190, J32193**
 ANSI (brass): **J12139, J12190, J12193**

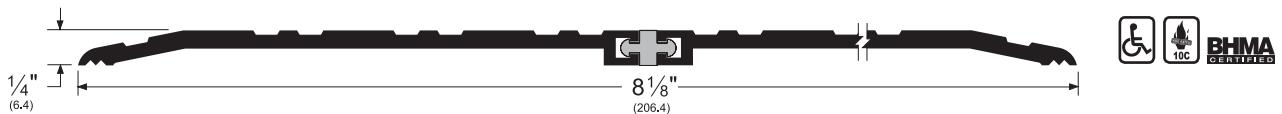

2746x6_FG

AVAILABLE FINISHES: **10BE, A, BSP, D, WSP**
 ANSI (aluminum): **J32139, J32190, J32193**

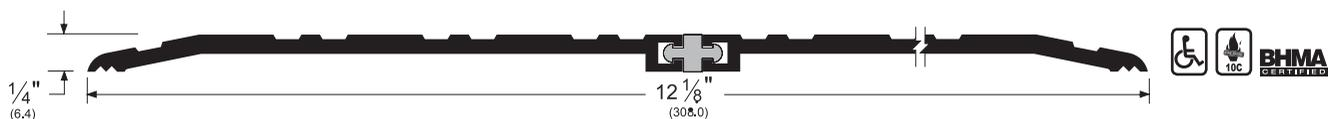

256x6_FG

AVAILABLE FINISHES: **10BE, A, BSP, D, WSP**
 ANSI (aluminum): **J32139, J32190, J32193**

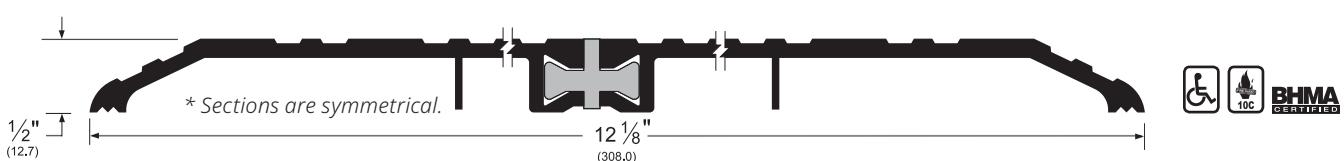

NOTE: Products shown in this section may not be drawn to scale.

AVAILABLE FINISHES FOR PRODUCTS SHOWN ON THIS PAGE

10BE (Satin Bronze Powder Coated Aluminum) **A** (Mill Finish Aluminum) **B** (Mill Finish Extruded Bronze [Brass])
BSP (Black Suede Powder Coated Aluminum) **D** (Dark Bronze Anodized) **WSP** (White Suede Powder Coated Aluminum)

800-824-3018 | www.pemko.com

Check the web site for the up-to-date catalog

Copyright © 2015-2024, ASSA ABLOY Accessories and Door Controls Group, Inc., an ASSA ABLOY Group company. All rights reserved.
 Reproduction in whole or in part without the express written permission of ASSA ABLOY Accessories and Door Controls Group, Inc. is prohibited.

PEMKO
ASSA ABLOY

Experience a safer
 and more open world

THERMAL BREAK SADDLES (Cont.)

255x5_FG

AVAILABLE FINISHES: **10BE, A, B, BSP, D, WSP**

ANSI (aluminum): **J32139, J32190, J32193**

ANSI (brass): **J12139, J12190, J12193**

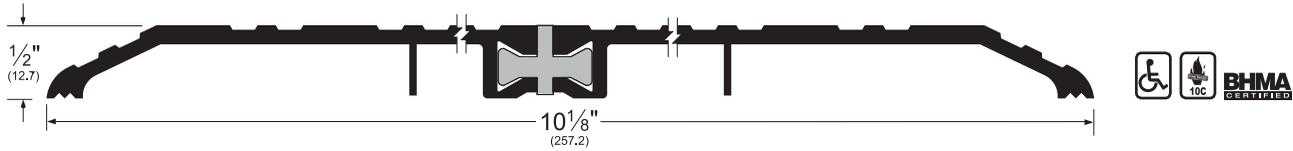

252x2_FG

AVAILABLE FINISHES: **10BE, A, B, BSP, D, WSP**

ANSI (aluminum): **J32139, J32190, J32193**

ANSI (brass): **J12139, J12190, J12193**

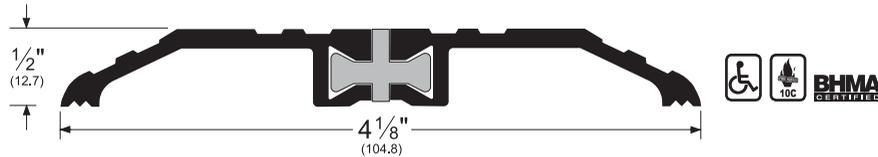

252x3_FG

AVAILABLE FINISHES: **10BE, A, B, BSP, D, WSP**

ANSI (aluminum): **J32139, J32190, J32193**

ANSI (brass): **J12139, J12190, J12193**

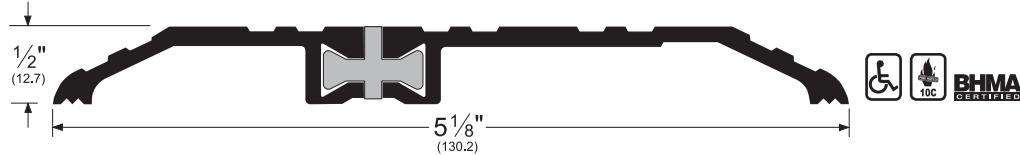

253x3_FG

AVAILABLE FINISHES: **10BE, A, B, BSP, D, WSP**

ANSI (aluminum): **J32139, J32190, J32193**

ANSI (brass): **J12139, J12190, J12193**

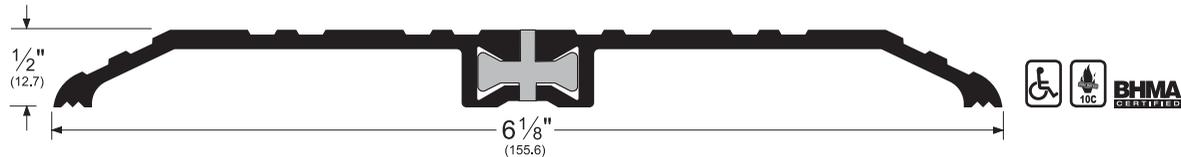

253x4_FG

AVAILABLE FINISHES: **10BE, A, B, BSP, D, WSP**

ANSI (aluminum): **J32139, J32190, J32193**

ANSI (brass): **J12139, J12190, J12193**

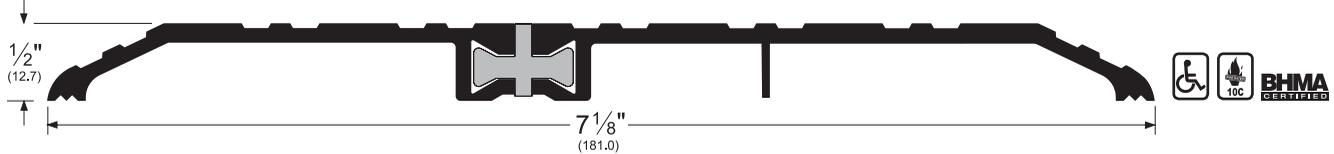

NOTE: Products shown in this section may not be drawn to scale.

AVAILABLE FINISHES FOR PRODUCTS SHOWN ON THIS PAGE

10BE (Satin Bronze Powder Coated Aluminum) **A** (Mill Finish Aluminum) **B** (Mill Finish Extruded Bronze [Brass])

BSP (Black Suede Powder Coated Aluminum) **D** (Dark Bronze Anodized) **WSP** (White Suede Powder Coated Aluminum)



Experience a safer
and more open world

800-824-3018 | www.pemko.com
Check the web site for the up-to-date catalog

Copyright © 2015-2024, ASSA ABLOY Accessories and Door Controls Group, Inc., an ASSA ABLOY Group company. All rights reserved.
Reproduction in whole or in part without the express written permission of ASSA ABLOY Accessories and Door Controls Group, Inc. is prohibited.

THERMAL BREAK SADDLES (Cont.)

253x6_FG

AVAILABLE FINISHES: **10BE, A, BSP, D, WSP**
 ANSI (aluminum): **J32139, J32190, J32193**

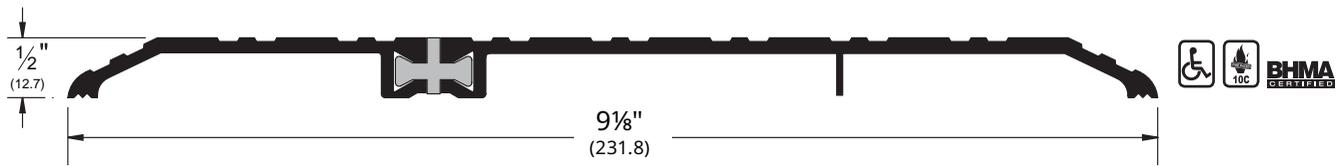

254x4_FG

AVAILABLE FINISHES: **10BE, A, B, BSP, D, WSP**
 ANSI (aluminum): **J32139, J32190, J32193**
 ANSI (brass): **J12139, J12190, J12193**

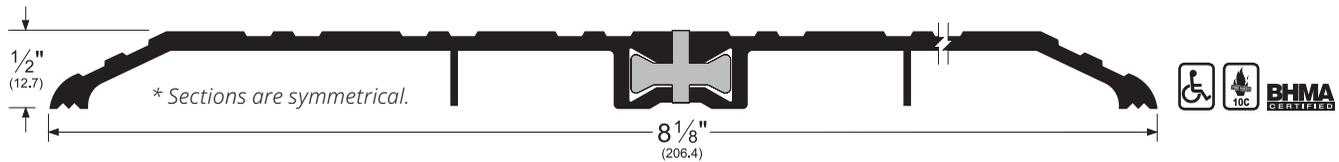

254x5_FG

AVAILABLE FINISHES: **10BE, A, B, BSP, D, WSP**
 ANSI (aluminum): **J32139, J32190, J32193**
 ANSI (brass): **J12139, J12190, J12193**

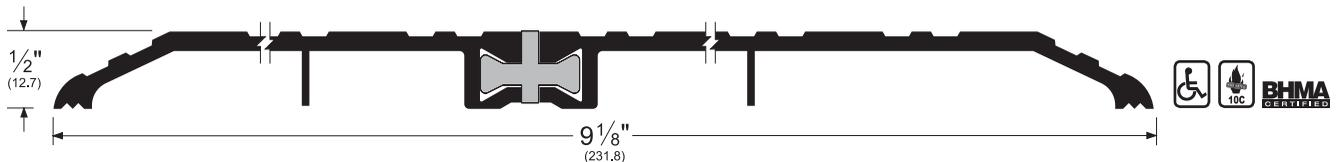

* Sections are symmetrical.

766x5_FG

AVAILABLE FINISHES: **10BE, A, BSP, D, WSP**
 ANSI (aluminum): **J32139, J32190, J32193, J32189, J32180**
 ANSI (brass): **J12139, J12190, J12193, J12189, J12180**

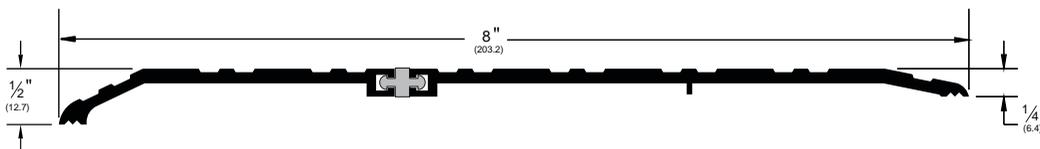

566x3_FG

AVAILABLE FINISHES: **10BE, A, BSP, D, WSP**
 ANSI (aluminum): **J32189, J32190, J32180**

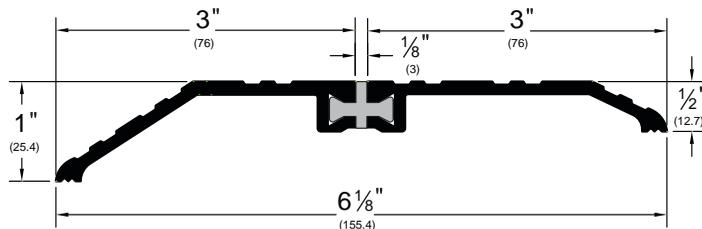

NOTE: Products shown in this section may not be drawn to scale.

AVAILABLE FINISHES FOR PRODUCTS SHOWN ON THIS PAGE

10BE (Satin Bronze Powder Coated Aluminum) **A** (Mill Finish Aluminum) **B** (Mill Finish Extruded Bronze [Brass])
BSP (Black Suede Powder Coated Aluminum) **D** (Dark Bronze Anodized) **WSP** (White Suede Powder Coated Aluminum)

800-824-3018 | www.pemko.com

Check the web site for the up-to-date catalog

Copyright © 2015-2024, ASSA ABLOY Accessories and Door Controls Group, Inc., an ASSA ABLOY Group company. All rights reserved.
 Reproduction in whole or in part without the express written permission of ASSA ABLOY Accessories and Door Controls Group, Inc. is prohibited.

PEMKO
ASSA ABLOY

Experience a safer
 and more open world

STAINLESS STEEL THERMAL BREAK THRESHOLD

- Black rigid polypropylene key between extrusions provides a thermal barrier (designated by "FG" Frost Guard following finish code)
- Available in 36", 48", 72", and 96" lengths only

252x2SSFG

AVAILABLE FINISH: **SS (#4, Brushed Finish)**

ANSI: **J52330, J52339, J52390, J52393**

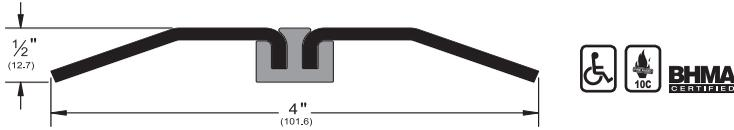

252x3SSFG

AVAILABLE FINISH: **SS (#4, Brushed Finish)**

ANSI: **J52330, J52339, J52390, J52393**

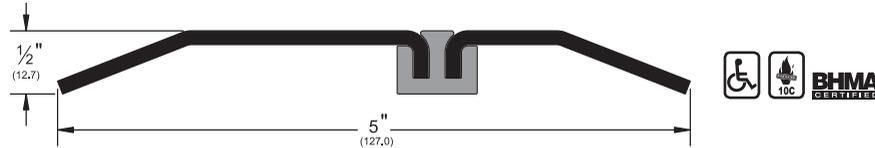

252x4SSFG

AVAILABLE FINISH: **SS (#4, Brushed Finish)**

ANSI: **J52330, J52339, J52390, J52393**

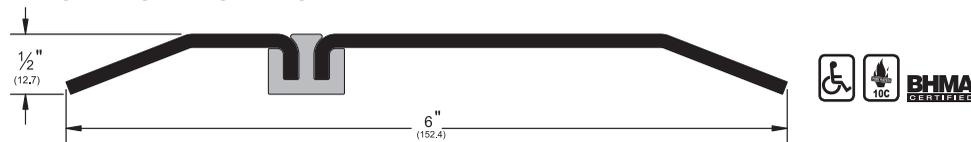

253x3SSFG

AVAILABLE FINISH: **SS (#4, Brushed Finish)**

ANSI: **J52330, J52339, J52390, J52393**

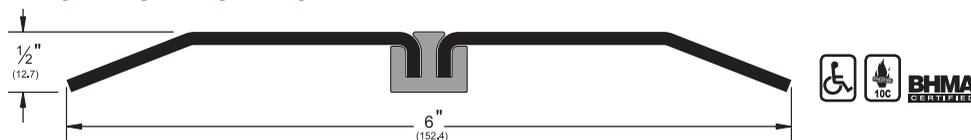

253x4SSFG

AVAILABLE FINISH: **SS (#4, Brushed Finish)**

ANSI: **J52330, J52339, J52390, J52393**



254x4SSFG

AVAILABLE FINISH: **SS (#4, Brushed Finish)**

ANSI: **J52330, J52339, J52390, J52393**

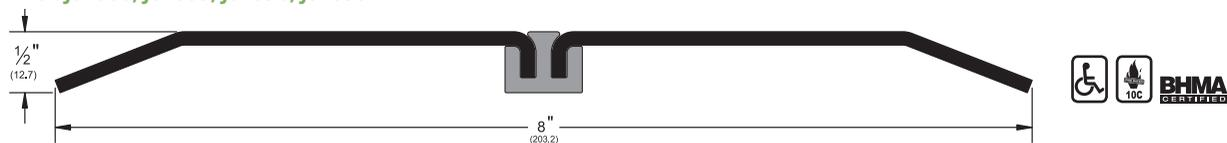

NOTE: Products shown in this section may not be drawn to scale.

AVAILABLE FINISHES FOR PRODUCTS SHOWN ON THIS PAGE
SS (See Individual Part)



Experience a safer
and more open world

800-824-3018 | www.pemko.com
 Check the web site for the up-to-date catalog

Copyright © 2015-2024, ASSA ABLOY Accessories and Door Controls Group, Inc., an ASSA ABLOY Group company. All rights reserved.
 Reproduction in whole or in part without the express written permission of ASSA ABLOY Accessories and Door Controls Group, Inc. is prohibited.

LATCHING PANIC EXIT SADDLES

- Used in conjunction with surface applied vertical rod exit device, or as a stop and a seal at the bottom of door
- For offset applications, use an elevator (see page 131)
- **2006_T** is only ADA compliant when installed butted to 1/4" tile or other floor material

2001_T

AVAILABLE FINISHES: **10BE, A, BSP, D, WSP**
 REPLACEMENT INSERT: **T5 (BL)**

- Allow 1/4" door clearance
- Special purpose bumper threshold designed for use with a low 1/4" to 3/8" undercut door.

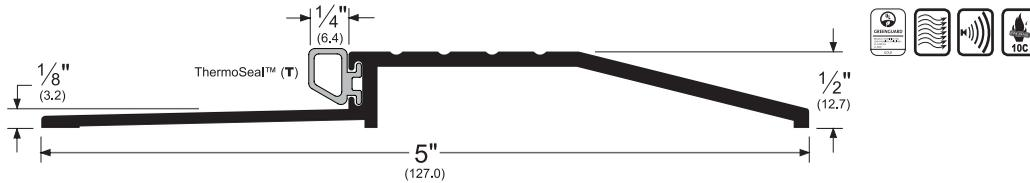

2005_T

AVAILABLE FINISH: **10BE, A, B, BSP, D, WSP**
 REPLACEMENT INSERT: **T5 (BL)**
 ANSI (aluminum): **J35100, J35130, J36100, J36130**
 ANSI (brass): **J15100, J15130, J16100, J16130**
 Allow 3/8" door clearance

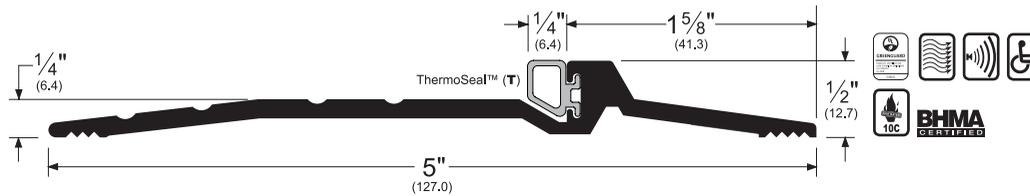

2006_T

AVAILABLE FINISH: **10BE, A, BSP, D, WSP**
 REPLACEMENT INSERT: **T5 (BL)**
 ANSI (aluminum): **J35100, J35130, J36100, J36130**
 Allow 3/8" door clearance

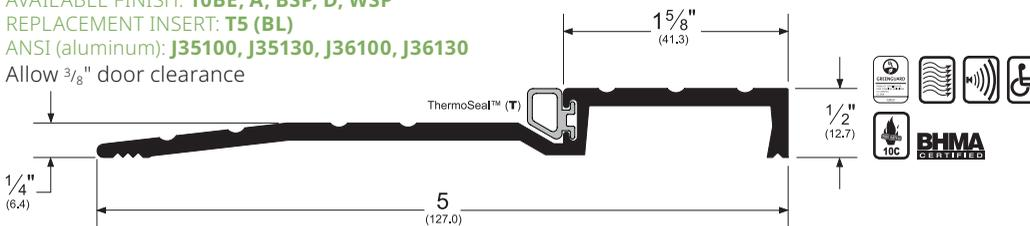

Alternate Inserts



pile (P)

2001_P  

2005_P  

2006_P  

REPLACEMENT INSERT:
P2 (BL, W)



Eco-V™ (V)

2001_V  

2005_V  

2006_V  

REPLACEMENT INSERT:
EV41 (BL, GR, W)

NOTE: Products shown in this section may not be drawn to scale.

AVAILABLE FINISHES FOR PRODUCTS SHOWN ON THIS PAGE

10BE (Satin Bronze Powder Coated Aluminum) **A** (Mill Finish Aluminum) **B** (Mill Finish Extruded Bronze [Brass])
BSP (Black Suede Powder Coated Aluminum) **D** (Dark Bronze Anodized)
WSP (White Suede Powder Coated Aluminum)

800-824-3018 | www.pemko.com

Check the web site for the up-to-date catalog

Copyright © 2015-2024, ASSA ABLOY Accessories and Door Controls Group, Inc., an ASSA ABLOY Group company. All rights reserved.
 Reproduction in whole or in part without the express written permission of ASSA ABLOY Accessories and Door Controls Group, Inc. is prohibited.

PEMCO
ASSA ABLOY

Experience a safer
 and more open world

LATCHING PANIC EXIT SADDLES (Cont.)

2009_PK

AVAILABLE FINISHES: **10BE, A, BSP, D, WSP**
 REPLACEMENT INSERT: **PK20 (BL)**
 ANSI: **J36100, J36130**

Allow $\frac{3}{8}$ " door clearance

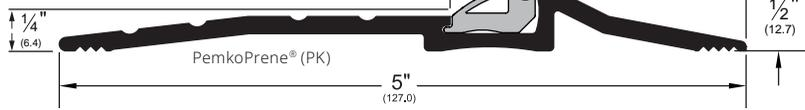

U.S. Patent No. 9,920,567

2010_PK

AVAILABLE FINISHES: **10BE, A, BSP, D, WSP**
 REPLACEMENT INSERT: **PK20 (BL)**
 ANSI: **J36100, J36130**

Allow $\frac{3}{8}$ " door clearance

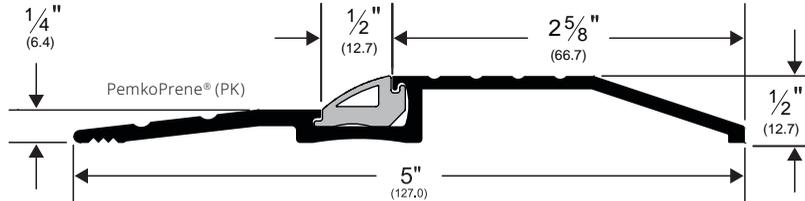

Alternate Inserts



pile (P)

179_P

REPLACEMENT INSERT:
P2 (BL, W)

179_T

AVAILABLE FINISHES: **10BE, A, BSP, D, WSP**
 REPLACEMENT INSERT: **T5 (BL)**
 ANSI (aluminum): **J35100, J36100**

Allow $\frac{1}{2}$ " door clearance

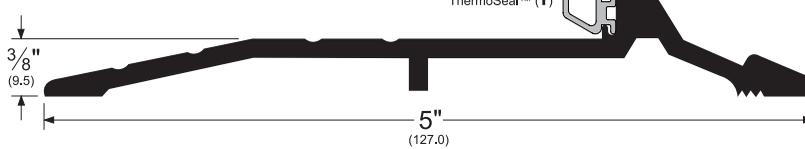

Eco-V™ (V)

179_V

REPLACEMENT INSERT:
EV41 (BL, GR, W)

277_S

AVAILABLE FINISHES: **10BE, A, BSP, D, WSP**
 REPLACEMENT INSERT: **SR6 (BL)**
 ANSI (aluminum): **J35100, J36100**

Allow $\frac{5}{8}$ " door clearance

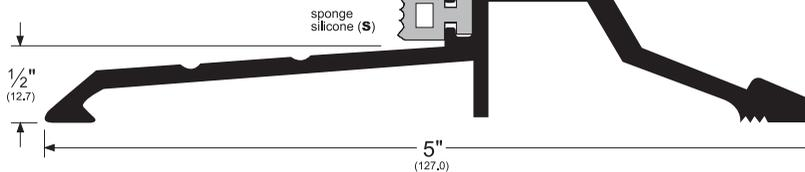

Alternate Inserts



sponge
 EPDM (R)

277_R

REPLACEMENT INSERT:
E7 (BL)
 ANSI (aluminum):
J36100

NOTE: Products shown in this section may not be drawn to scale.

AVAILABLE FINISHES FOR PRODUCTS SHOWN ON THIS PAGE

10BE (Satin Bronze Powder Coated Aluminum) **A** (Mill Finish Aluminum) **BSP** (Black Suede Powder Coated Aluminum) **D** (Dark Bronze Anodized) **WSP** (White Suede Powder Coated Aluminum)



Experience a safer
 and more open world

800-824-3018 | www.pemko.com
 Check the web site for the up-to-date catalog

Copyright © 2015-2024, ASSA ABLOY Accessories and Door Controls Group, Inc., an ASSA ABLOY Group company. All rights reserved. Reproduction in whole or in part without the express written permission of ASSA ABLOY Accessories and Door Controls Group, Inc. is prohibited.

LATCHING PANIC EXIT SADDLES (Cont.)

159_T

AVAILABLE FINISHES: **10BE, A, B, BSP, D, WSP**
 REPLACEMENT INSERT: **T5 (BL)**
 ANSI (aluminum): **J35300, J36300**
 ANSI (brass): **J15300, J16300**

- Allow $\frac{9}{16}$ " door clearance
- Provided with "J" hook.
- Can also be used as an interlock threshold (see Residential Thresholds section)

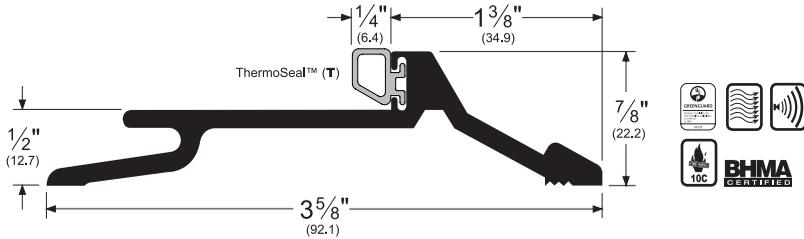

177_T

AVAILABLE FINISHES: **10BE, A, B, BSP, D, WSP**
 REPLACEMENT INSERT: **T5 (BL)**
 ANSI (aluminum): **J35100, J36100**
 ANSI (brass): **J15100, J16100**

Allow $\frac{5}{8}$ " door clearance

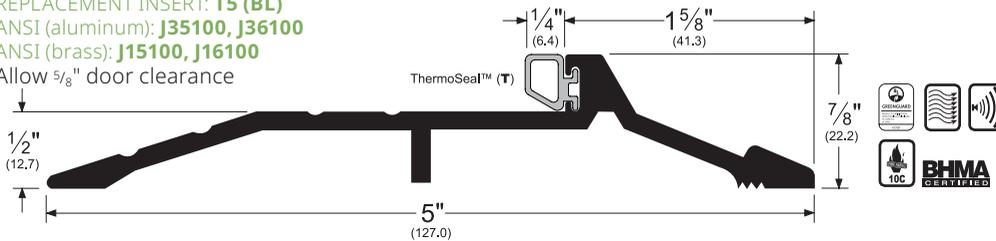

1855_T

AVAILABLE FINISHES: **10BE, A, BSP, WSP**
 REPLACEMENT INSERT: **T5 (BL)**
 ANSI (aluminum): **J35100, J36100**

Allow $\frac{5}{8}$ " door clearance

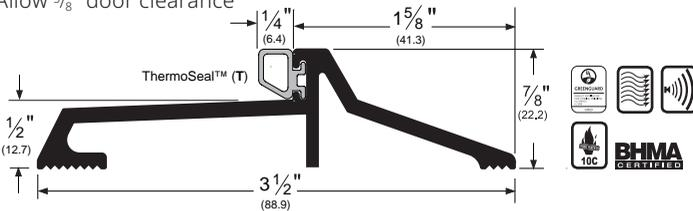

181_T

AVAILABLE FINISHES: **10BE, A, B, BSP, D, WSP**
 REPLACEMENT INSERT: **T5 (BL)**
 ANSI (aluminum): **J35100, J36100**
 ANSI (brass): **J15100, J16100**

Allow $\frac{3}{4}$ " door clearance

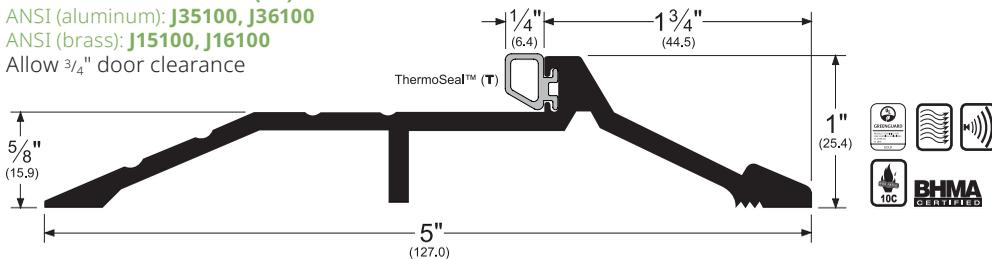

NOTE: Products shown in this section may not be drawn to scale.

AVAILABLE FINISHES FOR PRODUCTS SHOWN ON THIS PAGE

10BE (Satin Bronze Powder Coated Aluminum) **A** (Mill Finish Aluminum) **B** (Mill Finish Extruded Bronze [Brass])
BSP (Black Suede Powder Coated Aluminum) **D** (Dark Bronze Anodized) **WSP** (White Suede Powder Coated Aluminum)

800-824-3018 | www.pemko.com

Check the web site for the up-to-date catalog

Copyright © 2015-2024, ASSA ABLOY Accessories and Door Controls Group, Inc., an ASSA ABLOY Group company. All rights reserved.
 Reproduction in whole or in part without the express written permission of ASSA ABLOY Accessories and Door Controls Group, Inc. is prohibited.

Alternate Inserts



pile (P)

- 159_P
- 177_P
- 1855_P
- 181_P

REPLACEMENT INSERT:
P2 (BL, W)



Eco-V™ (V)

- 159_V
- 177_V
- 1855_V
- 181_V

REPLACEMENT INSERT:
EV41 (BL, GR, W)

PEMCO
ASSA ABLOY

Experience a safer
 and more open world

LATCHING PANIC EXIT SADDLES (Cont.)

185_T

AVAILABLE FINISHES: **10BE, A, BSP, WSP**
 REPLACEMENT INSERT: **T5 (BL)**
 ANSI (aluminum): **J35300, J36300**
 Allow 3/4" door clearance

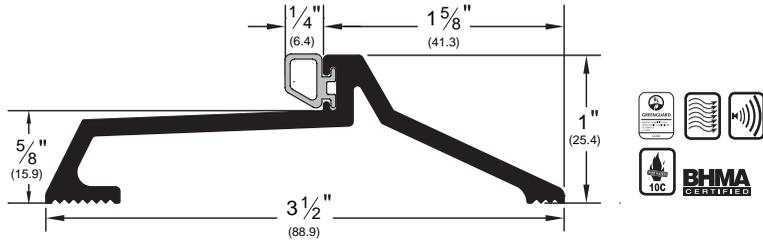

252x226_T

AVAILABLE FINISHES: **10BE, A, B, BSP, D, WSP**
 REPLACEMENT INSERT: **T5 (BL)**
 ANSI (aluminum): **J35100, J36100**
 ANSI (brass): **J15100, J16100**
 Allow 5/8" door clearance

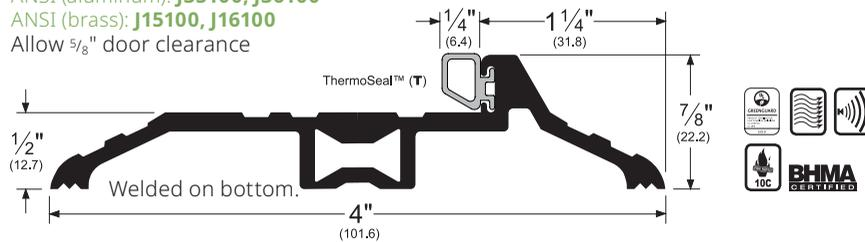

254x226_T

AVAILABLE FINISHES: **10BE, A, B, BSP, D, WSP**
 REPLACEMENT INSERT: **T5 (BL)**
 ANSI (aluminum): **J35100, J36100**
 ANSI (brass): **J15100, J16100**
 Allow 5/8" door clearance

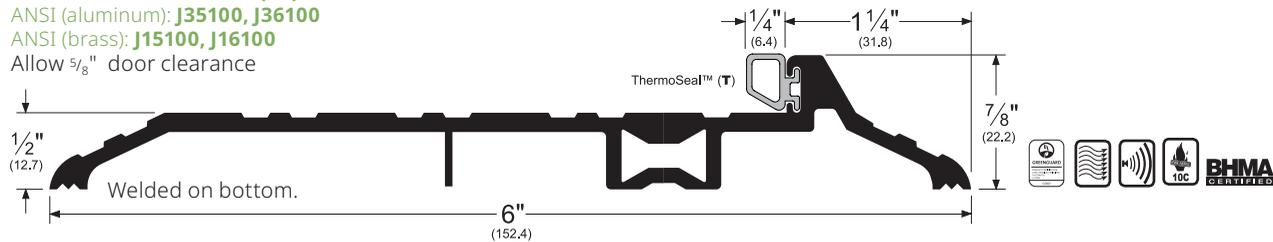

255x226_T

AVAILABLE FINISHES: **10BE, A, B, BSP, D, WSP**
 REPLACEMENT INSERT: **T5 (BL)**
 ANSI (aluminum): **J35100, J36100**
 ANSI (brass): **J15100, J16100**
 Allow 5/8" door clearance

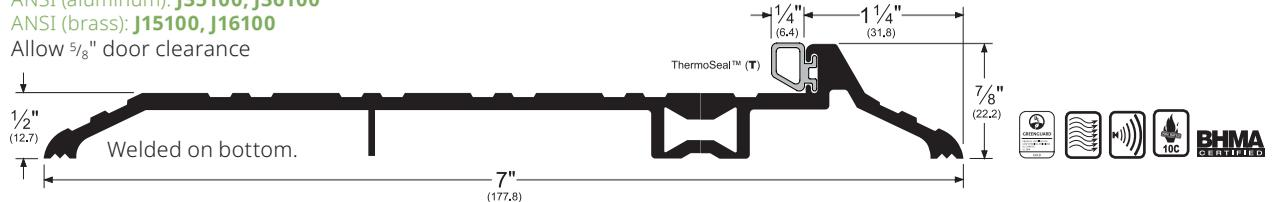

Alternate Inserts



- 185_P
- 252x226_P
- 254x226_P
- 255x226_P

REPLACEMENT INSERT:
P2 (BL, W)



- 185_V
- 252x226_V
- 254x226_V
- 255x226_V

REPLACEMENT INSERT:
EV41 (BL, GR, W)

NOTE: Products shown in this section may not be drawn to scale.

AVAILABLE FINISHES FOR PRODUCTS SHOWN ON THIS PAGE

10BE (Satin Bronze Powder Coated Aluminum) **A** (Mill Finish Aluminum) **B** (Mill Finish Extruded Bronze [Brass])
BSP (Black Suede Powder Coated Aluminum) **D** (Dark Bronze Anodized) **WSP** (White Suede Powder Coated Aluminum)



Experience a safer
 and more open world

800-824-3018 | www.pemko.com
 Check the web site for the up-to-date catalog

Copyright © 2015-2024, ASSA ABLOY Accessories and Door Controls Group, Inc., an ASSA ABLOY Group company. All rights reserved.
 Reproduction in whole or in part without the express written permission of ASSA ABLOY Accessories and Door Controls Group, Inc. is prohibited.

LATCHING PANIC EXIT SADDLES - THERMAL BREAK

- Black rigid polypropylene key between extrusions provides thermal break (designated by "FG" Frost Guard following finish code)
- Used in conjunction with surface applied vertical rod exit device, or as a stop and a seal at the bottom of door
- These units are not welded

252x226_FGT

AVAILABLE FINISHES: **10BE, A, B, BSP, D, WSP**

REPLACEMENT INSERT: **T5 (BL)**

ANSI (aluminum): **J35190, J36190**

ANSI (brass): **J15190, J16190**

Allow 5/8" door clearance

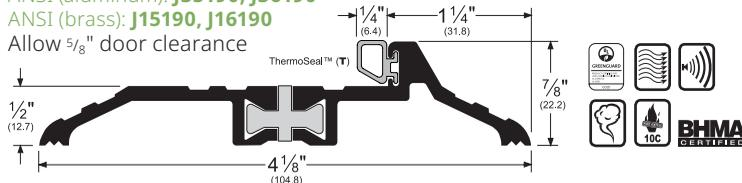

253x226_FGT

AVAILABLE FINISHES: **10BE, A, B, BSP, D, WSP**

REPLACEMENT INSERT: **T5 (BL)**

ANSI (aluminum): **J35190, J36190**

ANSI (brass): **J15190, J16190**

Allow 5/8" door clearance

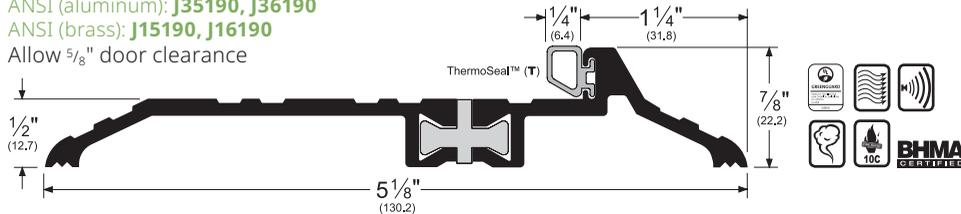

254x226_FGT

AVAILABLE FINISHES: **10BE, A, B, BSP, D, WSP**

REPLACEMENT INSERT: **T5 (BL)**

ANSI (aluminum): **J35190, J36190**

ANSI (brass): **J15190, J16190**

Allow 5/8" door clearance

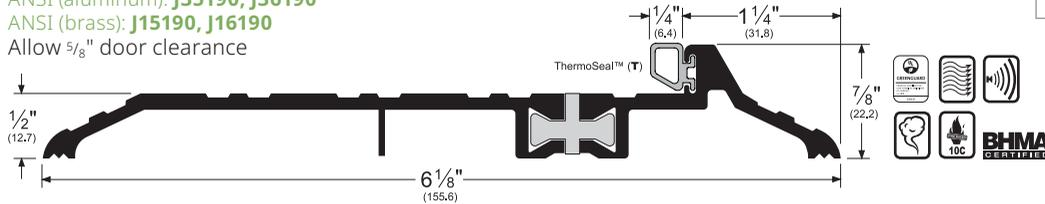

255x226_FGT

AVAILABLE FINISHES: **10BE, A, B, BSP, D, WSP**

REPLACEMENT INSERT: **T5 (BL)**

ANSI (aluminum): **J35190, J36190**

ANSI (brass): **J15190, J16190**

Allow 5/8" door clearance

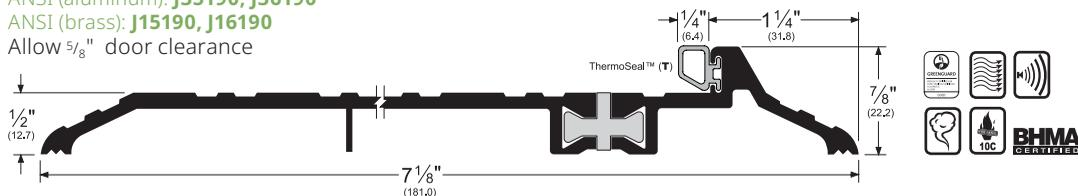

NOTE: Products shown in this section may not be drawn to scale.

AVAILABLE FINISHES FOR PRODUCTS SHOWN ON THIS PAGE

10BE (Satin Bronze Powder Coated Aluminum) **A** (Mill Finish Aluminum) **B** (Mill Finish Extruded Bronze [Brass])

BSP (Black Suede Powder Coated Aluminum) **D** (Dark Bronze Anodized) **WSP** (White Suede Powder Coated Aluminum)

Alternate Inserts



pile (P)

252x226_FGP 

253x226_FGP 

254x226_FGP 

255x226_FGP 

273x224_FGP 

REPLACEMENT INSERT: **P2 (BL, W)**



Eco-V™ (V)

252x226_FGV 

253x226_FGV 

254x226_FGV 

255x226_FGV 

273x224_FGV 

REPLACEMENT INSERT: **EV41 (BL, GR, W)**

800-824-3018 | www.pemko.com

Check the web site for the up-to-date catalog

Copyright © 2015-2024, ASSA ABLOY Accessories and Door Controls Group, Inc., an ASSA ABLOY Group company. All rights reserved. Reproduction in whole or in part without the express written permission of ASSA ABLOY Accessories and Door Controls Group, Inc. is prohibited.

PEMCO
ASSA ABLOY

Experience a safer
and more open world

LATCHING PANIC EXIT SADDLES - THERMAL BREAK (Cont.)

- Allow 3/8" door clearance

273x224_FGT

AVAILABLE FINISHES: **10BE, A, BSP, D, WSP**
 REPLACEMENT INSERT: **T5 (BL)**
 ANSI (aluminum): **J36130, J36139, J36190, J36193**

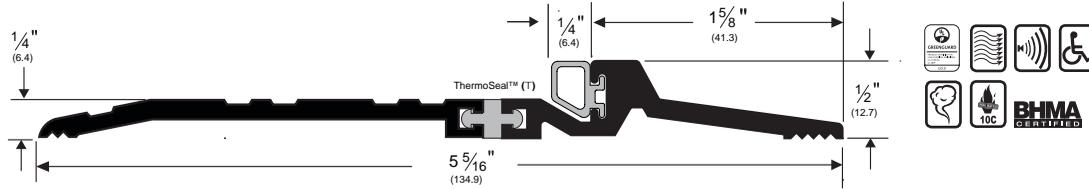

278x224_FGT

AVAILABLE FINISHES: **10BE, A, BSP, D, WSP**
 REPLACEMENT INSERT: **T5 (BL)**
 ANSI (aluminum): **J36130, J36139, J36190, J36193**

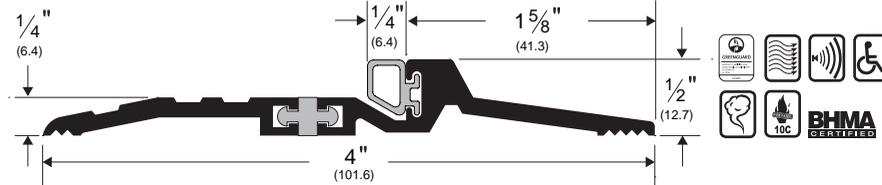

279x224_FGT

AVAILABLE FINISHES: **10BE, A, BSP, D, WSP**
 REPLACEMENT INSERT: **T5 (BL)**
 ANSI (aluminum): **J36130, J36139, J36190, J36193**

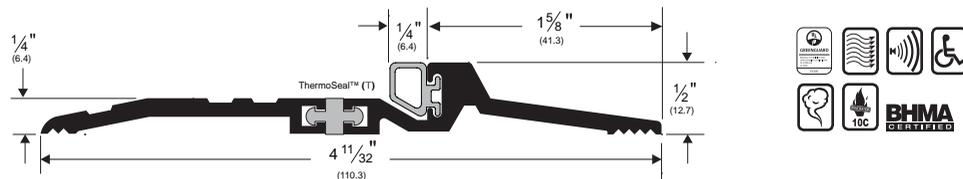

274x224_FGT

AVAILABLE FINISHES: **10BE, A, BSP, D, WSP**
 REPLACEMENT INSERT: **T5 (BL)**
 ANSI (aluminum): **J36130, J36139, J36190, J36193**

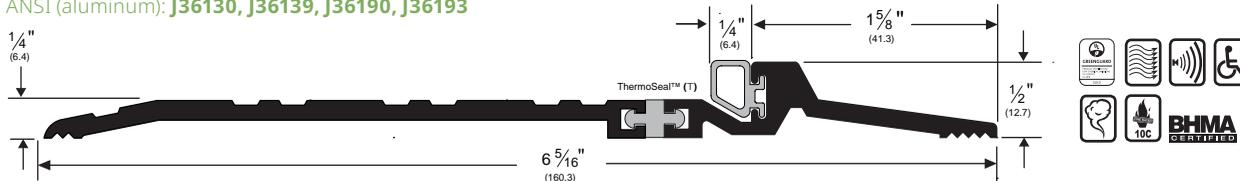

Alternate Inserts



pile (P)

- 273x224_FGP
- 274x224_FGP
- 278x224_FGP
- 279x224_FGP

REPLACEMENT INSERT: **P2 (BL, W)**



Eco-V™ (V)

- 273x224_FGV
- 274x224_FGV
- 278x224_FGV
- 279x224_FGV

REPLACEMENT INSERT: **EV41 (BL, GR, W)**

NOTE: Products shown in this section may not be drawn to scale.

AVAILABLE FINISHES FOR PRODUCTS SHOWN ON THIS PAGE

10BE (Satin Bronze Powder Coated Aluminum) **A** (Mill Finish Aluminum) **BSP** (Black Suede Powder Coated Aluminum) **D** (Dark Bronze Anodized) **WSP** (White Suede Powder Coated Aluminum)



Experience a safer and more open world

800-824-3018 | www.pemko.com
 Check the web site for the up-to-date catalog

Copyright © 2015-2024, ASSA ABLOY Accessories and Door Controls Group, Inc., an ASSA ABLOY Group company. All rights reserved. Reproduction in whole or in part without the express written permission of ASSA ABLOY Accessories and Door Controls Group, Inc. is prohibited.

LATCHING PANIC EXIT SADDLES - THERMAL BREAK (Cont.)

- Allow 3/8" door clearance

278x292_FGPK

AVAILABLE FINISHES: **10BE, A, BSP, D, WSP**
 REPLACEMENT INSERT: **PK20 (BL)**
 ANSI (aluminum): **J35190, J35193, J36190, J36193**

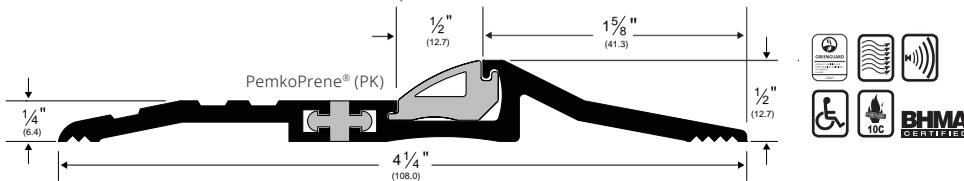

279x292_FGPK

AVAILABLE FINISHES: **10BE, A, BSP, D, WSP**
 REPLACEMENT INSERT: **PK20 (BL)**
 ANSI (aluminum): **J35190, J35193, J36190, J36193**

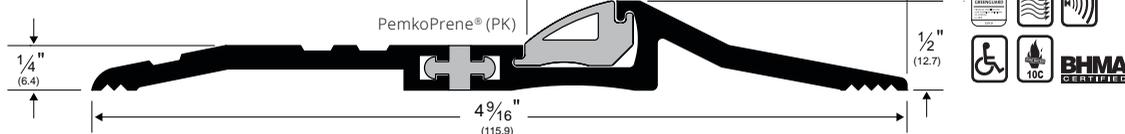

273x292_FGPK

AVAILABLE FINISHES: **10BE, A, BSP, D, WSP**
 REPLACEMENT INSERT: **PK20 (BL)**
 ANSI (aluminum): **J35190, J35193, J36190, J36193**

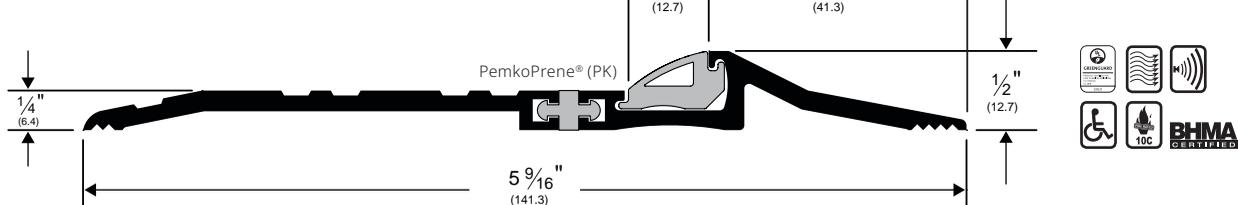

274x292_FGPK

AVAILABLE FINISHES: **10BE, A, BSP, D, WSP**
 REPLACEMENT INSERT: **PK20 (BL)**
 ANSI (aluminum): **J35190, J35193, J36190, J36193**

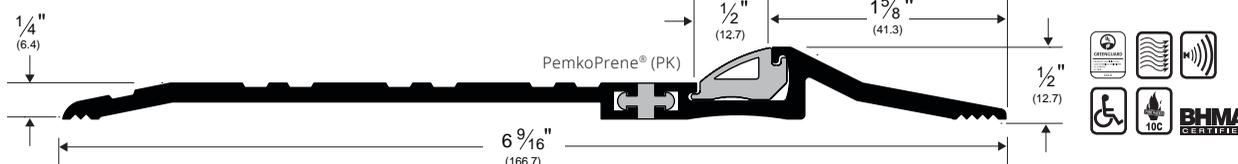

2746x292_FGPK

AVAILABLE FINISHES: **10BE, A, BSP, D, WSP**
 REPLACEMENT INSERT: **PK20 (BL)**
 ANSI (aluminum): **J35190, J35193, J36190, J36193**

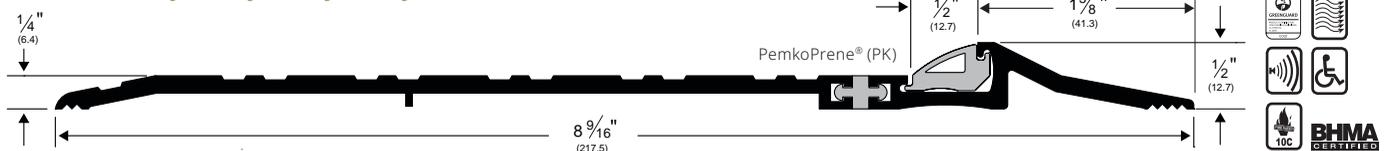

NOTE: Products shown in this section may not be drawn to scale.

AVAILABLE FINISHES FOR PRODUCTS SHOWN ON THIS PAGE
10BE (Satin Bronze Powder Coated Aluminum) **A** (Mill Finish Aluminum) **BSP** (Black Suede Powder Coated Aluminum)
D (Dark Bronze Anodized) **WSP** (White Suede Powder Coated Aluminum)

800-824-3018 | www.pemko.com

Check the web site for the up-to-date catalog

Copyright © 2015-2024, ASSA ABLOY Accessories and Door Controls Group, Inc., an ASSA ABLOY Group company. All rights reserved.
 Reproduction in whole or in part without the express written permission of ASSA ABLOY Accessories and Door Controls Group, Inc. is prohibited.

PEMKO
ASSA ABLOY

Experience a safer
 and more open world

ACOUSTIC THRESHOLDS

- Pemko's line of Acoustic Thresholds are designed to aid with a door's STC rating
- **2006STC** is only ADA compliant when installed butted to other flooring materials in accordance with ADA guidelines
- Thresholds will not improve a door's "sealed-in-place" STC rating
- See the Acoustic Catalog Section or visit Pemko's website, www.pemko.com, for more Acoustic products and additional information

2006STC_

AVAILABLE FINISHES: **10BE, A, BSP, D, WSP**
 REPLACEMENT INSERT: **T5 (BL)**
 ANSI (aluminum): **J36100, J36130**

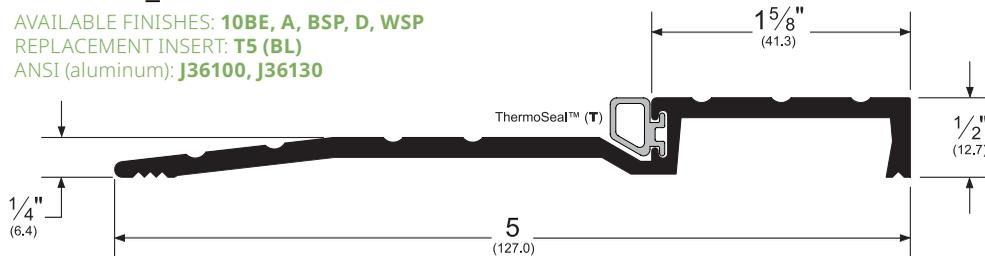

2008_PK

AVAILABLE FINISHES: **10BE, A, BSP, D, WSP**
 REPLACEMENT INSERT: **PK381 (BL)**
 ANSI (aluminum): **J36100, J36130**

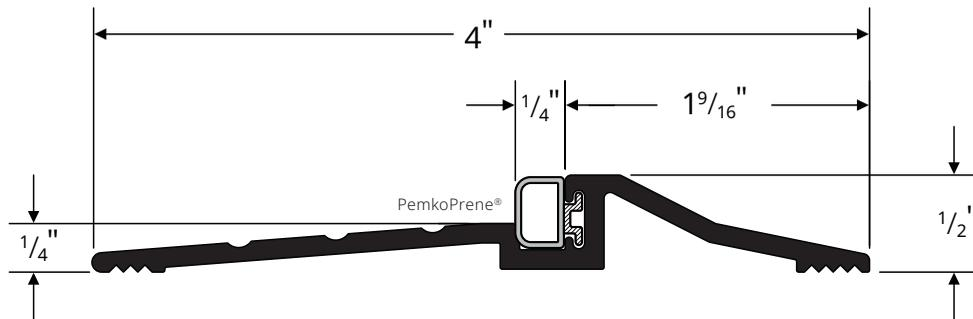

THRESHOLD WITH FLEXIBLE JOINT

- Flexible joint allows the threshold to flex as much as 20° up or down
- Expands up to an additional 1/4"

573x5_FG

AVAILABLE FINISHES: **A, D**
 REPLACEMENT INSERT: **PK45 (BL)**
 ANSI (aluminum): **J3219, J32190, J32193**

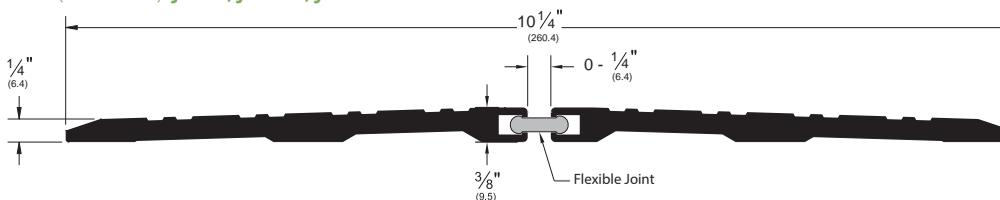

* When used in such a manner that the slope is not steeper than 1:2, and the overall height is 1/2" or less and all other criteria are met.



NOTE: Products shown in this section may not be drawn to scale.

AVAILABLE FINISHES FOR PRODUCTS SHOWN ON THIS PAGE

10BE (Satin Bronze Powder Coated Aluminum) **A** (Mill Finish Aluminum) **BSP** (Black Suede Powder Coated Aluminum) **D** (Dark Bronze Anodized) **WSP** (White Suede Powder Coated Aluminum)



Experience a safer and more open world

800-824-3018 | www.pemko.com
 Check the web site for the up-to-date catalog

Copyright © 2015-2024, ASSA ABLOY Accessories and Door Controls Group, Inc., an ASSA ABLOY Group company. All rights reserved. Reproduction in whole or in part without the express written permission of ASSA ABLOY Accessories and Door Controls Group, Inc. is prohibited.

CONCEALED FASTENER THRESHOLDS

- Material: 6063-T6 Aluminum Alloy and Temper
- Warranty: 5 years from purchase date

650

AVAILABLE FINISHES: **A, D**
ANSI: **J32100, J32130**

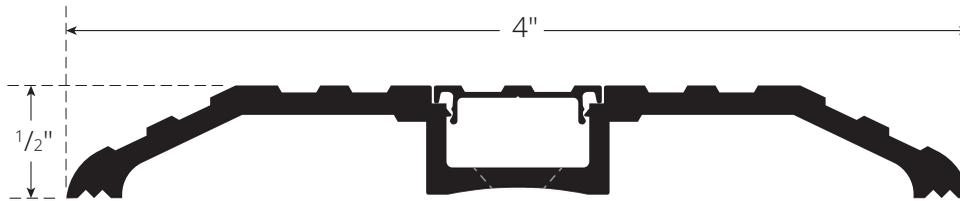

651

AVAILABLE FINISHES: **A, D**
ANSI: **J32100, J32130**

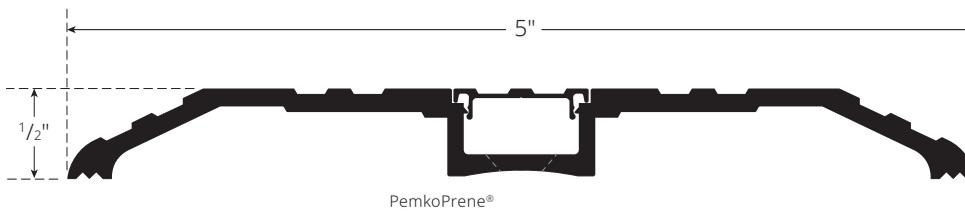

671

AVAILABLE FINISHES: **A, D**
ANSI: **J32100, J32130**

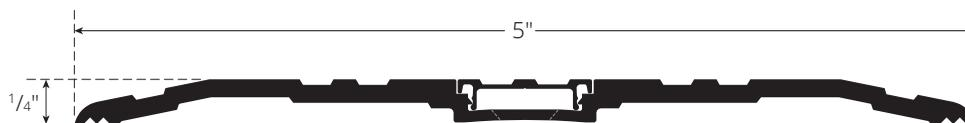

NOTE: Products shown in this section may not be drawn to scale.

AVAILABLE FINISHES FOR PRODUCTS SHOWN ON THIS PAGE
A (Mill Finish Aluminum) **D** (Dark Bronze Anodized)

800-824-3018 | www.pemko.com

Check the web site for the up-to-date catalog

Copyright © 2015-2024, ASSA ABLOY Accessories and Door Controls Group, Inc., an ASSA ABLOY Group company. All rights reserved.
Reproduction in whole or in part without the express written permission of ASSA ABLOY Accessories and Door Controls Group, Inc. is prohibited.

PEMKO
ASSA ABLOY

Experience a safer
and more open world

ECO-V™ THRESHOLDS

- Eco-V™ thresholds create an ideal transition where two different pieces of carpet meet, or carpet meets another surface under a door
- Ideal for use in any high-traffic commercial installation, such as hotels and offices
- Eco-V™ thresholds are manufactured from slightly softer material than competitive products. This aids in the cutting and fitting of the threshold and facilitates easier insertion of the carpet into the holding cavities on the carpet side(s) of the threshold
- Eco-V™ thresholds are designed to work in conjunction with Pemko's **2173_V**, **2113_V** and **2343_V** door shoes
- EV232**, **EV2325**, and **ADJ232V** thresholds meet the requirements outlined in **ADAAG-2010 (Amended)**; **ICC/ANSI A117.1** and **California Building Code, Title 24** for Barrier-Free Entry - 1/2" max rise above finished floor

EV232_

AVAILABLE COLORS: **BL, D**

AVAILABLE LENGTHS: **36", 48", 73"**

Serves as a transition where two pieces of carpet meet beneath an interior door

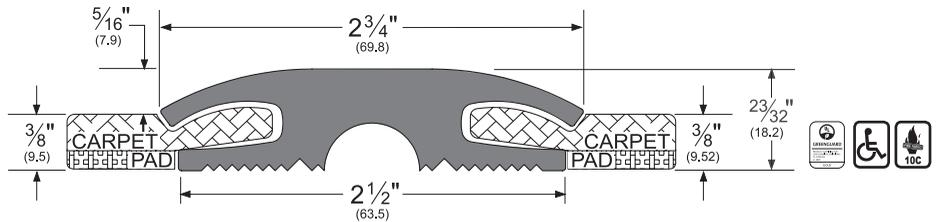

EV2325_

AVAILABLE COLORS: **BL, D**

AVAILABLE LENGTHS: **36", 48", 73"**

Serves as a transition where one piece of carpet meets tile beneath an interior door

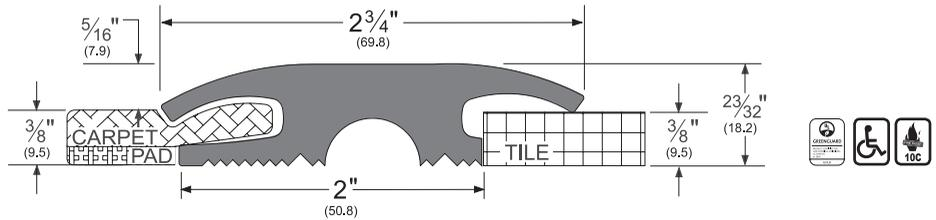

EV2326_

AVAILABLE COLORS: **BL, D**

AVAILABLE LENGTHS: **36", 48", 73"**

Serves as a transition where two pieces of tile meet beneath an interior door

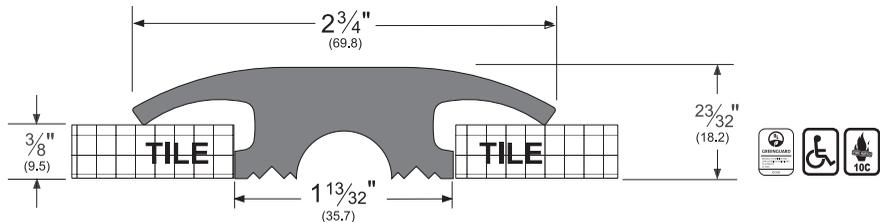

EV2320_

AVAILABLE COLOR: **BL**

AVAILABLE LENGTHS: **36", 48", 73"**

Serves as a transition where carpet meets concrete beneath an interior or exterior door

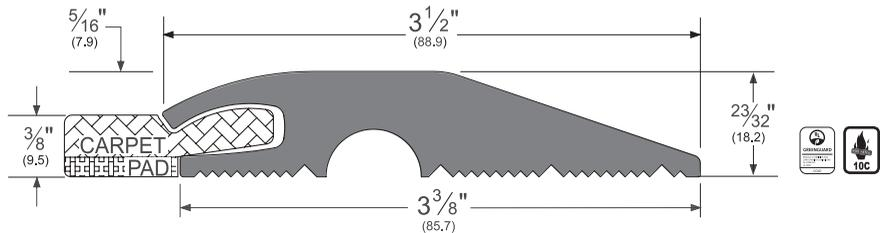

EV2322_

AVAILABLE COLOR: **BL**

AVAILABLE LENGTHS: **36", 48", 73"**

Serves as a transition where carpet meets 1/8" tile beneath an interior door

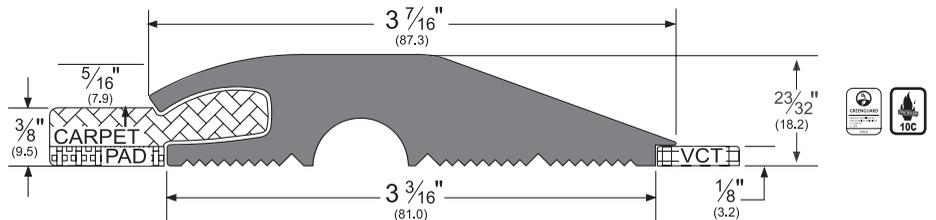

PEMKO
ASSA ABLOY

Experience a safer
and more open world

NOTE: Products shown in this section may not be drawn to scale.
AVAILABLE FINISHES FOR PRODUCTS SHOWN ON THIS PAGE
BL (Black) **D** (Dark Brown)

800-824-3018 | www.pemko.com
Check the web site for the up-to-date catalog

Copyright © 2015-2024, ASSA ABLOY Accessories and Door Controls Group, Inc., an ASSA ABLOY Group company. All rights reserved.
Reproduction in whole or in part without the express written permission of ASSA ABLOY Accessories and Door Controls Group, Inc. is prohibited.

ADJUSTABLE-WIDTH ECO-V™ THRESHOLD

- The adjustable-width threshold is designed for installations where the widths of the transition beneath a door may need to change, without completely disassembling and reinstalling the threshold
- The adjustable-width threshold consists of two Eco-V™ end pieces and one Eco-V™ adjustable center section
- Center section (**EV2321** below) can easily be cut to size with a standard razor knife

ADJ232V8_

AVAILABLE COLOR: **BL, D**
AVAILABLE LENGTHS: **36", 48"**

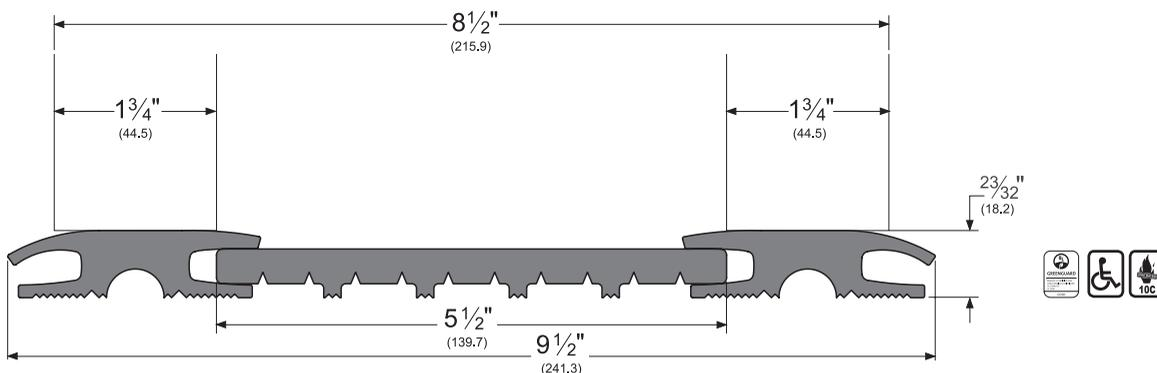

ADJ232V14_

AVAILABLE COLOR: **BL, D**
AVAILABLE LENGTHS: **36", 48"**

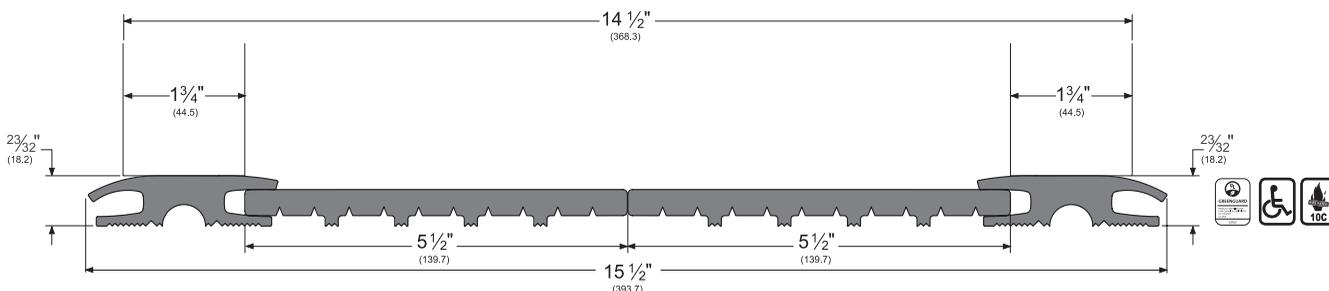

- Eco-V™ threshold ends can be used in many combinations to suit your flooring combination needs
- Shown below is **EV232** used with **EV2325** to illustrate use with carpet outside one communicating door and tile outside the other

ADJ232x2325V8_

AVAILABLE COLOR: **BL, D**
AVAILABLE LENGTHS: **36", 48", 73"**
Serves as a transition where carpet meets tile beneath an interior door

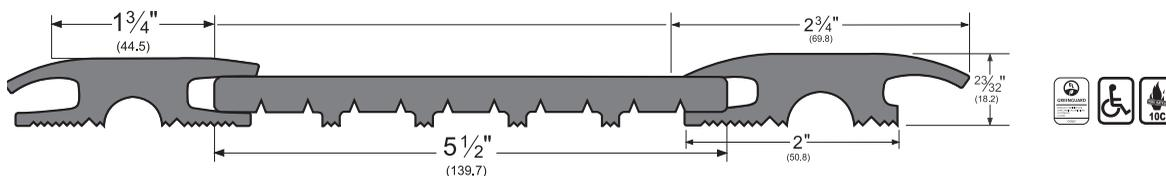

NOTE: Products shown in this section may not be drawn to scale.
AVAILABLE FINISHES FOR PRODUCTS SHOWN ON THIS PAGE
BL (Black) **D** (Dark Brown)

800-824-3018 | www.pemko.com
Check the web site for the up-to-date catalog

Copyright © 2015-2024, ASSA ABLOY Accessories and Door Controls Group, Inc., an ASSA ABLOY Group company. All rights reserved.
Reproduction in whole or in part without the express written permission of ASSA ABLOY Accessories and Door Controls Group, Inc. is prohibited.

PEMKO
ASSA ABLOY

Experience a safer
and more open world

HEAVY DUTY LATCHING PANIC EXIT SADDLE THRESHOLD

- Ideal for heavy-duty, high-traffic and high weight-bearing applications, such as industrial facilities, schools, cafeterias, manufacturing buildings and hospitals
- Withstands coastal and high-humidity conditions
- Ultra-durable, extra thick extruded nickel-aluminum construction is guaranteed for ten (10) years

2705_T

AVAILABLE FINISHES: **10BE, A, AK, BSP, D, WSP**
 ANSI (aluminum): **J35100, J35130, J36100, J36130**
 ANSI (alum w/PemKote): **J36200, J36130**

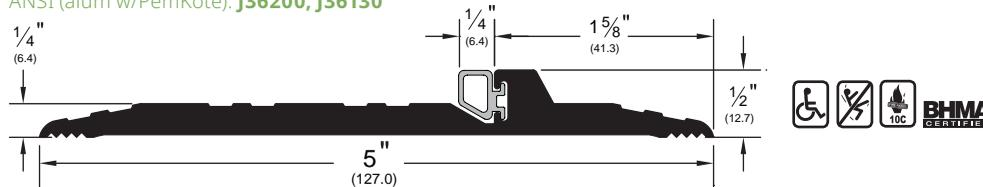

All items on this page are available with PemKote™ non-slip coating (see General Information section). Please specify "PemKote™" when ordering. Please furnish drilling instructions when ordering PemKote™ as it is difficult to drill through this coating.

HEAVY DUTY THRESHOLDS

- Ideal for heavy-duty, high-traffic and high weight-bearing applications, such as industrial facilities, schools, cafeterias, manufacturing buildings and hospitals
- Withstands coastal and high-humidity conditions
- Ultra-durable, extra thick extruded nickel-aluminum construction is guaranteed for ten (10) years

2715

AVAILABLE FINISHES: **10BE, A, AK, BSP, D, WSP**
 ANSI (aluminum): **J32100, J32130**
 ANSI (alum w/PemKote): **J32200, J32230**



All items on this page are available with PemKote™ non-slip coating (see General Information section). Please specify "PemKote™" when ordering. Please furnish drilling instructions when ordering PemKote™ as it is difficult to drill through this coating.

2716

AVAILABLE FINISHES: **10BE, A, AK, BSP, D, WSP**
 ANSI (aluminum): **J32100, J32130**
 ANSI (alum w/PemKote): **J32200, J32230**



1715_

AVAILABLE FINISHES: **10BE, A, AK, BSP, D, WSP**
 ANSI (aluminum): **J32100, J32130**
 ANSI (alum w/PemKote): **J32200, J32230**

Allow 5/8" door clearance



NOTE: Products shown in this section may not be drawn to scale.

AVAILABLE FINISHES FOR PRODUCTS SHOWN ON THIS PAGE

10BE (Satin Bronze Powder Coated Aluminum) **A** (Mill Finish Aluminum)

AK (Mill Finish Aluminum w/PemKote™ Non-Slip Coating) **BSP** (Black Suede Powder Coated Aluminum)

D (Dark Bronze Anodized) **WSP** (White Suede Powder Coated Aluminum)

NOTE: **D** is available with limited inventory

PEMKO
ASSA ABLOY

Experience a safer
 and more open world

800-824-3018 | www.pemko.com
 Check the web site for the up-to-date catalog

Copyright © 2015-2024, ASSA ABLOY Accessories and Door Controls Group, Inc., an ASSA ABLOY Group company. All rights reserved. Reproduction in whole or in part without the express written permission of ASSA ABLOY Accessories and Door Controls Group, Inc. is prohibited.

HEAVY DUTY THRESHOLDS (Cont.)

1716_

AVAILABLE FINISHES: **10BE, A, AK, BSP, D, WSP**

ANSI (aluminum): **J32100, J32130**

ANSI (alum w/PemKote): **J32200, J32230**

Allow $\frac{5}{8}$ " door clearance



All items on this page are available with PemKote™ non-slip coating (see General Information section). Please specify "PemKote™" when ordering. Please furnish drilling instructions when ordering PemKote™ as it is difficult to drill through this coating.

MODULAR HEAVY DUTY THRESHOLDS

- Modular construction allows threshold to fit openings up to 15" wide without the expense of custom cast thresholds. There is no restriction on width additions (in 1" increments)
- Modular Thresholds can be thermally broken. Order by adding "FG" to the part number and designate at which joint the thermal key should be supplied. Note that each thermal key will add $\frac{1}{8}$ " to overall width of threshold.

1717_

AVAILABLE FINISHES: **10BE, A, AK, BSP, D, WSP**

Allow $\frac{5}{8}$ " door clearance

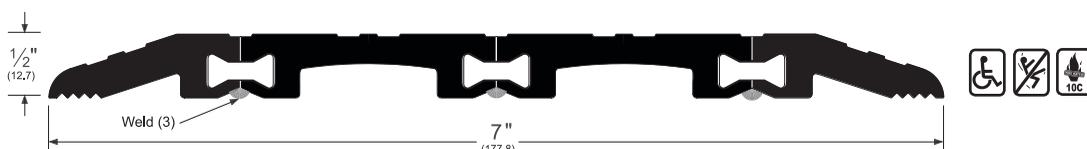

1718_

AVAILABLE FINISHES: **10BE, A, AK, BSP, D, WSP**

Allow $\frac{5}{8}$ " door clearance

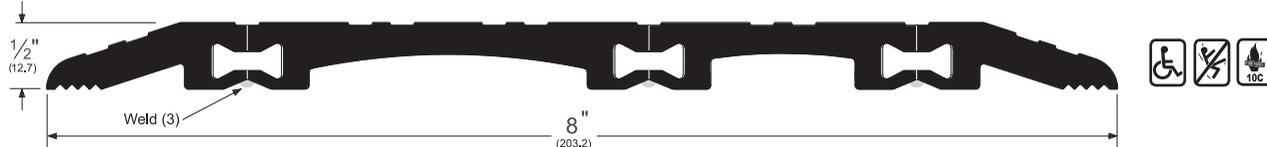

1719_

AVAILABLE FINISHES: **10BE, A, AK, BSP, D, WSP**

Allow $\frac{5}{8}$ " door clearance

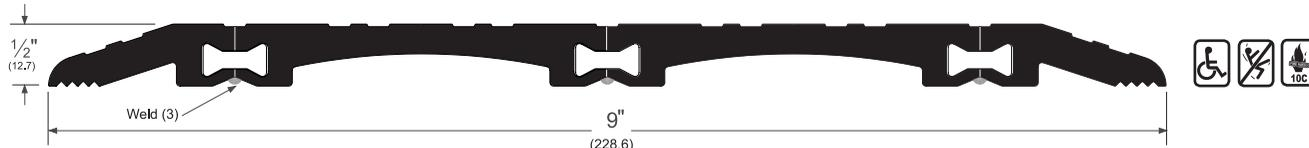

NOTE: Products shown in this section may not be drawn to scale.

AVAILABLE FINISHES FOR PRODUCTS SHOWN ON THIS PAGE

10BE (Satin Bronze Powder Coated Aluminum) **A** (Mill Finish Aluminum)

AK (Mill Finish Aluminum w/PemKote™ Non-Slip Coating) **BSP** (Black Suede Powder Coated Aluminum)

D (Dark Bronze Anodized) **WSP** (White Suede Powder Coated Aluminum)

NOTE: **D** is available with limited inventory

800-824-3018 | www.pemko.com

Check the web site for the up-to-date catalog

Copyright © 2015-2024, ASSA ABLOY Accessories and Door Controls Group, Inc., an ASSA ABLOY Group company. All rights reserved.

Reproduction in whole or in part without the express written permission of ASSA ABLOY Accessories and Door Controls Group, Inc. is prohibited.

PEM KO
ASSA ABLOY

Experience a safer
and more open world

FLOOR PLATES/SAFETY TREADS

- Pemko can fabricate almost any floor plate threshold you might require
- Furnished undrilled unless drilling instructions are specified when ordering
- Ordering of fasteners does not constitute drilling instructions
- Elevated floor plates require support every 4" on center, at welded seams, and as necessary for support
- Orders with "x" in the product number (i.e. 195 x 193 x 195) indicate welding



Available with PemKote™ non-slip coating (see General Information section). Please specify "PemKote™" when ordering. Please furnish drilling instructions when ordering PemKote™ as it is difficult to drill through this coating.

190_

AVAILABLE FINISHES: **10BE, A, BSP, D, WSP**
 ANSI (aluminum): **J37100, J37130**
 ANSI (brass): **J17100, J17130**

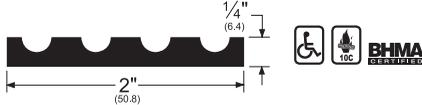

191_

AVAILABLE FINISHES: **10BE, A, BSP, D, WSP**
 ANSI (aluminum): **J37100, J37130**
 ANSI (brass): **J17100, J17130**

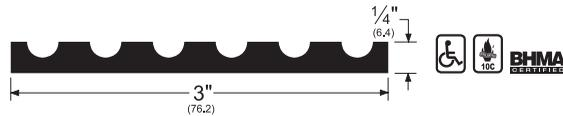

192_

AVAILABLE FINISHES: **10BE, A, BSP, D, WSP**
 ANSI (aluminum): **J37100, J37130**
 ANSI (brass): **J17100, J17130**

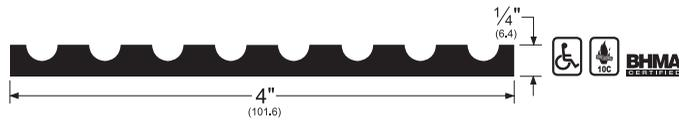

193_

AVAILABLE FINISHES: **10BE, A, BSP, D, WSP**
 ANSI (aluminum): **J37100, J37130**
 ANSI (brass): **J17100, J17130**

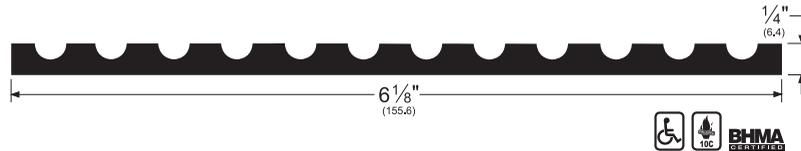

228_

AVAILABLE FINISHES: **10BE, A, BSP, D, WSP**
 ANSI (aluminum): **J37100, J37130**
 ANSI (brass): **J17100, J17130**

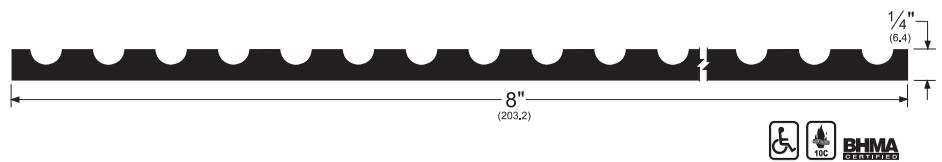

227_

AVAILABLE FINISHES: **10BE, A, BSP, D, WSP**
 ANSI (aluminum): **J33100, J33130**
 ANSI (brass): **J13100, J13130**

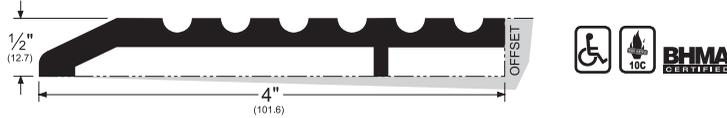

229_

AVAILABLE FINISHES: **10BE, A, BSP, D, WSP**
 ANSI (aluminum): **J33100, J33130**

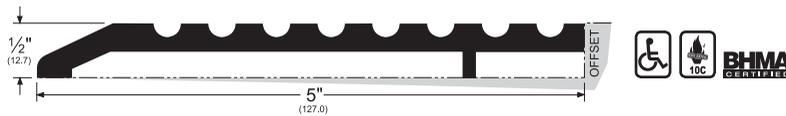

2266_

AVAILABLE FINISHES: **10BE, A, BSP, D, WSP**
 ANSI (aluminum): **J37100, J37130**

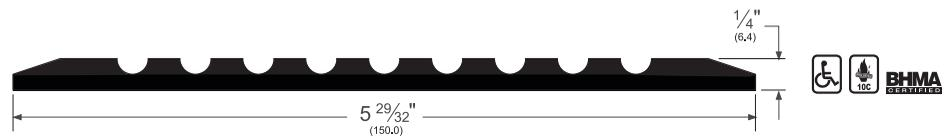

2286_

AVAILABLE FINISHES: **10BE, A, BSP, D, WSP**
 ANSI (aluminum): **J37100, J37130**

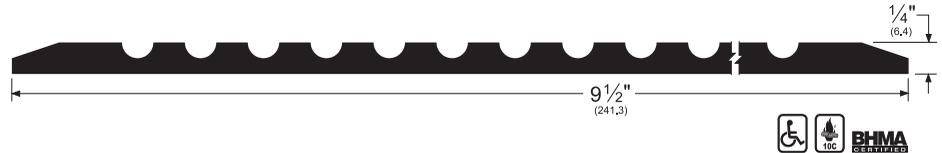

NOTE: Products shown in this section may not be drawn to scale.

AVAILABLE FINISHES FOR PRODUCTS SHOWN ON THIS PAGE
10BE (Satin Bronze Powder Coated Aluminum) **A** (Mill Finish Aluminum)
BSP (Black Suede Powder Coated Aluminum) **D** (Dark Bronze Anodized)
WSP (White Suede Powder Coated Aluminum)



Experience a safer and more open world

800-824-3018 | www.pemko.com
 Check the web site for the up-to-date catalog

Copyright © 2015-2024, ASSA ABLOY Accessories and Door Controls Group, Inc., an ASSA ABLOY Group company. All rights reserved. Reproduction in whole or in part without the express written permission of ASSA ABLOY Accessories and Door Controls Group, Inc. is prohibited.

FLOOR PLATES/SAFETY TREADS (Cont.)

19125_

AVAILABLE FINISHES: **10BE, A, AK, BSP, D, WSP**
ANSI (aluminum): **J37100, J37130**

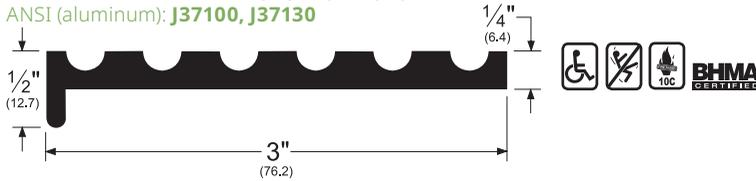

ALUMINUM PLATES

- Used where a cover plate, expansion joint plate, or wide extra-strength metal plate is needed
- Maximum length is 144". All aluminum plates are provided NET length
- Both length edges are beveled at a 45° angle; "single edge bevel" or "no bevel" is also available at no extra cost; length of plate should be roughly equal to width of opening.
- Plates are supplied undrilled unless otherwise specified. Pemko reserves the right to charge for special fastener patterns
- Plates are furnished with #10 x 1 1/2" wood screws. Screws supplied: one (1) screw per foot up to 8" wide; two (2) screws per foot 8" to 12" wide; and three (3) screws per foot over 12" wide
- Plates are ADA compliant only when ordered with PemKote finish



18/1_ - (width x length)

AVAILABLE FINISH: **10BE, A, AK, BSP, WSP**
ANSI (aluminum): **J37300, J37330**
ANSI (alum w/PemKote): **J37400, J37430**

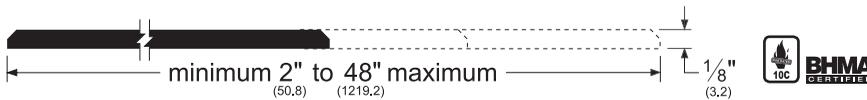

14/1_ - (width x length)

AVAILABLE FINISH: **10BE, A, AK, BSP, WSP**
ANSI (aluminum): **J37300, J37330**
ANSI (alum w/PemKote): **J37400, J37430**

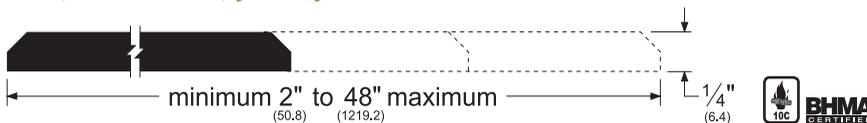

NOTE: Products shown in this section may not be drawn to scale.

AVAILABLE FINISHES FOR PRODUCTS SHOWN ON THIS PAGE
10BE (Satin Bronze Powder Coated Aluminum) **A** (Mill Finish Aluminum)
AK (Mill Finish Aluminum w/PemKote™ Non-Slip Coating) **BSP** (Black Suede Powder Coated Aluminum)
D (Dark Bronze Anodized) **WSP** (White Suede Powder Coated Aluminum)

NOTE: **D** is available with limited inventory

800-824-3018 | www.pemko.com

Check the web site for the up-to-date catalog

Copyright © 2015-2024, ASSA ABLOY Accessories and Door Controls Group, Inc., an ASSA ABLOY Group company. All rights reserved.
Reproduction in whole or in part without the express written permission of ASSA ABLOY Accessories and Door Controls Group, Inc. is prohibited.

PEMKO
ASSA ABLOY

Experience a safer
and more open world

CARPET SEPARATORS

174_

AVAILABLE FINISHES: **10BE, BSP, C, D, WSP**
 ANSI (aluminum): **J32300, J32340**
 ANSI (brass): **J17300, J17330**

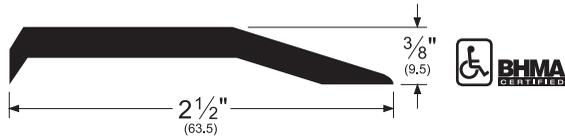

1951_

AVAILABLE FINISHES: **A, D**
 ANSI (aluminum): **J37300, J37330**
 • Supplied undrilled unless otherwise specified
 • ADA compliant when butted to 1/4" or 1/2" high flooring material

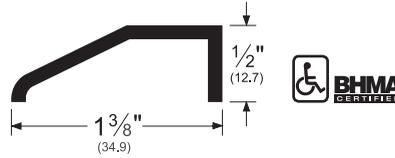

230_

AVAILABLE FINISHES: **10BE, A, BSP, D, WSP**

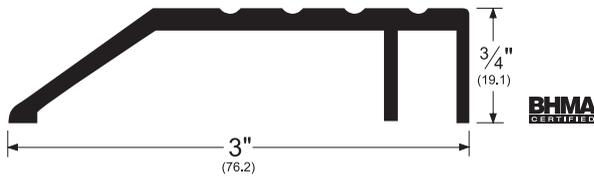

236_

AVAILABLE FINISHES: **10BE, A, BDG, BSP, D, WSP**
 ANSI (aluminum): **J32134**

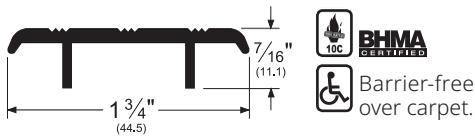

2364_

AVAILABLE FINISHES: **10BE, A, BSP, D, WSP**
 ANSI (aluminum): **J32134, J32140**



NOTE: Products shown in this section may not be drawn to scale.

AVAILABLE FINISHES FOR PRODUCTS SHOWN ON THIS PAGE
10BE (Satin Bronze Powder Coated Aluminum) **A** (Mill Finish Aluminum)
BSP (Black Suede Powder Coated Aluminum) **C** (Clear Anodized)
D (Dark Bronze Anodized) **WSP** (White Suede Powder Coated Aluminum)

PEMCO
ASSA ABLOY

Experience a safer
 and more open world

800-824-3018 | www.pemko.com
 Check the web site for the up-to-date catalog

Copyright © 2015-2024, ASSA ABLOY Accessories and Door Controls Group, Inc., an ASSA ABLOY Group company. All rights reserved.
 Reproduction in whole or in part without the express written permission of ASSA ABLOY Accessories and Door Controls Group, Inc. is prohibited.

FLOOR PLATE SUPPORTS/ACCESSORIES

- Please see information under Floor Plates and Safety Treads (page 134-135)

195_

AVAILABLE FINISHES: **10BE, A, BSP, D, WSP**
 ANSI (aluminum): **J37300**
 ANSI (brass): **J17300**

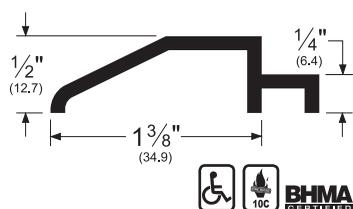

196_

AVAILABLE FINISHES: **10BE, A, B, BSP, D, WSP**
 ANSI (aluminum): **J37300, J37330**
 ANSI (brass): **J17300, J17330**

When ordering, specify whether 196 material is to be used as trim or support

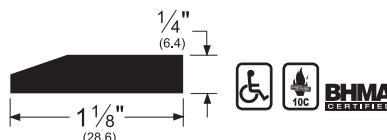

200_

AVAILABLE FINISHES: **10BE, A, BSP, D, WSP**
 ANSI (aluminum): **J37300, J37330**
 ANSI (brass): **J17300, J17330**

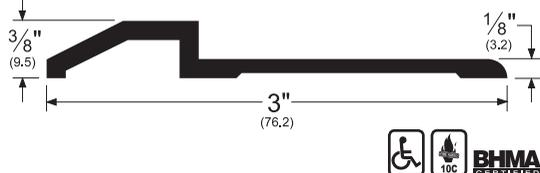

ELEVATORS

- Elevators allow for custom sizing in offset conditions
- Fasteners are not included and are not required with these shapes when used in conjunction with a threshold

183_

AVAILABLE FINISHES:
10BE, A, B, BSP, D, WSP

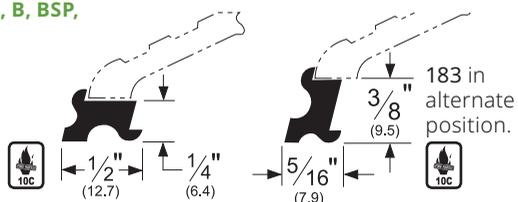

282_

AVAILABLE FINISHES:
10BE, A, BSP, D, WSP

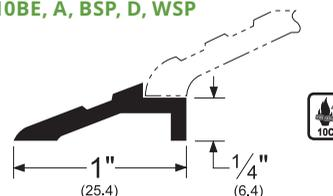

283_

AVAILABLE FINISHES:
10BE, A, B, BSP, D, WSP

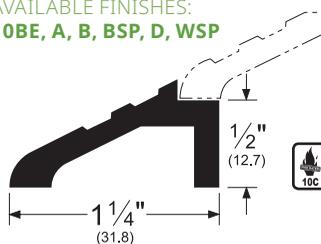

NOTE: Products shown in this section may not be drawn to scale.

AVAILABLE FINISHES FOR PRODUCTS SHOWN ON THIS PAGE
10BE (Satin Bronze Powder Coated Aluminum) **A** (Mill Finish Aluminum)
B (Mill Finish Extruded Bronze [Brass])
BSP (Black Suede Powder Coated Aluminum) **C** (Clear Anodized)
D (Dark Bronze Anodized) **WSP** (White Suede Powder Coated Aluminum)

800-824-3018 | www.pemko.com

Check the web site for the up-to-date catalog

Copyright © 2015-2024, ASSA ABLOY Accessories and Door Controls Group, Inc., an ASSA ABLOY Group company. All rights reserved.
 Reproduction in whole or in part without the express written permission of ASSA ABLOY Accessories and Door Controls Group, Inc. is prohibited.

PEMKO
ASSA ABLOY

Experience a safer
 and more open world

THRESHOLD STOP STRIPS

- Use with standard flat top, saddle threshold to provide a door stop and seal at bottom of door
- Stop strips are supplied pre-drilled with #10-24 Phillips flat head machine screws of appropriate length
- These stops will affect the pivot hole location of an assembly

1842_S

AVAILABLE FINISHES: **10BE, A, BSP, D, WSP**
 REPLACEMENT INSERT: **S3 (BL, W)**

- Allow 1/8" door clearance from top of threshold
- Barrier-free with 1/4" saddle only

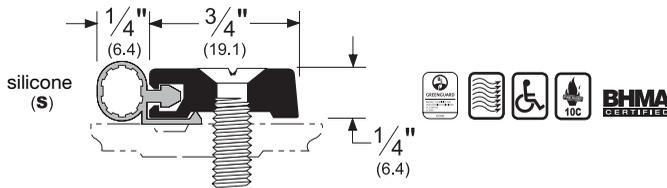

290_SSTOP

AVAILABLE FINISHES: **10BE, A, BSP, D, G, WSP**
 REPLACEMENT INSERT: **S3 (BL, W)**

- Allow 1/8" door clearance from top of threshold
- Barrier-free with 1/4" saddle only

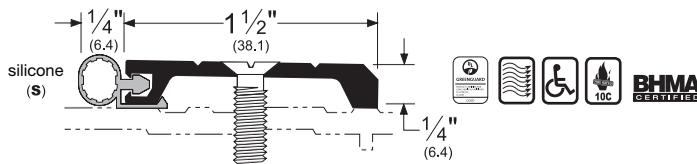

184_T

AVAILABLE FINISHES: **10BE, A, B, BSP, D, WSP**
 REPLACEMENT INSERT: **T5 (BL)**

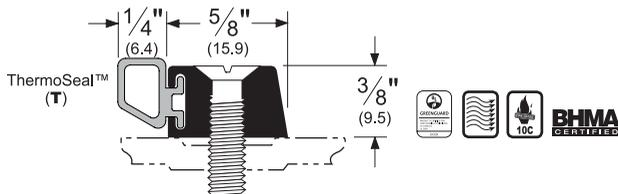

Alternate Inserts

1842_PK
290_PKSTOP

REPLACEMENT INSERT:
PK47 (BL, GR)

PemkoPrene™ (PK)

Alternate Inserts

1842_V
290_VSTOP

REPLACEMENT INSERT:
EV47 (BL, GR, W)

Eco-V™ (V)

Alternate Inserts

184_P

REPLACEMENT INSERT:
P2 (BL, GR)

pile (P)

Alternate Inserts

184_V

REPLACEMENT INSERT:
EV41 (BL, GR, W)

Eco-V™ (V)

NOTE: Products shown in this section may not be drawn to scale.

AVAILABLE FINISHES FOR PRODUCTS SHOWN ON THIS PAGE

10BE (Satin Bronze Powder Coated Aluminum) **A** (Mill Finish Aluminum) **B** (Mill Finish Extruded Bronze [Brass])
BSP (Black Suede Powder Coated Aluminum) **D** (Dark Bronze Anodized) **G** (Gold Anodized)
WSP (White Suede Powder Coated Aluminum)

NOTE: **G** is available with limited inventory



Experience a safer
 and more open world

FLOOR CLOSER THRESHOLDS/COVER PLATE ASSEMBLIES

- **TYPE OF ASSEMBLY** – Type 11 or 14 for center hung, Type 13 or 15 for offset hung
- **MATERIALS** – Saddles, floor plates, supports, risers, elevators, and stop strips
- **CLOSER TO BE USED** – Manufacturer and model number
- **NET LENGTH** – Jamb-to-jamb. Assembly Types 11, 13 and 14 are cut with center section $\frac{1}{2}$ " over net length up to 48" and 1" over net length over 48" to allow for fitting on the job. Please specify "net length", if required. Assembly Type 15 is cut at net length because of factory-cut miters
- **HANDING** – For single doors, specify right or left hand. For pairs of doors, handing is not required
- **SPECIAL FINISHES** – Examples include polished, oxidized and oil rubbed, and PemKote™
- **SPECIAL FASTENERS** – For center section only. Examples include: MSES, FHSL25, and MSES-SS
- **SPECIAL FABRICATION INSTRUCTIONS** – Notching, full miters, etc. Assembly Type 11 is supplied without mitered ends, and assembly Types 13, 14 and 15 are supplied with both ends mitered. Also, when ordering stop strips (shown on page 132), specify door thickness and pivot offset so that the threshold assembly width and pivot dimension can be determined
- **RETURNS AND ALLOWANCES** – Restock fee for "custom" material applies to these products



THRESHOLD WIDTH	FASTENER ROWS	THRESHOLD WIDTH	FASTENER ROWS
2" to 7 $\frac{7}{8}$ "	1 Row	19" to 24 $\frac{7}{8}$ "	4 Rows
8" to 12 $\frac{7}{8}$ "	2 Rows	25" to 30 $\frac{7}{8}$ "	5 Rows
13" to 18 $\frac{7}{8}$ "	3 Rows	31" to 36 $\frac{7}{8}$ "	6 Rows

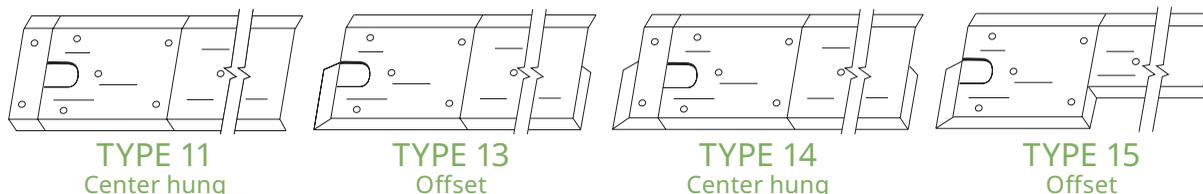

THRESHOLDS FOR TYPE 11, 13, 14				
SIZE	PRODUCT NUMBER	FINISHES	PRODUCT NUMBER	FINISHES
$\frac{1}{2}$ " x 7"	176_	A, B, D, G		
$\frac{1}{4}$ " x 7"	276_	A, B, D, G		
$\frac{1}{2}$ " x 8"	2548_	A, D, G	254_ x 4_	B
$\frac{1}{4}$ " x 8"	2748_	A, D, G	274_ x 4_	B
$\frac{1}{2}$ " x 8 $\frac{7}{8}$ "	193_ x 2/195_	A, D, G		
* $\frac{3}{4}$ " x 12" x $\frac{1}{4}$ "	257_ x 259_	A, B, D, G		

* Ramp threshold for $\frac{1}{2}$ " offset.

THRESHOLDS FOR TYPE 11, 13, 14	
Pemko	Rixson
Type 11	Type 1
Type 13	Type 3
Type 14	Type 4
Type 15	Type 5

THRESHOLDS FOR TYPE 15				
SIZE	PRODUCT NUMBER	FINISHES	PRODUCT NUMBER	FINISHES
$\frac{1}{2}$ " x 7" x 4"	176_ x 170_	A, B, D, G		
$\frac{1}{4}$ " x 7" x 4"	276_ x 270_	A, B, D, G		
$\frac{1}{2}$ " x 7" x 5"	176_ x 171_	A, B, D, G		
$\frac{1}{4}$ " x 7" x 5"	276_ x 271_	A, B, D, G		
$\frac{1}{2}$ " x 8" x 4"	2548_ x 170_	A, D, G	254 x 4_ x 170_	B
$\frac{1}{4}$ " x 8" x 4"	2748_ x 270_	A, D, G	274 x 4_ x 270_	B
$\frac{1}{2}$ " x 8" x 5"	2548_ x 171_	A, D, G	254 x 4_ x 171_	B
$\frac{1}{4}$ " x 8" x 5"	2748_ x 271	A, D, G	274 x 4_ x 271_	B

NOTE: Products shown in this section may not be drawn to scale.

AVAILABLE FINISHES FOR PRODUCTS SHOWN ON THIS PAGE

A (Mill Finish Aluminum) B (Mill Finish Extruded Bronze [Brass]) D (Dark Bronze Anodized) G (Gold Anodized)

NOTE: G is available with limited inventory

800-824-3018 | www.pemko.com

Check the web site for the up-to-date catalog

Copyright © 2015-2024, ASSA ABLOY Accessories and Door Controls Group, Inc., an ASSA ABLOY Group company. All rights reserved.

Reproduction in whole or in part without the express written permission of ASSA ABLOY Accessories and Door Controls Group, Inc. is prohibited.



Experience a safer and more open world

ANSI/BHMA A156.21 THRESHOLDS - CROSS REFERENCE

- Following a profile number, **"A"** signifies the base metal as aluminum and will include any anodized finish
- Following a profile number, **"B"** signifies the base metal as architectural bronze [brass]
- Consult www.buildershardware.com for the most up-to-date BHMA Certified Product Directory (CPD) information

ANSI No.	Pemko Item#
J12100	170B, 171B, 172B, 176B, 198B, 254x4B, 254x5B, 255x5B, 270B, 271B, 272B, 274x4B, 276B
J12130	170B, 171B, 172B, 176B, 254x4B, 254x5B, 255x5B, 270B, 271B, 272B, 274x4B, 276B
J12134	236B, 2364B
J12139	252x2BFG, 252x3BFG, 253x3BFG, 253x4BFG, 254x4BFG, 254x5BFG, 255x5BFG, 273x3BFG, 273x4BFG, 274x4BFG
J12190	252x2BFG, 252x3BFG, 253x3BFG, 253x4BFG, 254x4BFG, 254x5BFG, 255x5BFG, 273x3BFG, 273x4BFG, 274x4BFG
J12193	252x2BFG, 252x3BFG, 253x3BFG, 253x4BFG, 254x4BFG, 254x5BFG, 273x3BFG, 273x4BFG, 274x4BFG
J12300	151B, 173B, 175B
J12330	151B, 173B, 175B
J13100	227B, 252B, 253B, 254B, 255B, 273B, 274B
J13130	227B, 252B, 253B, 254B, 255B, 273B, 274B
J13133	273B, 274B
J14170	101B, 108B, 114B
J15100	177B, 181B, 2005B, 252x226B, 253x226B, 254x226B, 255x226B
J15130	2005B
J15190	252x226BFG, 253x226BFG, 254x226BFG, 255x226BFG
J15300	159B
J16100	177BT, 181BT, 2005B, 2005BT, 252x226BT, 253x226BT, 254x226BT, 255x226BT
J16130	2005B
J16300	159BT
J17300	174B, 195B, 196B, 200B
J17330	174B, 195B, 196B, 200B
J18130	257B, 259B, 275x259B
J19100	176B, 254x4B, 257B/259B, 274x4B, 276B
J19130	176B, 254x4B, 257B/259B, 274x4B, 276B
J19135	176B, 176B, 176Bx170B, 176Bx171B, 254x4B, 254x4B, 254x4Bx170B, 254x4Bx171B, 257B/259B, 257B/259B, 274x4B, 274x4B, 274x4Bx270B, 274x4Bx271B, 276B, 276B, 276Bx270B, 276Bx271B
J19150	176B, 176B, 176Bx170B, 176Bx171B, 254x4B, 254x4Bx170B, 254x4Bx171B, 257B/259B, 274x4B, 274x4B, 274x4Bx270B, 274x4Bx271B, 276B, 276B, 276Bx270B, 276Bx271B
J31100	206AV, 207AV
J32100	156A, 1571A, 157A, 158A, 166A, 169A, 1700A, 170A, 1715A, 171A, 172A, 176A, 182A, 198A, 2548A, 2549A, 2550A, 2555x253A, 256x6A, 256x6A, 270A, 2715A, 2716A, 271A, 2727A, 272A, 2746x6A, 2748A, 2749A, 2750A, 276A



Experience a safer
and more open world

800-824-3018 | www.pemko.com
Check the web site for the up-to-date catalog

Copyright © 2015-2024, ASSA ABLOY Accessories and Door Controls Group, Inc., an ASSA ABLOY Group company. All rights reserved.
Reproduction in whole or in part without the express written permission of ASSA ABLOY Accessories and Door Controls Group, Inc. is prohibited.

ANSI/BHMA A156.21 THRESHOLDS - CROSS REFERENCE (Cont.)

ANSI No.	Pemko Item#
J32130	158A, 166A, 169A, 1700A, 1701A, 1715A, 1716A, 1716A, 171A, 172A, 176A, 2548A, 2549A, 2550A, 2555x253A, 256x6A, 256x6A, 270A, 2715A, 2716A, 271A, 2727A, 272A, 2746x6A, 2748A, 2749A, 2750A, 276A
J32134	236A, 2364A, 2366A
J32138	158A, 2727A
J32139	252x2AFG, 252x3AFG, 253x3AFG, 253x4AFG, 253x6AFG, 254x4AFG, 254x5AFG, 2555x253AFG, 255x5AFG, 256x6AFG, 273x3AFG, 273x4AFG, 2746x6AFG, 274x4AFG
J32140	236A
J32180	157A, 1571A, 158A, 182A, 2727A
J32190	252x2AFG, 252x3AFG, 253x3AFG, 253x4AFG, 253x6AFG, 254x4AFG, 254x5AFG, 2555x253AFG, 255x5AFG, 256x6AFG, 273x3AFG, 273x4AFG, 2746x6AFG, 274x4AFG
J32193	252x2AFG, 252x3AFG, 253x3AFG, 253x4AFG, 253x6AFG, 254x4AFG, 254x5AFG, 2555x253AFG, 255x5AFG, 256x6AFG, 273x3AFG, 273x4AFG, 2746x6AFG, 274x4AFG
J32200	1715AK, 2715AK, 2716AK
J32230	1715AK, 1716AK, 2715AK, 2716AK
J32300	151A, 1546A, 1547A, 154A, 173A, 174A, 175A
J32330	151A, 1546A, 1547A, 154A, 173A, 174A, 175A
J33100	157A, 1571A, 182A, 1875A, 1877A, 227A, 229A, 252A, 253A, 254A, 2555A, 255A, 2565A, 256A, 273A, 2746A, 274A, 278A, 279A
J33130	227A, 229A, 252A, 253A, 254A, 255A, 2565A, 256A, 273A, 2746A, 274A, 278A, 279A
J33133	273A, 2746A, 274A, 278A, 279A
J33180	1875A, 1877A
J34170	101A, 107A, 114A, 121A, 123A
J35100	177A, 179A, 181A, 2005A, 2006A, 2008A, 252x226A, 253x226A, 254x226A, 255x226A, 2705A, 277A
J35130	2005A, 206A, 2008A, 2705A
J35190	252x226AFG, 253x226AFG, 254x226AFG, 255x226AFG
J35300	159A, 185A, 1855A
J36100	177AT, 179AT, 181AT, 2005AT, 2006AT, 2006STC, 2007AT, 2008APK, 2009APK, 2010APK, 252x226A, 252x266A, 253x226A, 254x226AT, 255x226AT, 2705A, 277AR, 277AS
J36130	2005A, 2005AT, 2006AT, 2006STC, 2008APK, 2009APK, 2010APK, 2705A, 273x224AFG, 273x292AFG, 2746x292AFG, 274x224AFG, 274x292AFG, 278x224AFG, 278x292AFG, 279x224AFG, 279x292AFG
J36139	273x224AFG, 273x292AFG, 2746x292AFG, 274x224AFG, 274x292AFG, 278x224AFG, 278x292AFG, 279x224AFG, 279x292AFG
J36190	252x226AFGT, 253x226AFG, 253x226BFG, 254x226AFG, 255x226AFG, 273x224AFG, 273x292AFG, 2746x292AFG, 274x224AFG, 274x292AFG, 278x224AFG, 278x292AFG, 279x224AFG, 279x292AFG
J36193	273x224AFG, 273x292AFG, 2746x292AFG, 274x224AFG, 274x292AFG, 278x224AFG, 278x292AFG, 279x224AFG, 279x292AFG
J36200	2705AK
J36230	2705AK

ANSI/BHMA A156.21 THRESHOLDS - CROSS REFERENCE (Cont.)

ANSI No.	Pemko Item#
J36300	159AT, 185AT, 1855AT
J37100	190A, 191A, 192A, 193A, 228A, 2266A, 2286A, 19125A
J37130	190A, 191A, 192A, 193A, 228A, 2266A, 2286A, 19125A
J37200	190AK, 191AK, 192AK, 193AK, 19125AK
J37230	190AK, 191AK, 192AK, 193AK, 19125AK
J37300	14/1A, 18/1A, 194A, 1951A, 195A, 196A, 200A
J37330	14/1A, 174C, 18/1A, 1951A, 195A, 196A, 200A
J37400	14/1A, 18/1A
J37430	14/1A, 18/1A
J38130	257A, 259A, 257x259A, RAMP10A, RAMP11A, RAMP12A, RAMP1A, RAMP2A, RAMP3A, RAMP4A, RAMP5A, RAMP6A, RAMP7A, RAMP8A, RAMP9A, WING10, WING16, WINGEXT
J38230	257AK, 259AK, 257x259AK, 257x259BK, RAMP10AK, RAMP11AK, RAMP12AK, RAMP1AK, RAMP2AK, RAMP3AK, RAMP4AK, RAMP5AK, RAMP6AK, RAMP7AK, RAMP8AK, RAMP9AK, WING10K, WING16K, WINGEXT
J39100	176A, 193Ax2/195A, 2548A, 257Ax259A, 2748A, 276A, RAMP1A
J39130	176A, 193Ax2/195A, 2548A, 257Ax259A, 2748A, 276A, RAMP1A
J39135	176A, 176Ax170A, 176Ax171A, 2548A, 2548Ax170A, 2548Ax171A, 257Ax259A, 2748A, 2748Ax270A, 2748Ax271A, 276A, 276Ax270A, 276Ax271A, RAMP1A
J39150	176A, 176Ax170A, 176Ax171A, 2548A, 2548Ax170A, 2548Ax171A, 257Ax259A, 2748A, 2748Ax270A, 2748Ax271A, 276A, 276Ax270A, 276Ax271A, RAMP1A
J52300	154SS, 158SS, 175SS
J52330	154SS, 175SS, 252x2SSFG, 252x3SSFG, 252x4SSFG, 253x3SSFG, 253x4SSFG, 254x4SSFG
J52338	158SS
J52339	252x2SSFG, 252x3SSFG, 252x4SSFG, 253x3SSFG, 253x4SSFG, 254x4SSFG
J52380	158SS
J52390	252x2SSFG, 252x3SSFG, 252x4SSFG, 253x3SSFG, 253x4SSFG, 254x4SSFG
J52393	252x2SSFG, 252x3SSFG, 252x4SSFG, 253x3SSFG, 253x4SSFG, 254x4SSFG
J53300	252SS, 253SS, 254SS
J53330	252SS, 253SS, 254SS
J53300	252SS, 253SS, 254SS
J53330	252SS, 253SS, 254SS

PEMKO MODULAR RAMPS

CONTENTS:

Ramp Ordering Information.....	120
Modular Ramp Threshold Assemblies - Flush Applications.....	121
Modular Ramp Threshold Assemblies - Offset (7" Top Plate).....	122
Modular Ramp Threshold Assemblies - Offset (3½" Top Plate)	123
Modular Ramp Threshold Components	124
Modular Ramp Threshold Assemblies - Variables	125
Risers for Modular Ramps.....	125
Miter Returns For All Modular Ramp Thresholds	126
Barrier-Free Ramp Thresholds.....	127
Fire Retardant and Styrene Butadiene Rubber Ramp Thresholds.....	128
Recycled Rubber Ramp Assembly.....	129

INDEX:

PRODUCT	PAGE	PRODUCT	PAGE	PRODUCT	PAGE
257	127	R1OSSMR.....	123	RAMP 6.....	124
257x259.....	127	R2.25F.....	121	RAMP 7.....	125
259	127	R2.25FMR	121	RAMP 8.....	124
R1.5F	121	R2F	121	RAMP 8.....	125
R1.5FMR.....	121	R2FMR	121	RAMP 9.....	124
R1.5OS.....	122	R2OS.....	122	RAMP 10.....	124
R1.5OSMR.....	122	R2OSMR.....	122	RAMP 11.....	124
R1.5OSS.....	123	R2OSS.....	123	RAMP 12.....	124
R1.5OSSMR.....	123	R2OSSMR.....	123	RAMP 13.....	125
R1.25F.....	121	R.5F	121	RAMP 14.....	125
R1.25FMR.....	121	R.5FMR	121	RR1	128
R1.25OS	122	R.5OS.....	122	RR1.25FMR.....	129
R1.25OSMR.....	122	R.5OSMR.....	122	RR2.....	128
R1.25OSS.....	123	R.5OSS.....	123	RVAR1/A	125
R1.25OSSMR.....	123	R.5OSSMR	123	RVAR1/AK.....	125
R1.75F.....	121	R.75F	121	RVARIOSS	125
R1.75FMR.....	121	R.75FMR.....	121	SBR1F.....	128
R1.75OS.....	122	R.75OS.....	122	SBR1FMR.....	128
R1.75OSMR.....	122	R.75OSMR.....	122	SBR.5F	128
R1.75OSS.....	123	R.75OSS	123	SBR.5FMR	128
R1.75OSSMR.....	123	R.75OSSMR	123	WING 10_H.....	126
R1F.....	121	RAMP 1.....	124	WING 16_H.....	126
R1FMR.....	121	RAMP 2.....	125	WING EXT_H	126
R1OS	122	RAMP 3.....	124		
R1OSMR	122	RAMP 4.....	124		
R1OSS.....	123	RAMP 5.....	124		

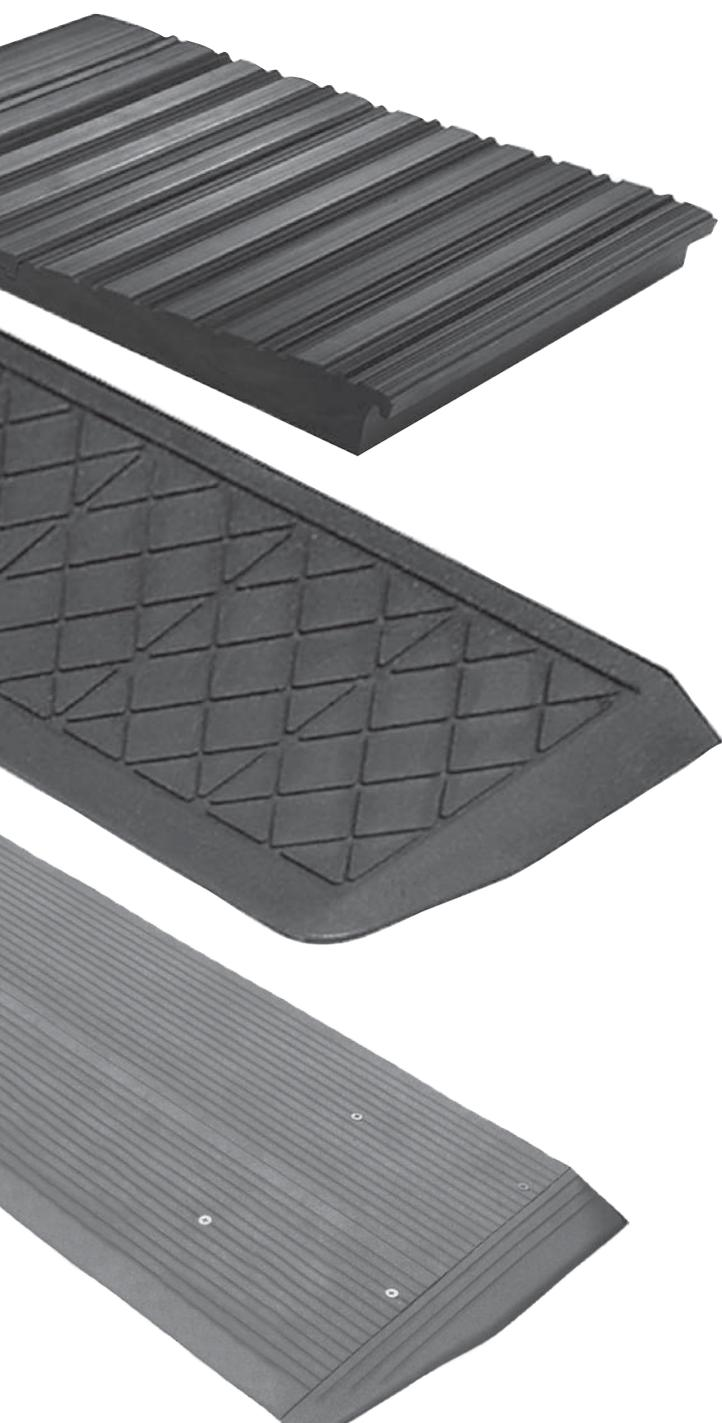

800-824-3018 | www.pemko.com
 Check the web site for the up-to-date catalog

Copyright © 2015-2024, ASSA ABLOY Accessories and Door Controls Group, Inc., an ASSA ABLOY Group company. All rights reserved.
 Reproduction in whole or in part without the express written permission of ASSA ABLOY Accessories and Door Controls Group, Inc. is prohibited.



Experience a safer
 and more open world

RAMP ORDERING INFORMATION

Flush Applications

Example: R 1 F MR AK

Product	Floor Offset Height	Application	Option	Finish
R = Ramp	.5 = ½" .75 = ¾" 1 = 1" 1.25 = 1-¼" 1.5 = 1-½" 1.75 = 1-¾" 2 = 2" 2.25 = 2-¼"	F = Flushes out to floor offset	MR = Miter Return (1 pair)	A = Aluminum (mill finish) AK = PemKote™ (skid-resistant surface)

Offset Applications - 7" Top Plate

Example: R 1 OS MR AK

Product	Floor Offset Height	Application	Option	Finish
R = Ramp	.5 = ½" .75 = ¾" 1 = 1" 1.25 = 1-¼" 1.5 = 1-½" 1.75 = 1-¾" 2 = 2"	OS = Up & over offset w/ 7" top plate	MR = Miter Return (1 pair)	A = Aluminum (mill finish) AK = PemKote™ (skid-resistant surface)

Offset Applications - 3½" Top Plate

Example: R 2 OSS MR AK

Product	Floor Offset Height	Application	Option	Finish
R = Ramp	.5 = ½" .75 = ¾" 1 = 1" 1.25 = 1-¼" 1.5 = 1-½" 1.75 = 1-¾" 2 = 2"	OSS = Up & over offset w/ 3-½" top plate	MR = Miter Return (1 pair)	A = Aluminum (mill finish) AK = PemKote™ (skid-resistant surface)



Experience a safer and more open world

800-824-3018 | www.pemko.com
Check the web site for the up-to-date catalog

MODULAR RAMP THRESHOLD ASSEMBLIES

- Assemblies accommodate 1/2" to 2 1/4" floor offsets in meeting the 1:12 slope requirements of the "Americans with Disabilities Act". Even higher offsets can be accommodated by using the risers, **RAMP13_** and **RAMP14_**
- "MR" in a product number denotes that one-pair of miter returns (and extenders, if applicable) is included. Otherwise, we recommend filling and feathering the threshold ends with grout. Do not leave threshold ends open
- Miter Returns are available for offsets up to 2 1/4"

- Assemblies are supplied with #10 stainless steel wood screws. Stainless steel machine screws and expansion shields are available at an extra cost
- Assemblies allow for custom fabrication; please consult Pemko Customer Service
- Assemblies are provided NET length
- Miter returns will add 2 pieces to total components; miter returns with extenders will add 4 pieces to total components

Flush Applications

1/2" Floor Offset



R.5F_ AVAILABLE FINISHES: **10BE, A, AK, BSP, WSP**
R.5FMR_ ** ASSEMBLY LENGTH: 6 1/8"
 # OF COMPONENTS: 1

PemKote™ is highly recommended for all threshold assemblies, especially exterior conditions where moisture may be present. Only with PemKote™ Non-Slip Coating



3/4" Floor Offset



R.75F_ AVAILABLE FINISHES: **10BE, A, AK, BSP, WSP**
R.75FMR_ ** ASSEMBLY LENGTH: 9 1/4"
 # OF COMPONENTS: 2



1" Floor Offset



R1F_ AVAILABLE FINISHES: **10BE, A, AK, BSP, WSP**
R1FMR_ ** ASSEMBLY LENGTH: 12 3/8"
 # OF COMPONENTS: 2



1 1/4" Floor Offset



R1.25F_ AVAILABLE FINISHES: **10BE, A, AK, BSP, WSP**
R1.25FMR_ ** ASSEMBLY LENGTH: 15 1/2"
 # OF COMPONENTS: 3



1 1/2" Floor Offset



R1.5F_ AVAILABLE FINISHES: **10BE, A, AK, BSP, WSP**
R1.5FMR_ ** ASSEMBLY LENGTH: 18 5/8"
 # OF COMPONENTS: 3



1 3/4" Floor Offset



R1.75F_ AVAILABLE FINISHES: **10BE, A, AK, BSP, WSP**
R1.75FMR_ ** ASSEMBLY LENGTH: 21 3/4"
 # OF COMPONENTS: 4



2" Floor Offset



R2F_ AVAILABLE FINISHES: **10BE, A, AK, BSP, WSP**
R2FMR_ ** ASSEMBLY LENGTH: 24 7/8"
 # OF COMPONENTS: 4



2 1/4" Floor Offset



R2.25F_ AVAILABLE FINISHES: **10BE, A, AK, BSP, WSP**
R2.25FMR_ ** ASSEMBLY LENGTH: 28"
 # OF COMPONENTS: 5



Complete assembly drawings available online
 NOTE: Greater offset may be accomplished by using Pemko risers.
 **Miter Returns are not ADA Compliant

AVAILABLE FINISHES FOR PRODUCTS SHOWN ON THIS PAGE
10BE (Satin Bronze Powder Coated Aluminum) **A** (Mill Finish Aluminum) **AK** (Mill Finish Aluminum with PemKote™ Non-Slip Coating) **BSP** (Black Suede Powder Coated Aluminum) **WSP** (White Suede Powder Coated Aluminum)

800-824-3018 | www.pemko.com

Check the web site for the up-to-date catalog

Copyright © 2015-2024, ASSA ABLOY Accessories and Door Controls Group, Inc., an ASSA ABLOY Group company. All rights reserved.
 Reproduction in whole or in part without the express written permission of ASSA ABLOY Accessories and Door Controls Group, Inc. is prohibited.



Experience a safer and more open world

OFFSET APPLICATIONS (7" TOP PLATE)

1/2" Floor Offset



R.5OS_

AVAILABLE FINISHES: **10BE, A, AK, BSP, WSP**

R.5OSMR_ **

ASSEMBLY LENGTH*: 16 1/4"

OF COMPONENTS: 3



3/4" Floor Offset



R.75OS_

AVAILABLE FINISHES: **10BE, A, AK, BSP, WSP**

R.75OSMR_ **

ASSEMBLY LENGTH*: 19 3/8"

OF COMPONENTS: 3



1" Floor Offset



R1OS_

AVAILABLE FINISHES: **10BE, A, AK, BSP, WSP**

R1OSMR_ **

ASSEMBLY LENGTH*: 22 1/2"

OF COMPONENTS: 4



1 1/4" Floor Offset



R1.25OS_

AVAILABLE FINISHES: **10BE, A, AK, BSP, WSP**

R1.25OSMR_ **

ASSEMBLY LENGTH*: 25 5/8"

OF COMPONENTS: 4



1 1/2" Floor Offset



R1.5OS_

AVAILABLE FINISHES: **10BE, A, AK, BSP, WSP**

R1.5OSMR_ **

ASSEMBLY LENGTH*: 28 3/4"

OF COMPONENTS: 5



1 3/4" Floor Offset



R1.75OS_

AVAILABLE FINISHES: **10BE, A, AK, BSP, WSP**

R1.75OSMR_ **

ASSEMBLY LENGTH*: 31 7/8"

OF COMPONENTS: 5



2" Floor Offset



R2OS_

AVAILABLE FINISHES: **10BE, A, AK, BSP, WSP**

R2OSMR_ **

ASSEMBLY LENGTH*: 35"

OF COMPONENTS: 6



Complete assembly drawings available online.

NOTE: Greater offset may be accomplished by using Pemko risers.

*Assembly length includes 7" top plate

**Miter Returns are not ADA Compliant



Assembly Shown: **R.5OS**



Experience a safer
and more open world

AVAILABLE FINISHES FOR PRODUCTS SHOWN ON THIS PAGE

10BE (Satin Bronze Powder Coated Aluminum) **A** (Mill Finish Aluminum) **AK** (Mill Finish Aluminum with PemKote™ Non-Slip Coating) **BSP** (Black Suede Powder Coated Aluminum) **WSP** (White Suede Powder Coated Aluminum)

800-824-3018 | www.pemko.com
Check the web site for the up-to-date catalog

Copyright © 2015-2024, ASSA ABLOY Accessories and Door Controls Group, Inc., an ASSA ABLOY Group company. All rights reserved. Reproduction in whole or in part without the express written permission of ASSA ABLOY Accessories and Door Controls Group, Inc. is prohibited.

SHORT OFFSET APPLICATIONS (3 1/2" TOP PLATE)

1/2" Floor Offset

R.5OSS_
R.5OSSMR_ **



AVAILABLE FINISHES: **10BE, A, AK, BSP, WSP**
ASSEMBLY LENGTH*: 12 3/4"
OF COMPONENTS: 3



3/4" Floor Offset

R.75OSS_
R.75OSSMR_ **



AVAILABLE FINISHES: **10BE, A, AK, BSP, WSP**
ASSEMBLY LENGTH*: 15 7/8"
OF COMPONENTS: 3



1" Floor Offset

R1OSS_
R1OSSMR_ **



AVAILABLE FINISHES: **10BE, A, AK, BSP, WSP**
ASSEMBLY LENGTH*: 19"
OF COMPONENTS: 4



1 1/4" Floor Offset

R1.25OSS_
R1.25OSSMR_ **



AVAILABLE FINISHES: **10BE, A, AK, BSP, WSP**
ASSEMBLY LENGTH*: 22 1/8"
OF COMPONENTS: 4



1 1/2" Floor Offset

R1.5OSS_
R1.5OSSMR_ **



AVAILABLE FINISHES: **10BE, A, AK, BSP, WSP**
ASSEMBLY LENGTH*: 25 1/4"
OF COMPONENTS: 5



1 3/4" Floor Offset

R1.75OSS_
R1.75OSSMR_ **



AVAILABLE FINISHES: **10BE, A, AK, BSP, WSP**
ASSEMBLY LENGTH*: 28 3/8"
OF COMPONENTS: 5



2" Floor Offset

R2OSS_
R2OSSMR_ **



AVAILABLE FINISHES: **10BE, A, AK, BSP, WSP**
ASSEMBLY LENGTH*: 31 1/2"
OF COMPONENTS: 6



Complete assembly drawings available online.

NOTE: Greater offset may be accomplished by using Pemko risers.

*Assembly length includes 3 1/2" top plate

**Miter Returns are not ADA Compliant



Assembly Shown: **R.75OSS**

AVAILABLE FINISHES FOR PRODUCTS SHOWN ON THIS PAGE

10BE (Satin Bronze Powder Coated Aluminum) **A** (Mill Finish Aluminum)
AK (Mill Finish Aluminum with PemKote™ Non-Slip Coating) **BSP** (Black Suede Powder Coated Aluminum)
WSP (White Suede Powder Coated Aluminum)

800-824-3018 | www.pemko.com

Check the web site for the up-to-date catalog

Copyright © 2015-2024, ASSA ABLOY Accessories and Door Controls Group, Inc., an ASSA ABLOY Group company. All rights reserved.
Reproduction in whole or in part without the express written permission of ASSA ABLOY Accessories and Door Controls Group, Inc. is prohibited.



Experience a safer
and more open world

MODULAR RAMP THRESHOLD COMPONENTS

- Components are generally sold as part of assemblies
 - Ramp Assemblies consist of interlocking components, eliminating the need to weld joints. Interlocking ball-joint design allows each component to flex and conform to uneven surfaces
 - All assemblies carry the following labels:   
 - PemKote™ is highly recommended for all threshold assemblies, especially exterior conditions where moisture may be present
- NOTE: The following pages are for component identification only. Do not order from these pages. Order only complete assemblies from pages 140 to 142

TOP PLATES

RAMP8_

Short top plate
AVAILABLE FINISHES: **10BE, A, AK, BSP, WSP**

RAMP1_

Top plate
AVAILABLE FINISHES: **10BE, A, AK, BSP, WSP**

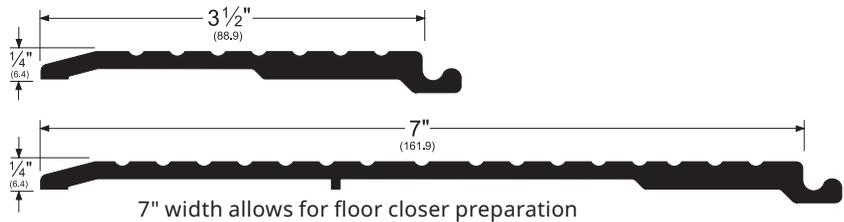

BRIDGES

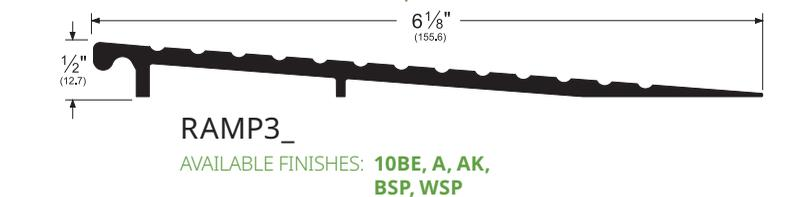
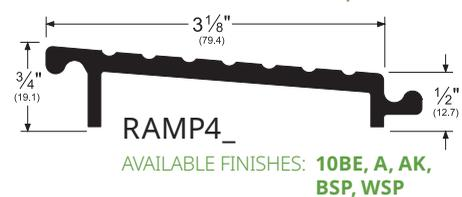
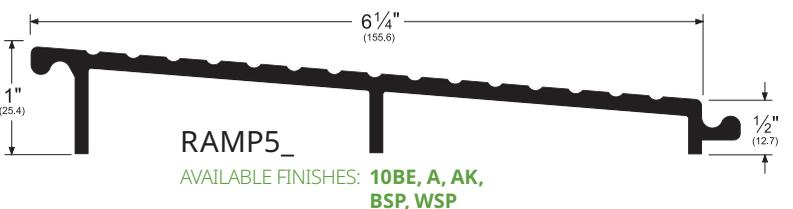
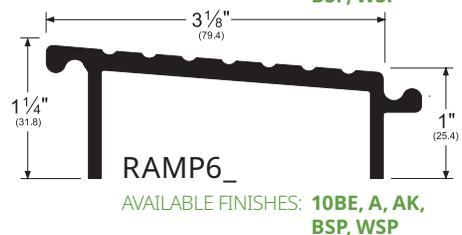
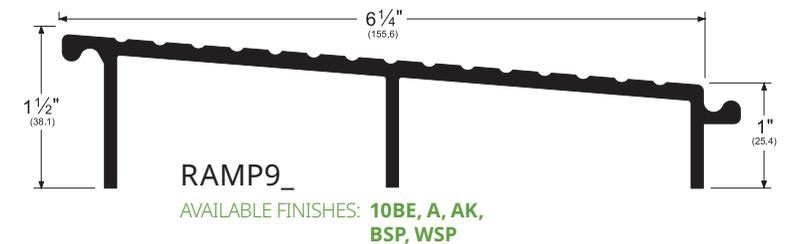
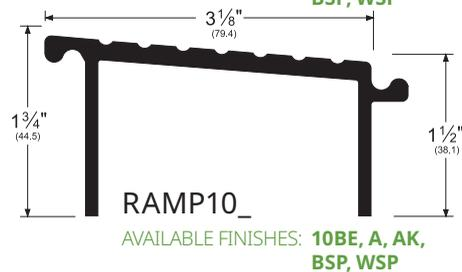
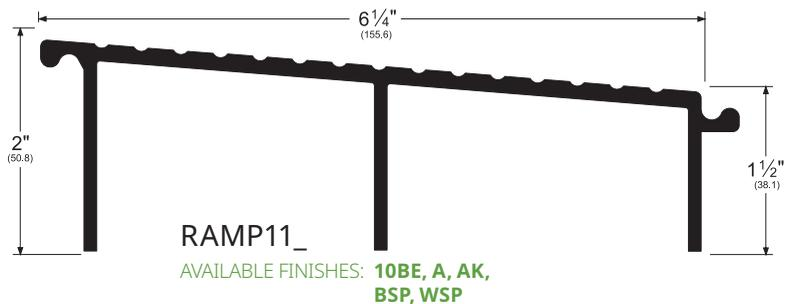
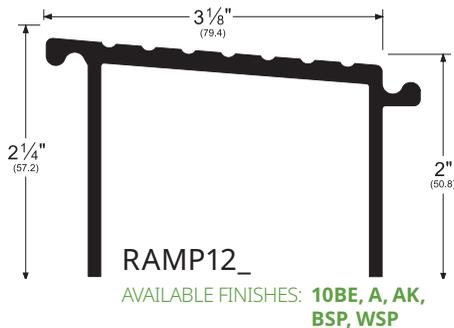

NOTE: Products shown in this section are not drawn to scale.

AVAILABLE FINISHES FOR PRODUCTS SHOWN ON THIS PAGE

10BE (Satin Bronze Powder Coated Aluminum) **A** (Mill Finish Aluminum) **AK** (Mill Finish Aluminum with PemKote™ Non-Slip Coating) **BSP** (Black Suede Powder Coated Aluminum) **WSP** (White Suede Powder Coated Aluminum)



Experience a safer and more open world

800-824-3018 | www.pemko.com
Check the web site for the up-to-date catalog

Copyright © 2015-2024, ASSA ABLOY Accessories and Door Controls Group, Inc., an ASSA ABLOY Group company. All rights reserved. Reproduction in whole or in part without the express written permission of ASSA ABLOY Accessories and Door Controls Group, Inc. is prohibited.

MODULAR RAMP THRESHOLD ASSEMBLIES - VARIABLES

- Use a "Variable" component to accommodate offsets from 1/2" to 1 1/4". These meet the 1:8 maximum slope allowance (ADA) for existing buildings. For new construction, this assembly is only ADA compliant in certain applications as outlined by the current ADA standard
- May require a variance from some state building codes, even though ADA compliant
- Ideal for use in cross traffic corridors where a minimal ramp projection may be required and a steeper slope may be allowed. Supplied with #10 stainless steel sheet metal screws. Stainless steel machine screws and expansion shields are available at an extra cost
- Miter returns are not available due to the variable angle of this ramp. Please fill and feather the threshold ends. Do not leave threshold ends open
- This variable ramp is supplied un-drilled from Pemko. Due to the variance in the angle, it must be drilled in the field. For proper installation, it requires the **RAMP7_** to be placed under **RAMP2_** after the assembly is in place, then must be match drilled and anchored through both components
- PemKote™ is highly recommended for all ramp threshold assemblies especially exterior conditions where moisture may be present
- In addition to ADA compliance, outlined previously, all assemblies carry the following labels: 

RVARIOSS_

AVAILABLE FINISHES: **10BE, A, AK, BSP, WSP**

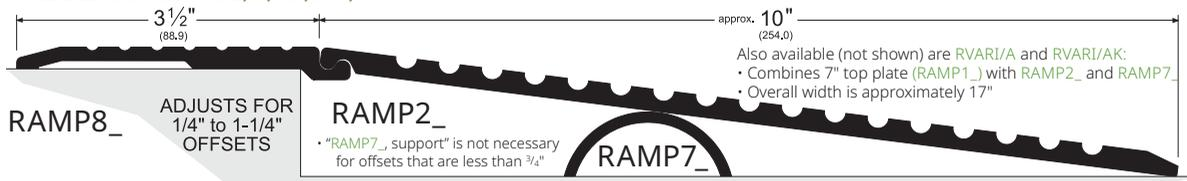

VARIABLE RAMP COMPONENTS

RAMP2_

variable

AVAILABLE FINISHES: **10BE, A, AK, BSP, WSP**

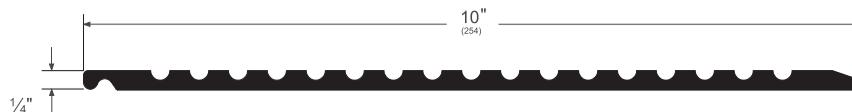

RAMP7_

support for variable

AVAILABLE FINISHES: **A**

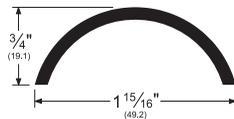

RISERS FOR MODULAR RAMPS

- Risers easily attach to the legs of Pemko's Modular Ramp Systems. Each adds 1/2" in height to accommodate offsets greater than 2 1/4"
- Contact Pemko Customer Service for information on stacking risers to reach desired height

RAMP13_

AVAILABLE FINISHES: **A**

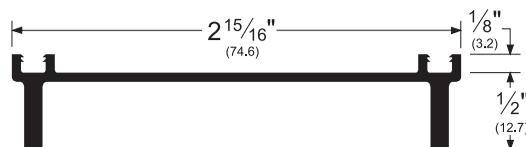

RAMP14_

AVAILABLE FINISHES: **A**

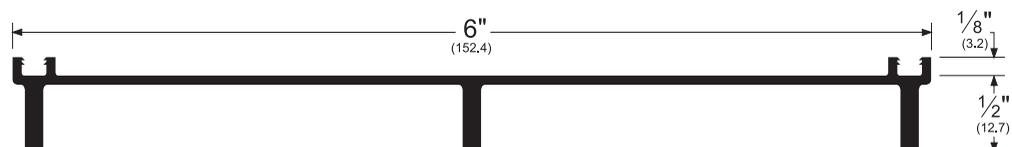

NOTE: Products shown in this section are not drawn to scale.

AVAILABLE FINISHES FOR PRODUCTS SHOWN ON THIS PAGE

10BE (Satin Bronze Powder Coated Aluminum) **A** (Mill Finish Aluminum) **AK** (Mill Finish Aluminum with PemKote™ Non-Slip Coating) **BSP** (Black Suede Powder Coated Aluminum) **WSP** (White Suede Powder Coated Aluminum)

800-824-3018 | www.pemko.com

Check the web site for the up-to-date catalog

Copyright © 2015-2024, ASSA ABLOY Accessories and Door Controls Group, Inc., an ASSA ABLOY Group company. All rights reserved. Reproduction in whole or in part without the express written permission of ASSA ABLOY Accessories and Door Controls Group, Inc. is prohibited.

PEMKO
ASSA ABLOY

Experience a safer
and more open world

MITER RETURNS FOR ALL MODULAR RAMP THRESHOLDS

- Cast aluminum “wings” fit into end of modular ramp threshold assembly and are fastened to ramp mid sections with self-tapping machine screws
- Neat, compact, and tight-fitting design replaces former mitering methods

- Miter Returns are match-drilled with each assembly
- Miter Returns are not “ADA” compliant
- Miter Returns are handed from the low end and are determined by which side of the ramp it fits into



WING10_H_

AVAILABLE FINISHES: **A, AK**

- WING10 can be trimmed to fit ramp assembly (dotted lines show cut down for use with R.5FMR_)

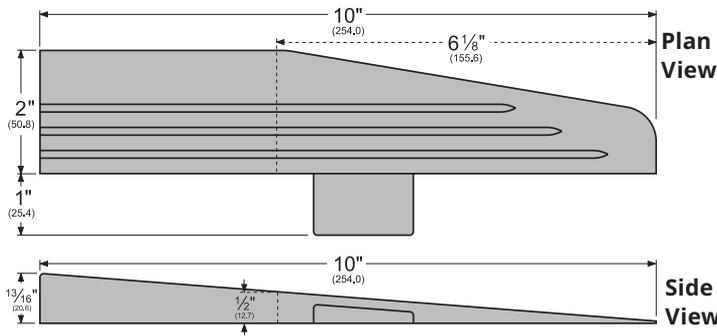

WING10RH_

(right-hand shown)

End View

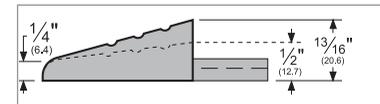

View from high-end

WING16_H_

AVAILABLE FINISHES: **A, AK**

- WING16 can be trimmed to fit ramp assembly (dotted lines show cut down for use with R1FMR_)

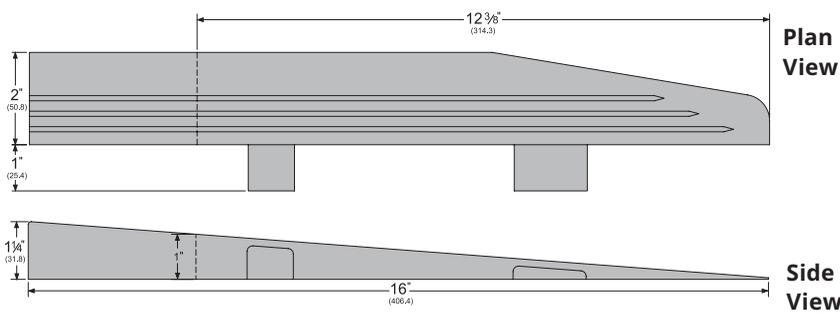

WING16RH_

(right-hand shown)

End View

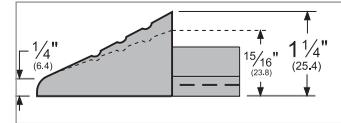

View from high-end

WINGEXT_H_

AVAILABLE FINISHES: **A, AK**

- WINGEXT are included with assemblies to completely fill ends for 2" offset or 2 1/4" flush conditions
WINGEXT works in conjunction with WING16 for these higher offset conditions

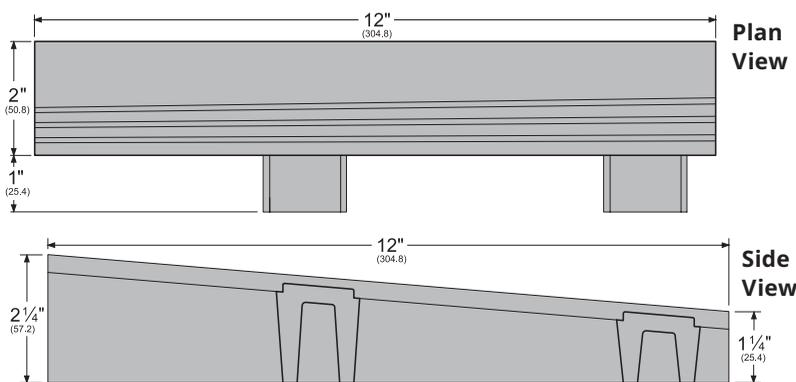

WINGEXTRH_

(right-hand shown)

End View

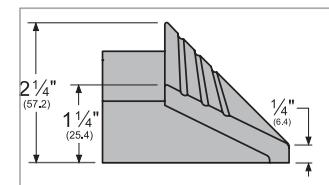

View from high-end

See flyer on the Literature page of www.assaabloydooraccessories.us for WING cut-down chart.



Experience a safer and more open world

AVAILABLE FINISHES FOR PRODUCTS SHOWN ON THIS PAGE
A (Mill Finish Aluminum) **AK** (Mill Finish Aluminum with PemKote™ Non-Slip Coating)

800-824-3018 | www.pemko.com
Check the web site for the up-to-date catalog

Copyright © 2015-2024, ASSA ABLOY Accessories and Door Controls Group, Inc., an ASSA ABLOY Group company. All rights reserved. Reproduction in whole or in part without the express written permission of ASSA ABLOY Accessories and Door Controls Group, Inc. is prohibited.

BARRIER-FREE RAMP THRESHOLDS

- The modular ramp thresholds are an improvement over the **257/259** however, **257/259** will remain available for special requirements
- Use **257_** and **259_** together, or use **257_** with an abutted 1:12 concrete slope
- When used as a cover plate assembly (see Commercial Thresholds section), a longer spindle may be required
- Ramps on this page are not ADA compliant when used at a door opening
- The **257_** is not ADA compliant when used alone.
- PemKote™ is highly recommended for all threshold assemblies, especially exterior conditions where moisture may be present

257x259_

AVAILABLE FINISHES: **10BE, A, AK, BSP, WSP**

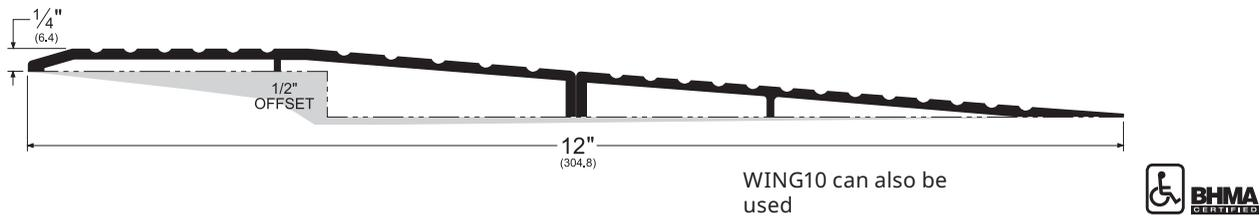

259_

AVAILABLE FINISHES: **10BE, A, AK, BSP, WSP**

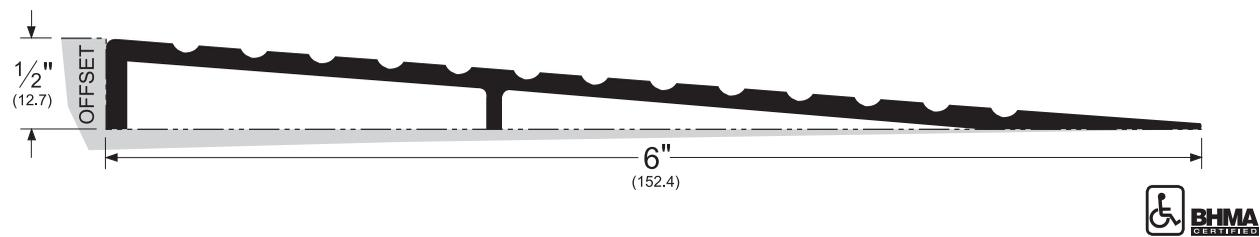

257_

AVAILABLE FINISHES: **10BE, A, AK, BSP, WSP**

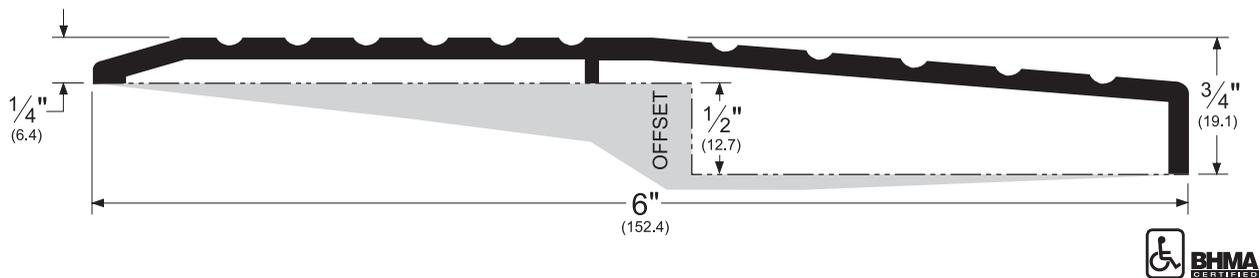

NOTE: Products shown in this section are not drawn to scale.

AVAILABLE FINISHES FOR PRODUCTS SHOWN ON THIS PAGE
10BE (Satin Bronze Powder Coated Aluminum) **A** (Mill Finish Aluminum)
AK (Mill Finish Aluminum with PemKote™ Non-Slip Coating) **BSP** (Black Suede Powder Coated Aluminum)
WSP (White Suede Powder Coated Aluminum)

800-824-3018 | www.pemko.com
 Check the web site for the up-to-date catalog

Copyright © 2015-2024, ASSA ABLOY Accessories and Door Controls Group, Inc., an ASSA ABLOY Group company. All rights reserved.
 Reproduction in whole or in part without the express written permission of ASSA ABLOY Accessories and Door Controls Group, Inc. is prohibited.

PEMKO
ASSA ABLOY

Experience a safer
 and more open world

FIRE RETARDANT AND STYRENE BUTADIENE RUBBER RAMP THRESHOLDS

- Rubber ramps meet the requirements of **ADAAG-2010; IBC/ANSI A117.1; and California Title 24, Part 2**
- Styrene butadiene rubber ramps are weather, ozone, abrasion, and impact resistant; long-lasting and fire retardant
- Rubber ramps are sold in one foot increments up to 15-foot lengths
- Rubber ramps can be butted together for longer lengths
- Rubber ramps are cut square on each end but are available with molded rubber miter returns. To receive a pair of miter returns, add "MR" to the part number (example: **SBR.5FMR**)
- Rubber ramps have a superior grip, anti-slip surface and a "no bump" tapered lead edge. Rubber ramps are classified by Underwriters Laboratories, Inc.,[®] as a skid-resistant floor surface per **UL standard for safety, UL410**. Rubber ramps also meet the requirements of **ASTM D 2047** and **Federal Specification P-F-430C**
- Rubber ramps are easy to install on most surfaces by using a construction adhesive. Mechanical fasteners are not required and not recommended
- Rubber ramps are also portable. For temporary applications, an assembly stays in place by its sheer weight and can be removed from one opening and placed at another opening
- Use an adhesive (caulk) suitable for use with plastics and your flooring material for proper installation and adhesion
- Rubber ramps are available for 1/2" and 1" offset heights
- Rubber ramps can be cross-cut to length or ripped to a custom offset height using a table or radial arm saw with a carbide-tipped blade. These modifications must be made in the field

SBR1F
SBR1FMR **

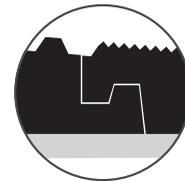
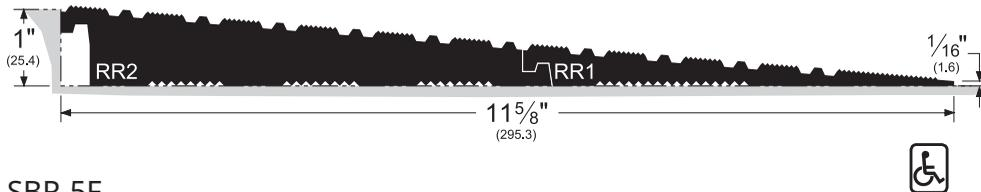

Assembly consists of two inter-locking components.

SBR.5F
SBR.5FMR **
RR1

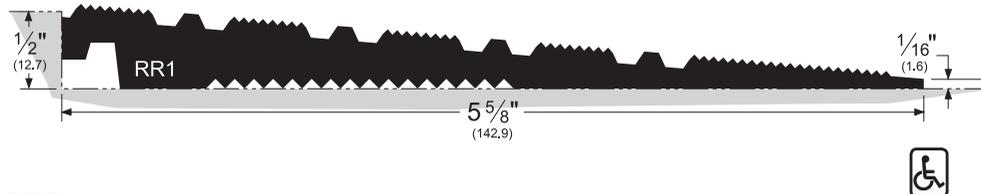

RR2

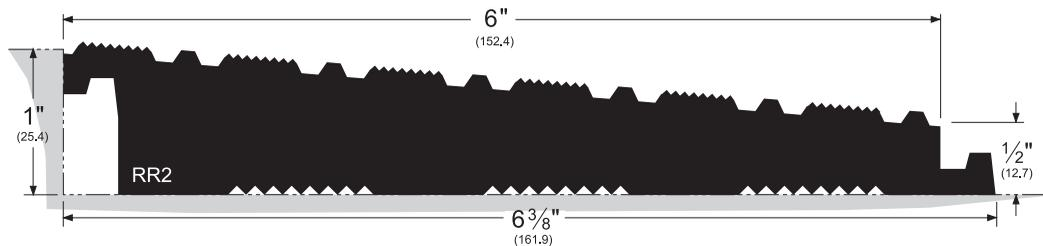

This component (**RR2**) is not ADA compliant when used by itself.

NOTE: Products shown in this section are not drawn to scale.

** = Miter Returns are not ADA compliant



Experience a safer and more open world

800-824-3018 | www.pemko.com
Check the web site for the up-to-date catalog

Copyright © 2015-2024, ASSA ABLOY Accessories and Door Controls Group, Inc., an ASSA ABLOY Group company. All rights reserved. Reproduction in whole or in part without the express written permission of ASSA ABLOY Accessories and Door Controls Group, Inc. is prohibited.

RECYCLED RUBBER RAMP ASSEMBLY

- ADA Compliant, based on application
- Meets: **UL410, ASTM D2047, Federal Specification P-F-430C**
- Recycled Rubber Ramp Assemblies meet **IBC/ANSI A117.1-2013**
- Made from #20 mesh minus crumb rubber (with urethane binders) reclaimed from 100% recycled rubber automotive tires
- Use an adhesive (caulk) suitable for use with plastics and your flooring material for proper installation and adhesion. Avoid Liquid Nails with Rubber Ramps
- Using ordinary tools, trim to fit your application
- Can be ripped for offsets less than 1 1/4"
- Plane bottom surface of ramp to accommodate irregular surface conditions
- Miter returns are molded into the design of the Recycled Rubber Ramp
- 36" and 60" ramps are supplied as one (1) piece assemblies
- 48" and 72" ramps are supplied as two (2) piece assemblies
- Dimensions are nominal and can vary by as much as one inch. This is acceptable as long as the two halves match

Ordering Chart

Other sizes are available, please contact Pemko Customer Service.

PART #	WIDTH "A" (door opening)	WIDTH "B" (total width)
RR1.25FMR36	36"	41"
RR1.25FMR48	48"	53"
RR1.25FMR60	60"	65"
RR1.25FMR72	72"	77"
RR1.25FMR96	96"	101"

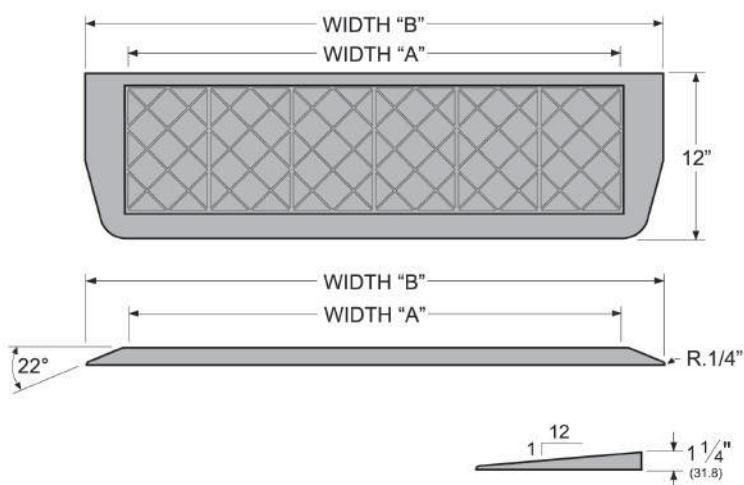



Experience a safer
and more open world

800-824-3018 | www.pemko.com
Check the web site for the up-to-date catalog

Copyright © 2015-2024, ASSA ABLOY Accessories and Door Controls Group, Inc., an ASSA ABLOY Group company. All rights reserved.
Reproduction in whole or in part without the express written permission of ASSA ABLOY Accessories and Door Controls Group, Inc. is prohibited.

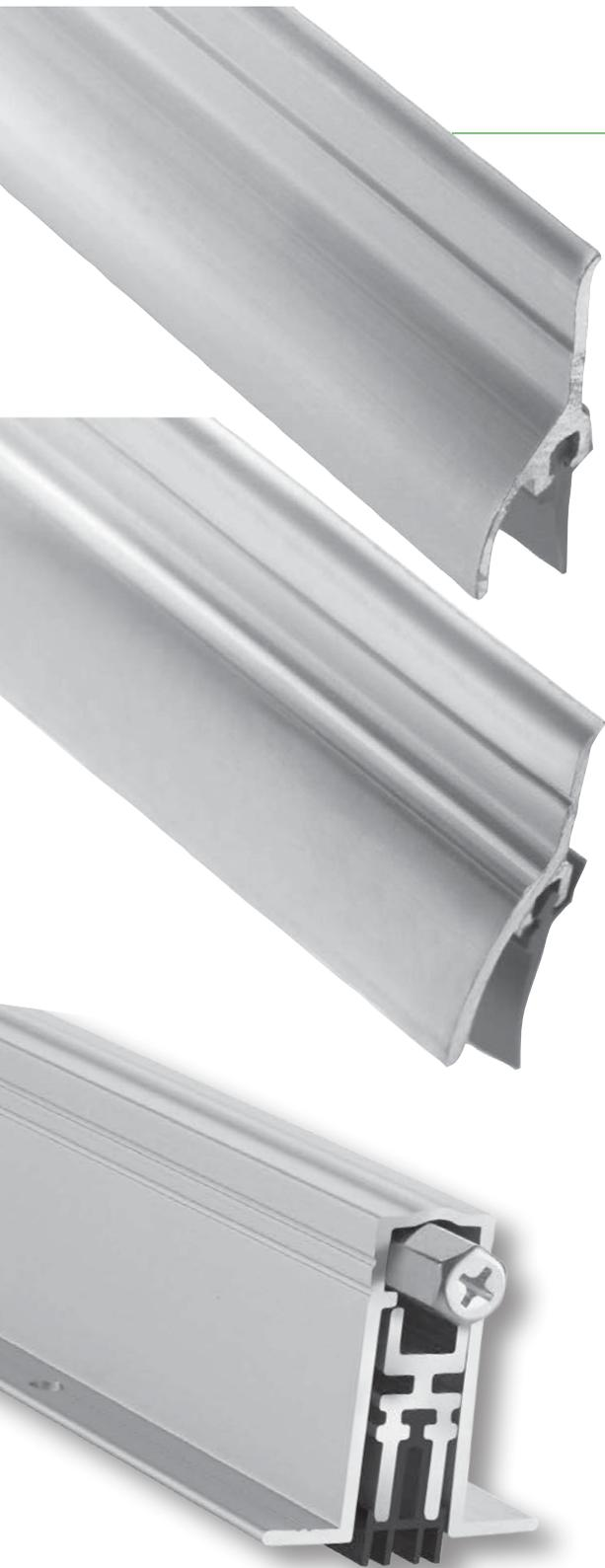

PEMKO DOOR BOTTOMS

CONTENTS:

- Automatic Door Bottoms 132
- Residential Automatic Door Bottoms 136
- End Plates for Automatic Door Bottoms 137
- Excessive Gap Door Bottom Solutions 138
- Excessive Gap Door Top Solutions 138
- Eco-V™ Door Shoes 138
- Door Shoes 139
- Thermally Broken Door Shoe 141
- Door Sweeps for Hollow Metal Doors 142
- Fabrication Options for Door Shoes 142
- Door Bottom Sweeps 143
- Stainless Steel Door Bottom Sweeps 146
- Specialty Door Bottoms 147
- Door Top Weatherstrip 147
- Heavy Duty Door Bumper 147

INDEX:

PRODUCT	PAGE	PRODUCT	PAGE	PRODUCT	PAGE
56	144	344	147	18061	145
57	144	345	144	18100	145
68	147	345	145	18137	145
196	147	346	147	90062	145
209	139	347	147	90100	145
210	139	368	143	293100	145
211	139	405	136	E199	147
215	139	411	135	EGA305xG	138
216	139	412	134	EV80	138
216_FG	141	420	135	K411	137
217	139	434	135	K412	137
221	141	2113	140	K420	137
222	142	2170	138	K435	137
223	140	2173	140	K435-PREM	137
234	139	2211	141	K436	137
307	144	2212	141	K436SM	137
308	144	2221	142	K4133	137
313	147	2343	140	K4301	137
314	147	3151	143	SA1	136
315	143	3151SS	146	SA2	136
315SS	146	3452	144	SA3	136
317	147	3452	145	SA4	136
321	143	3692	140	STC411	133
321SS	146	4131	134	STC4131	133
325XGSS	138	4301	134	XG2212	138

800-824-3018 | www.pemko.com
 Check the web site for the up-to-date catalog

Copyright © 2015-2024, ASSA ABLOY Accessories and Door Controls Group, Inc., an ASSA ABLOY Group company. All rights reserved.
 Reproduction in whole or in part without the express written permission of ASSA ABLOY Accessories and Door Controls Group, Inc. is prohibited.



Experience a safer
and more open world

AUTOMATIC DOOR BOTTOMS

- All Pemko Automatic Door Bottoms, 24" and up, can be manufactured for field alteration. Please specify when ordering: Allow 2" for field trimming
- Overall sizes range from 12" to 72". Sizes between 12" and 23.9" will be supplied at absolute NET length and will have no room for field trimming.
- 0.0625" Lead-lining available upon request; contact Pemko Customer Service for options on profiles
- Provided with end plate kits (except 420, SA, and 405V models) which include wood screws. Tek screws are available for mounting to hollow metal doors.
- See Planet Automatic Door Bottoms for additional models made by ASSA ABLOY Schweisse and offered in the U.S.A. by Pemko.

IMPORTANT DROP BAR INFORMATION

Drop seals of all types are designed to close a uniform size gap. Pemko drop seals can seal up to $\frac{3}{4}$ " gaps (420 model can seal up to $\frac{1}{2}$ " gap), provided the gap is consistent. Gaps that start at less than $\frac{3}{4}$ " and then grow cannot be closed. The drop seal utilizes a straight aluminum extrusion so it cannot close an inconsistent gap. Plunger extension to drop dimension is 1:1 (i.e., a $\frac{1}{4}$ " extension on the plunger will equal a $\frac{1}{4}$ " drop of the drop bar).

DROP-BAR SEAL ACTUATION

The drop bar mechanism prevents the seal from skidding along the floor/threshold while the door is being closed.



PEMKO
ASSA ABLOY

Experience a safer
and more open world

800-824-3018 | www.pemko.com
Check the web site for the up-to-date catalog

Copyright © 2015-2024, ASSA ABLOY Accessories and Door Controls Group, Inc., an ASSA ABLOY Group company. All rights reserved. Reproduction in whole or in part without the express written permission of ASSA ABLOY Accessories and Door Controls Group, Inc. is prohibited.

AUTOMATIC DOOR BOTTOMS - ACOUSTIC

- Non-handed
- Recommended gap under door is $\frac{3}{8}$ " for optimal acoustic performance; max drop is $\frac{3}{4}$ "
- Internal mechanism allows bar to accommodate slight imperfections in floor materials
- STC411 end plate kit is K435; for doors narrower than $1-\frac{3}{4}$ ", specify end plate kit K411
- STC4131 end plate kit is K4133C for Clear Anodized and K4133D for Dark Bronze Anodized

STC411_PK

AVAILABLE FINISHES: **A**
 REPLACEMENT INSERT:
PK4111 (BL)
 ANSI: **R3G324, R3G325**

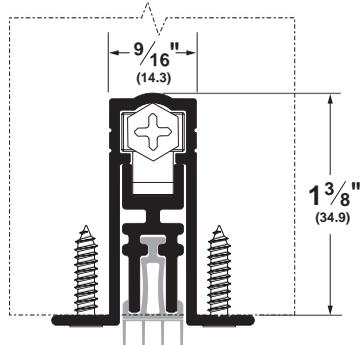

STC4131_PK

AVAILABLE FINISHES:
10BE, BSP, C, D, WSP
 REPLACEMENT INSERT: **PK4111 (BL)**
 ANSI: **R3G334, R3G335, R3G344,**
R3G345

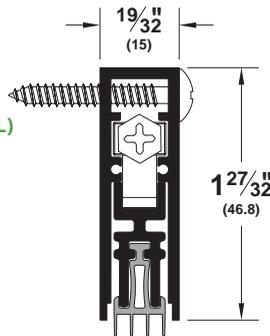

NOTE: STC411_PK Automatic Door Bottom is now included in PEMKOSTCSET-1 (A through E).
 Please see Acoustic Products section for more information.

NOTE: Products shown in this section may not be drawn to scale.

AVAILABLE FINISHES FOR PRODUCTS SHOWN ON THIS PAGE

10BE (Satin Bronze Powder Coated Aluminum) **A** (Mill Finish Aluminum) **BSP** (Black Suede Powder Coated Aluminum)
C (Clear Anodized) **D** (Dark Bronze Anodized) **WSP** (White Suede Powder Coated Aluminum)

800-824-3018 | www.pemko.com

Check the web site for the up-to-date catalog

Copyright © 2015-2024, ASSA ABLOY Accessories and Door Controls Group, Inc., an ASSA ABLOY Group company. All rights reserved.
 Reproduction in whole or in part without the express written permission of ASSA ABLOY Accessories and Door Controls Group, Inc. is prohibited.

PEMKO
ASSA ABLOY

Experience a safer
 and more open world

AUTOMATIC DOOR BOTTOMS - SURFACE AND SEMI-MORTISE MODELS

- Specify if the Automatic Door Bottom is for a semi-mortise application so that shorter screws can be provided
- Recommended gap under door is 1/2"; maximum drop is 3/4"
- 4301 end plate kit is K436 for surface mounted applications and K436SM for semi-mortised applications
- 4131 end plate kit is K4133
- 412 end plate kit is K412R1

4301_NBL

AVAILABLE FINISHES:
BSP, C, D
 REPLACEMENT INSERT:
P516062 (BL, GR, W)
 ANSI: **R3A334, R3A335, R3A344, R3A345**

nylon brush (NB)

4301_PKL

AVAILABLE FINISHES:
BSP, C, D
 REPLACEMENT INSERT:
PK4304 (BL)
 ANSI: **R3G334, R3G335, R3G344, R3G345**

PemkoPrene™ (PK)

Alternate Insert For 4301

4301_RL

AVAILABLE FINISHES:
BSP, C, D
 REPLACEMENT INSERT:
E4303 (BL)
 ANSI: **R3G334, R3G335, R3G344, R3G345**

sponge EPDM (R)

4131_NBL

AVAILABLE FINISHES:
BSP, C, D, SN
 REPLACEMENT INSERT:
P516041 (BL, GR)
 ANSI: **R3A334, R3A335, R3A344, R3A345**

nylon brush (NB)

4131_RL

AVAILABLE FINISHES:
BSP, C, D, SN
 REPLACEMENT INSERT:
E7 (BL)
 ANSI: **R3G334, R3G335, R3G344, R3G345**

sponge EPDM (R)

Alternate Inserts For 4131

4131_PKL

AVAILABLE FINISHES:
BSP, C, D, SN
 REPLACEMENT INSERT:
PK4132 (BL)
 ANSI: **R3G334, R3G335, R3G344, R3G345**

PemkoPrene™ (PK)

4131_SL

AVAILABLE FINISHES:
BSP, C, D, SN
 REPLACEMENT INSERT:
SR6 (BL)
 ANSI: **R3E334, R3E335, R3E344, R3E345**

sponge silicone (S)

412_NBL

AVAILABLE FINISHES:
B, BSP, C, D, S
 REPLACEMENT INSERT:
P516041 (BL, GR)
 ANSI: **R3A334, R3A335**

- Surface mounted application
- Handed and disassembly of the mechanism is required to reverse the hand

nylon brush (NB)

412_RL

AVAILABLE FINISHES:
B, BSP, C, D, S
 REPLACEMENT INSERT:
E7 (BL)
 ANSI: **R3G334, R3G335**

- Surface mounted application
- Handed and disassembly of the mechanism is required to reverse the hand

sponge EPDM (R)

Alternate Inserts For 412

412_SL

AVAILABLE FINISHES:
B, BSP, C, D, S
 REPLACEMENT INSERT:
SR6 (BL)
 ANSI: **R3E334, R3E335**

sponge silicone (S)

412_PKL

AVAILABLE FINISHES:
B, BSP, C, D, S
 REPLACEMENT INSERT:
PK4132 (BL)
 ANSI: **R3G334, R3G335**

PemkoPrene™ (PK)

All above products

NOTE: Products shown in this section may not be drawn to scale.

AVAILABLE FINISHES FOR PRODUCTS SHOWN ON THIS PAGE

B (Cladded Brass Shell) **BSP** (Black Suede Powder Coated Aluminum) **C** (Clear Anodized) **D** (Dark Bronze Anodized) **S** (Cladded Stainless Steel) **SN** (Satin Nickel Anodized)

800-824-3018 | www.pemko.com

Check the web site for the up-to-date catalog

PEMKO
ASSA ABLOY

Experience a safer
 and more open world

AUTOMATIC DOOR BOTTOMS - FULL-MORTISE MODELS

- Recommended drop is 1/2"; maximum drop is 3/4", except where noted
- 411 and 434 end plate kit is K435. When using 411 model on doors narrower than 1 3/4", specify end plate kit K411
- 420 is used on hollow metal doors and does not come with end plates; requires a hole for the plunger to extend through in the hinge side door edge.

434_NBL

AVAILABLE FINISH: **A**
 REPLACEMENT INSERT: **P516062 (BL, GR, W)**
 ANSI: **R3A324, R3A325**

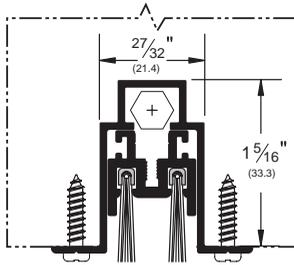

nylon brush (NB)



434_RL

AVAILABLE FINISH: **A**
 REPLACEMENT INSERT: **E4303 (BL)**
 ANSI: **R3G324, R3G325**

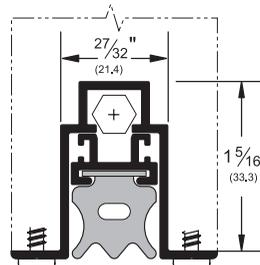

sponge EPDM (R)



411_NBL

AVAILABLE FINISH: **A**
 REPLACEMENT INSERT: **P516041 (BL, GR)**
 ANSI: **R3A324, R3A325**

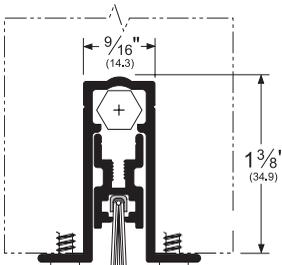

nylon brush (NB)



411_RL

AVAILABLE FINISH: **A**
 REPLACEMENT INSERT: **E7 (BL)**
 ANSI: **R3G324, R3G325**

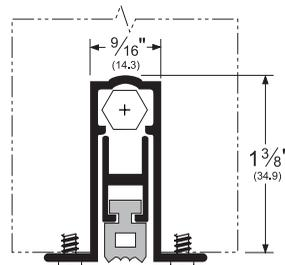

sponge EPDM (R)



420_PKL

AVAILABLE FINISH: **A**
 REPLACEMENT INSERT: **S4 (BL, GR)**
 ANSI: **R3G324, R3G325**

- For hollow metal doors maximum drop is 1/2"
- Recommended drop is 3/8"

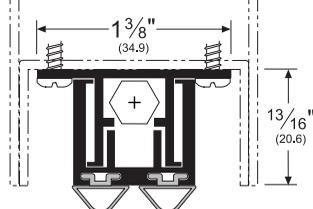

PemkoPrene™ (PK)



Alternate Inserts For 434

434_PKL

AVAILABLE FINISH: **A**
 REPLACEMENT INSERT: **PK4304 (BL)**
 ANSI: **R3G324, R3G325**



Alternate Inserts For 411

411_PKL

AVAILABLE FINISH: **A**
 REPLACEMENT INSERT: **PK4132 (BL)**
 ANSI: **R3G324, R3G325**



411_SL

AVAILABLE FINISHES: **A**
 REPLACEMENT INSERT: **SR6 (BL)**
 ANSI: **R3E324, R3E325**



Alternate Inserts For 420

420_VL

AVAILABLE FINISH: **A**
 REPLACEMENT INSERT: **EV41 (BL, GR, W)**

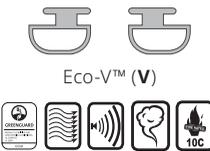

420_SL

AVAILABLE FINISH: **A**
 REPLACEMENT INSERT: **S4 (BL, GR)**
 ANSI: **R3G324, R3G325**



NOTE: Products shown in this section may not be drawn to scale.

AVAILABLE FINISHES FOR PRODUCTS SHOWN ON THIS PAGE
A (Mill Finish Aluminum)

800-824-3018 | www.pemko.com

Check the web site for the up-to-date catalog

Copyright © 2015-2024, ASSA ABLOY Accessories and Door Controls Group, Inc., an ASSA ABLOY Group company. All rights reserved.
 Reproduction in whole or in part without the express written permission of ASSA ABLOY Accessories and Door Controls Group, Inc. is prohibited.



Experience a safer
 and more open world

RESIDENTIAL AUTOMATIC DOOR BOTTOMS

SA1_, SA2_, SA3_, SA4_

AVAILABLE FINISHES: **A** (no finish selection), **D**
 AVAILABLE LENGTHS: **28", 32", 36", 42"**
 REPLACEMENT INSERT: **EV5 (BL)**

- Surface type for wood doors
- 1/2" maximum drop
- Can be trimmed down by as much as 2"
- Non-handed
- End plates are not provided

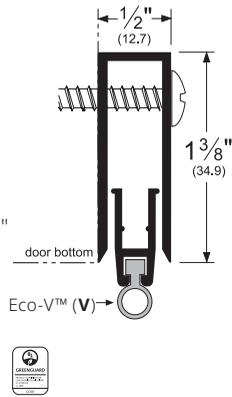

405_V

AVAILABLE FINISHES: **C, D, PW**
 REPLACEMENT INSERT: **EV43 (BL, GR)**

- Spring loaded door bottom sweep
- Available in 36" length only
- May be cut down to 24" minimum length

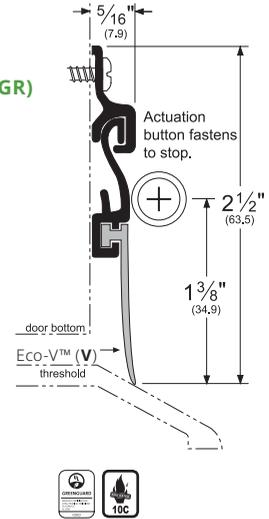
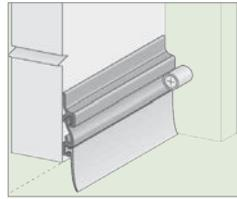

NOTE: Products shown in this section may not be drawn to scale.

AVAILABLE FINISHES FOR PRODUCTS SHOWN ON THIS PAGE
A (Mill Finish Aluminum) **C** (Clear Anodized)
D (Dark Bronze Anodized) **PW** (Painted White)



Experience a safer
and more open world

END PLATES FOR AUTOMATIC DOOR BOTTOMS

- Metal end plates are provided to protect the mechanism and to give a clean, aesthetic appearance. Do not tighten with power tool
- Plunger end plate prevents the plunger adjustment from rotating
- Necessary fasteners are provided with End Plate kits; color corresponds with case color
- All end plates are black in color

411 and STC411®
End Plates Mortise

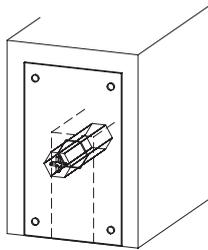
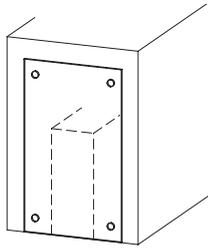

434 End Plates
Mortise

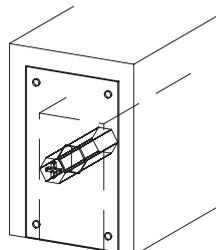
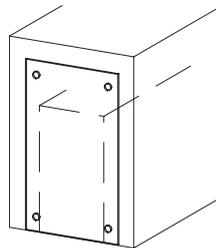

4131 and STC4131®
Auto Door Bottom
Semi-Mortise*

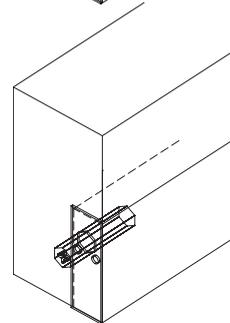
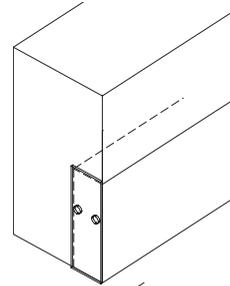

4301 Auto
Door Bottom
Semi-Mortise*

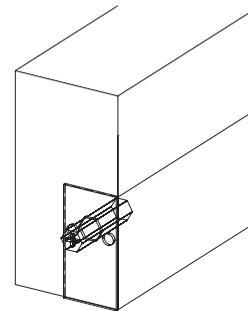
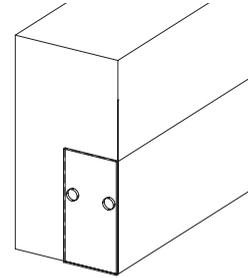

412 New Style
End Plates

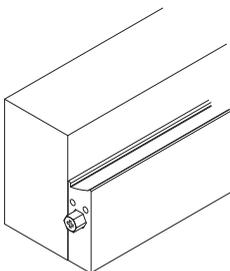
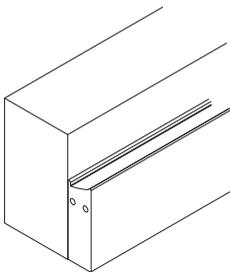

Automatic Door Bottom Kits

K411	Optional Kit for 411 and STC411 Door Bottom, 1 ³ / ₈ " Doors
K412R1C	Kit for new style 412 Door Bottom - Clear
K412R1D	Kit for new style 412 Door Bottom - Dark Bronze
K4133C	Kit for 4131, STC4131 Door Bottoms, Clear
K4133D	Kit for 4131, STC4131 Door Bottoms, Dark Bronze
K4133G	Kit for 4131 Door Bottom, Bright Dip Gold
K420	Kit for 420 Door Bottom
K435	Standard Kit for 411, 434, and STC411 Door Bottom
K436	Kit for 4301 Door Bottom (surface)
K436SM	Kit for 4301 Door Bottom (semi-mortised)
K435-PREM	Special End-Support Mounting Kit for 434 (sold separately)

800-824-3018 | www.pemko.com

Check the web site for the up-to-date catalog

Copyright © 2015-2024, ASSA ABLOY Accessories and Door Controls Group, Inc., an ASSA ABLOY Group company. All rights reserved.
Reproduction in whole or in part without the express written permission of ASSA ABLOY Accessories and Door Controls Group, Inc. is prohibited.

PEMKO
ASSA ABLOY

Experience a safer
and more open world

EXCESSIVE GAP DOOR BOTTOM SOLUTIONS

- Brings fire-rated doors with excessive bottom gaps back into spec - up to 1-1/2"
- UL Classified for 90-minutes
- Supplied net length (as ordered)
- Patent Pending

XG2212_PK773

AVAILABLE FINISHES: **A, BSP, WSP, 10BE**
REPLACEMENT INSERT: **PK773 (BL)**

- Aluminum construction
- Easily field modifiable with standard equipment
- Supplied with K450XG end plate kit
- Patent Pending

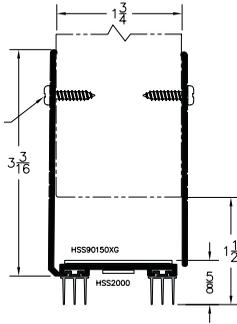

325XGSSN

AVAILABLE FINISHES: **SS, SSBSP, SSWSP, SS10BE**
REPLACEMENT INSERT: **N25 (BL)**

- Stainless steel door sweep paired with stainless steel angle
- #4 brushed stainless steel
- Supplied with K450XG end plate kit

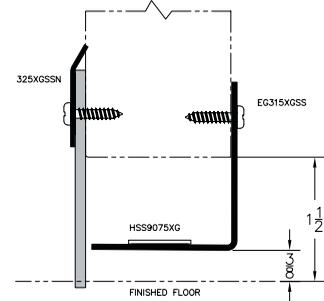

EXCESSIVE GAP DOOR TOP SOLUTIONS

- Brings fire-rated doors with excessive top gaps back into spec - up to 1/2"
- UL Classified for 90-minutes
- Supplied net length (as ordered)

EGA305XG_

AVAILABLE FINISHES: **SS, SSBSP, SSWSP, SS10BE**

- Stainless steel construction, #4 brushed
- Supplied with HSS2000 intumescent
- Supplied with K450XG end plate kit

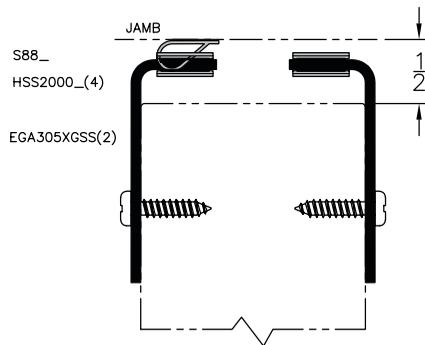

ECO-V™ DOOR SHOES

- Dual durometer Eco-V™ door shoe
- EV80_ is furnished net 36"
- Supplied Net Length (as ordered)

EV80_

AVAILABLE FINISHES: **D**
AVAILABLE LENGTHS: **36" NET**

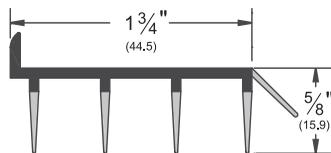

2170_V

AVAILABLE COLORS: **D, W**
AVAILABLE LENGTHS: **36", 48"**

Also available with unnotched insert:
2170_V36UN
2170_V48UN

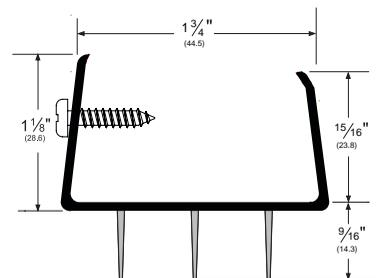

NOTE: Products shown in this section may not be drawn to scale.

AVAILABLE FINISHES FOR PRODUCTS SHOWN ON THIS PAGE
10BE (Satin Bronze Powder) **A** (Mill Finish Aluminum) **BSP** (Black Suede Powder)
SS (Stainless Steel) **WSP** (White Suede Powder)
Eco-V® DOORS SHOES: **D** (Dark Brown) **W** (White)

PEMKO
ASSA ABLOY

Experience a safer
and more open world

800-824-3018 | www.pemko.com
Check the web site for the up-to-date catalog

DOOR SHOES

- Profiles on this page available with PemkoPrene™ (PK) or Eco-V™ (V); both are the same shape and size
- Slotted holes for easy adjustment
- Rain drip model is ideal for deflecting rain away from the bottom of door
- Recommended compression of gasket fins is 1/16"
- Except where specified otherwise, supplied with 1/4" undercut from length ordered. Specify "NET LENGTH" to receive length as ordered.

216_V

AVAILABLE FINISHES: **A, B, BDG, BSP, D, SN, WSP**
 REPLACEMENT INSERT: **EV9 (BL, GR)**
 ANSI: **R3D514**

216_PK

AVAILABLE FINISHES: **A, B, BDG, BSP, D, SN, WSP**
 REPLACEMENT INSERT: **PK9 (BL, GR)**
 ANSI: **R3G514**

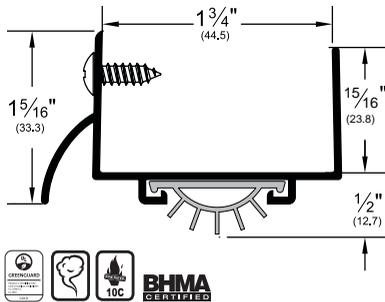

215_V

AVAILABLE FINISHES: **A, BDG, BSP, D, PW, SN**
 REPLACEMENT INSERT: **EV9 (BL, GR)**
 ANSI: **R3D514**

215_PK

AVAILABLE FINISHES: **A, BDG, BSP, D, PW, SN**
 REPLACEMENT INSERT: **PK9 (BL, GR)**
 ANSI: **R3G514**

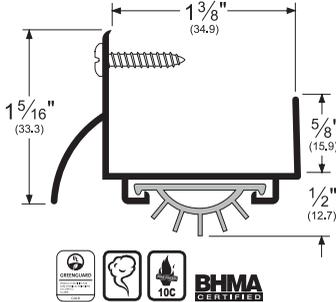

210_V

AVAILABLE FINISHES: **A, BSP, D, PW, SN**
 REPLACEMENT INSERT: **EV9 (BL, GR)**
 ANSI: **R3D514**

210_PK

AVAILABLE FINISHES: **A, BSP, D, PW, SN**
 REPLACEMENT INSERT: **PK9 (BL, GR)**
 ANSI: **R3G514**

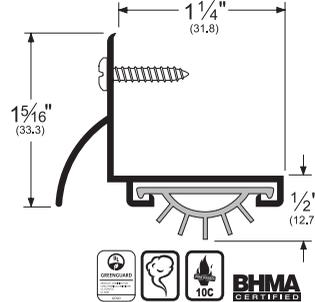

217_V

AVAILABLE FINISHES: **A, BSP, D, G, SN, WSP**
 REPLACEMENT INSERT: **EV9 (BL, GR)**
 ANSI: **R3D414**

217_PK

AVAILABLE FINISHES: **A, BSP, D, G, SN, WSP**
 REPLACEMENT INSERT: **PK9 (BL, GR)**
 ANSI: **R3G414**

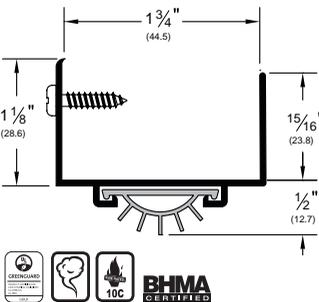

211_V

AVAILABLE FINISHES: **A, BSP, D, G, WSP**
 REPLACEMENT INSERT: **EV9 (BL, GR)**
 ANSI: **R3D414**

211_PK

AVAILABLE FINISHES: **A, BSP, D, G, WSP**
 REPLACEMENT INSERT: **PK9 (BL, GR)**
 ANSI: **R3G414**

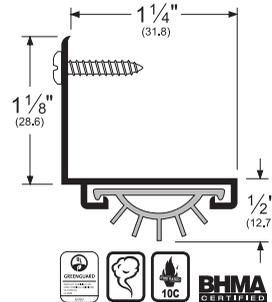

234_V

AVAILABLE FINISHES: **A, BSP, D, G**
 REPLACEMENT INSERT: **EV9 (BL, GR)**
 ANSI: **R3D414**

234_PK

AVAILABLE FINISHES: **A, BSP, D, G**
 REPLACEMENT INSERT: **PK9 (BL, GR)**
 ANSI: **R3G414**

- Supplied Net Length (as ordered)

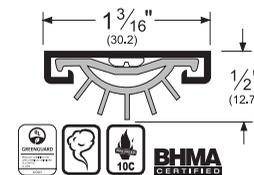

209_V

AVAILABLE FINISHES: **A, BSP, D**
 REPLACEMENT INSERT: **EV15 (BL, GR)**
 ANSI: **R3D414**

- Supplied Net Length (as ordered)

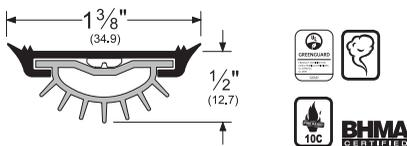

NOTE: Products shown in this section may not be drawn to scale.

AVAILABLE FINISHES FOR PRODUCTS SHOWN ON THIS PAGE

A (Mill Finish Aluminum) **BDG** (Bright Dip Gold Anodized) **BSP** (Black Suede Powder Coated Aluminum)
D (Dark Bronze Anodized) **G** (Gold Anodized) **PW** (Painted White)
SN (Satin Nickel Anodized) **WSP** (White Suede Powder Coated Aluminum)

800-824-3018 | www.pemko.com

Check the web site for the up-to-date catalog

Copyright © 2015-2024, ASSA ABLOY Accessories and Door Controls Group, Inc., an ASSA ABLOY Group company. All rights reserved.
 Reproduction in whole or in part without the express written permission of ASSA ABLOY Accessories and Door Controls Group, Inc. is prohibited.



Experience a safer
and more open world

DOOR SHOES (Cont.)

- Notched-fin gaskets (where applicable) allow up to 50% free air flow
- Recommended compression of gasket fins is 1/16"
- Except where noted, supplied with 1/4" undercut from length ordered. Specify "NET LENGTH" to receive length as ordered."

2173_V

AVAILABLE FINISHES: **A, BSP, D, G, WSP**
 AVAILABLE LENGTHS: **36", 48"**
 REPLACEMENT INSERT: **EV94 (BL)**
 ANSI: **R3D414, R3D415**

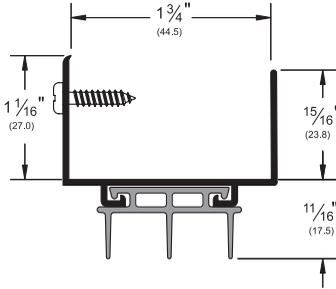

Also available with unnotched insert:
 2173_V36UN
 2173_V48UN

2343_V

AVAILABLE FINISHES: **A, BSP, D, G**
 AVAILABLE LENGTHS: **36", 48"**
 REPLACEMENT INSERT: **EV94 (BL)**
 ANSI: **R3D414, R3D415**

- Supplied Net Length (as ordered)

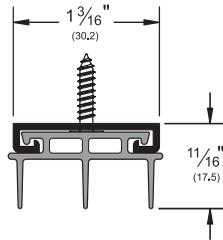

Also available with unnotched insert:
 2343_V36UN
 2343_V48UN

3692_PK773

AVAILABLE FINISHES: **A**
 AVAILABLE LENGTHS: **36", 48"**
 REPLACEMENT INSERT: **PK773 (BL, GR)**
 ANSI: **R3G414, R3G415**

- Supplied Net Length (as ordered)

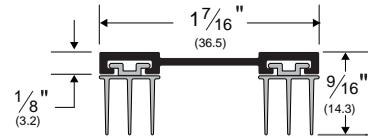

2113_V

AVAILABLE FINISHES: **A, BSP, D, G, WSP**
 AVAILABLE LENGTHS: **36", 48"**
 REPLACEMENT INSERT: **EV94 (BL)**
 ANSI: **R3D414, R3D415**

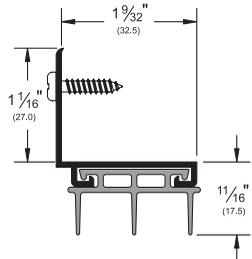

Also available with unnotched insert:
 2113_V36UN
 2113_V48UN

223_NB

AVAILABLE FINISHES: **A, BSP, WSP**
 REPLACEMENT INSERT: **P516041 (BL, GR)**
 ANSI: **R3A514, R3A515**

- Supplied Net Length (as ordered)

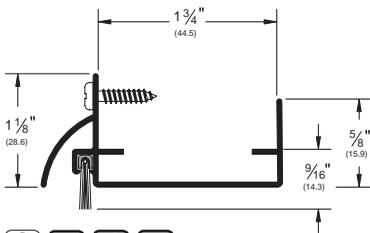

Replacement "V" gasket for Door Shoes on this page is EV94. For replacement gasket with notched fins, add "N" to the end of the part number.

Example:
 EV94BL-36.5 - Unnotched fins
 EV94BL-36.5N - Notched fins (for airflow)

NOTE: Products shown in this section may not be drawn to scale.

AVAILABLE FINISHES FOR PRODUCTS SHOWN ON THIS PAGE
A (Mill Finish Aluminum) **BSP** (Black Suede Powder Coated Aluminum)
D (Dark Bronze Anodized) **G** (Gold Anodized) **WSP** (White Suede Powder Coated Aluminum)



Experience a safer and more open world

800-824-3018 | www.pemko.com
 Check the web site for the up-to-date catalog

Copyright © 2015-2024, ASSA ABLOY Accessories and Door Controls Group, Inc., an ASSA ABLOY Group company. All rights reserved. Reproduction in whole or in part without the express written permission of ASSA ABLOY Accessories and Door Controls Group, Inc. is prohibited.

DOOR SHOES (Cont.)

2212_PK773

AVAILABLE FINISHES: **10BE, A, BSP, WSP**
 REPLACEMENT INSERT: **PK773 (BL)**
 ANSI: **R3G416**

- Combination door shoe and kick plate
- Excellent Acoustic performance
- Supplied Net Length (as ordered)

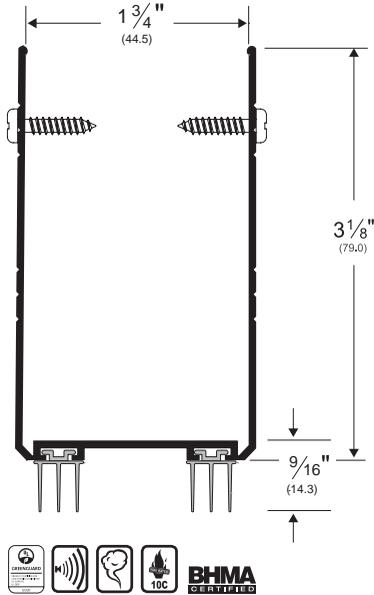

221_V

AVAILABLE FINISHES: **A, BSP, D, G, WSP**
 REPLACEMENT INSERT: **EV9 (BL, GR)**
 ANSI: **R3D414**

221_PK

AVAILABLE FINISHES: **A, BSP, D, G, WSP**
 REPLACEMENT INSERT: **PK9 (BL, GR)**
 ANSI: **R3G414**

- Combination door shoe and kick plate
- Supplied Net Length (as ordered)

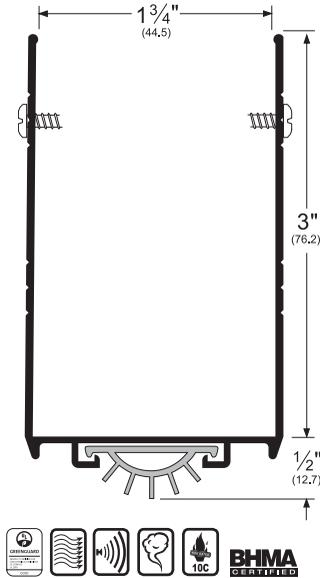

2211_V

AVAILABLE FINISHES: **A, BSP, D, G, WSP**
 REPLACEMENT INSERT: **EV9 (BL, GR)**
 ANSI: **R3D514**

2211_PK

AVAILABLE FINISHES: **A, BSP, D, G, WSP**
 REPLACEMENT INSERT: **PK9 (BL, GR)**
 ANSI: **R3G514**

- Combination door shoe and kick plate with rainrip
- Supplied Net Length (as ordered)

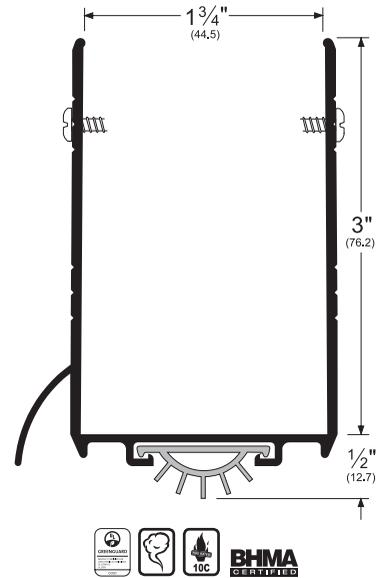

Thermally Broken Door Shoe

- Polypropylene thermal break (FG) prevents conductivity of hot or cold from exterior to interior.
- Supplied with PemkoPrene™ Seal
- Supplied Net Length (as ordered)

216_FG

AVAILABLE FINISHES: **A, BSP, D, SN, WSP**
 REPLACEMENT INSERT: **PK216 (BL, GR)**
 ANSI: **R3D514**

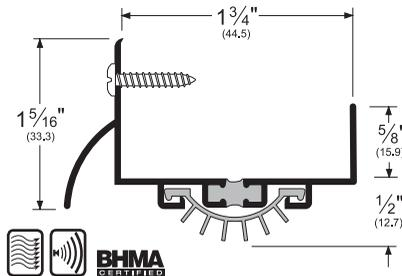

NOTE: Products shown in this section may not be drawn to scale.

AVAILABLE FINISHES FOR PRODUCTS SHOWN ON THIS PAGE

A (Mill Finish Aluminum) **BSP** (Black Suede Powder Coated Aluminum) **D** (Dark Bronze Anodized) **G** (Gold Anodized)
SN (Satin Nickel Anodized) **WSP** (White Suede Powder Coated Aluminum) **10BE** (Satin Bronze Powder Coated Aluminum)

800-824-3018 | www.pemko.com

Check the web site for the up-to-date catalog

Copyright © 2015-2024, ASSA ABLOY Accessories and Door Controls Group, Inc., an ASSA ABLOY Group company. All rights reserved.
 Reproduction in whole or in part without the express written permission of ASSA ABLOY Accessories and Door Controls Group, Inc. is prohibited.

PEMKO
ASSA ABLOY

Experience a safer
 and more open world

DOOR SWEEPS FOR HOLLOW METAL DOORS

- Profiles in this section available with PemkoPrene™ (PK) or Eco-V™ (V); both are the same shape and size
- Slotted holes for easy adjustment
- Rain drip model is ideal for deflecting rain away from the bottom of the door

222_V

AVAILABLE FINISHES: **A, BSP, D, WSP**
 REPLACEMENT INSERT: **EV9 (BL, GR)**
 ANSI: **R3D414**

222_PK

AVAILABLE FINISHES: **A, BSP, D, WSP**
 REPLACEMENT INSERT: **PK9 (BL, GR)**
 ANSI: **R3G414**

- For hollow metal doors with inverted bottom channel
- Supplied Net Length (as ordered)

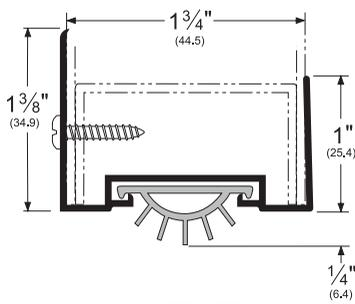

2221_V

AVAILABLE FINISHES: **A, BSP, D, G, WSP**
 REPLACEMENT INSERT: **EV9 (BL, GR)**
 ANSI: **R3D514**

2221_PK

AVAILABLE FINISHES: **A, BSP, D, G, WSP**
 REPLACEMENT INSERT: **EV9 (BL, GR)**
 ANSI: **R3G514**

- Supplied Net Length (as ordered)

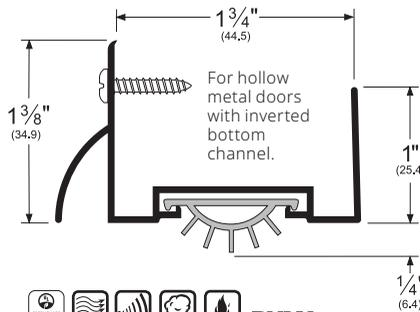

FABRICATION OPTIONS FOR DOOR SHOES

1/2" Full Notch

- Fabrication includes: removal of rain drip and front flange of door shoe to prevent interference with door stop and weatherstrip
- Ordering: order width of door leaf, and designate by adding "M" following the product number (Example: a 216AV with a 1/2" full notch fabrication, for a 36" door leaf = 216AVM36)

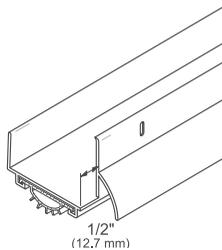

1/2" Half Notch

- Fabrication includes: removal of rain drip to prevent interference with door stop and weatherstrip
- Ordering: order width of door leaf and designate by adding "N" following the product number
- Special: Other half notches available are 9/16", 5/8", and 3/4" widths, please specify when ordering (Example: a 216AV with a 1/2" half notch fabrication, for a 36" door leaf = 216AVN36)

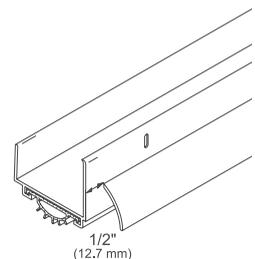

NOTE: Products shown in this section may not be drawn to scale.

AVAILABLE FINISHES FOR PRODUCTS SHOWN ON THIS PAGE

A (Mill Finish Aluminum) **BDC** (Bright Dip Clear Anodized) **BSP** (Black Suede Powder Coat)
D (Dark Bronze Anodized) **G** (Gold Anodized) **WSP** (White Suede Powder Coat)



Experience a safer
and more open world

800-824-3018 | www.pemko.com
 Check the web site for the up-to-date catalog

DOOR BOTTOM SWEEPS

315_N

AVAILABLE FINISHES: **B, BSP, C, D, WSP**
 REPLACEMENT INSERT: **E315 (BL)**
 ANSI: **R3B434, R3B435**

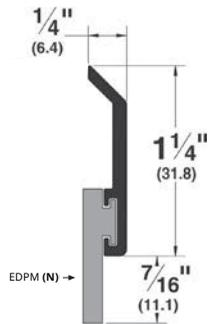

3151_N

AVAILABLE FINISHES: **BSP, C, D, G, WSP**
 REPLACEMENT INSERT: **E321 (BL)**
 ANSI: **R3B434**

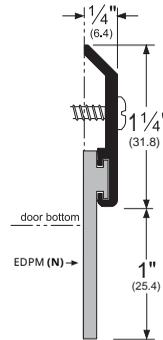

321_N

AVAILABLE FINISHES: **BSP, C, D, G, WSP**
 REPLACEMENT INSERT: **E321 (BL)**
 ANSI: **R3B434, R3B435**

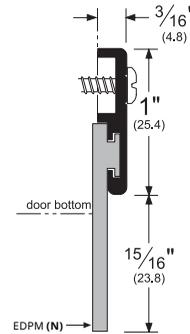

368_N

AVAILABLE FINISHES: **BSP, C, D, WSP**
 REPLACEMENT INSERT: **E368 (BL)**
 ANSI: **R3B434, R3B435**

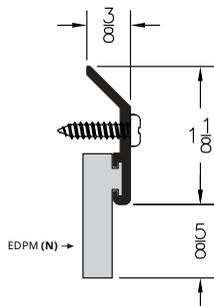

NOTE: Products shown in this section may not be drawn to scale.

AVAILABLE FINISHES FOR PRODUCTS SHOWN ON THIS PAGE

B (Mill Finish Extruded Bronze [Brass]) **BSP** (Black Suede Powder Coated Aluminum)
C (Clear Anodized) **D** (Dark Bronze Anodized) **G** (Gold Anodized) **WSP** (White Suede Powder Coated Aluminum)

800-824-3018 | www.pemko.com

Check the web site for the up-to-date catalog

Copyright © 2015-2024, ASSA ABLOY Accessories and Door Controls Group, Inc., an ASSA ABLOY Group company. All rights reserved.
 Reproduction in whole or in part without the express written permission of ASSA ABLOY Accessories and Door Controls Group, Inc. is prohibited.



Experience a safer
and more open world

DOOR BOTTOM SWEEPS (Cont.)

307_V

AVAILABLE FINISHES:
A, BSP, C, D, PW
 REPLACEMENT INSERT:
EV54 (BL, GR, W)
 ANSI: **R3D434**

307_PK

AVAILABLE FINISHES:
A, BSP, C, D, PW
 REPLACEMENT INSERT:
PK54 (BL, GR)
 ANSI: **R3G434**

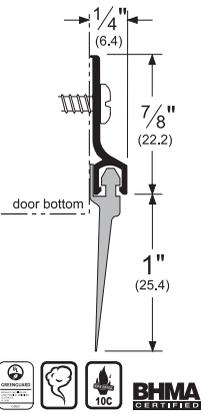

308_V

AVAILABLE FINISHES:
A, BSP, C, D, PW
 REPLACEMENT INSERT:
EV65 (BL, GR)
 ANSI: **R3D434**

308_PK

AVAILABLE FINISHES:
A, BSP, C, D, PW
 REPLACEMENT INSERT:
PK65 (BL, GR)
 ANSI: **R3D434**

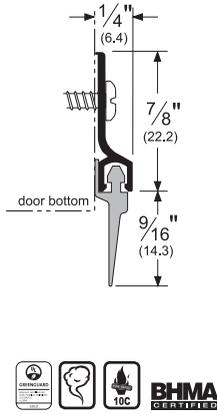

3452_V

AVAILABLE FINISHES:
A, BSP, C, D, WSP
 REPLACEMENT INSERT:
EV65 (BL, GR, W)
 ANSI: **R3D534**

3452_PK

AVAILABLE FINISHES:
A, BSP, C, D, WSP
 REPLACEMENT INSERT:
PK65 (BL, GR)
 ANSI: **R3G534**

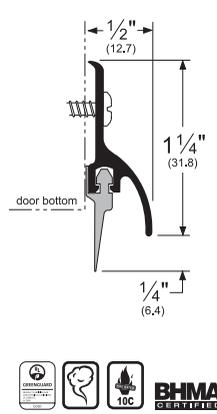

345_V

AVAILABLE FINISHES:
A, BSP, C, D, G, WSP
 REPLACEMENT INSERT:
EV54 (BL, GR, W)
 ANSI: **R3D534**

345_PK

AVAILABLE FINISHES:
A, BSP, C, D, G, WSP
 REPLACEMENT INSERT:
PK54 (BL, GR)
 ANSI: **R3G534**

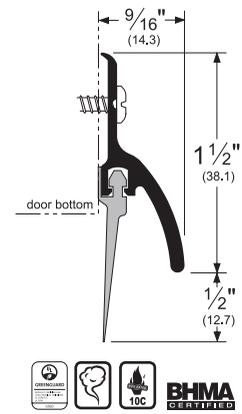

56_V

AVAILABLE FINISHES:
A, BSP, D, WSP
 REPLACEMENT INSERT:
EV56 (BL, GR)

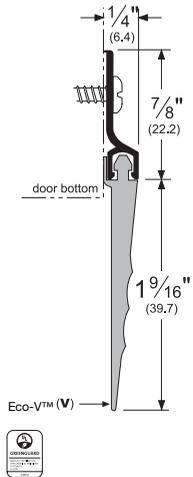

57_V

AVAILABLE FINISHES:
A, BSP, D, WSP
 REPLACEMENT INSERT:
EV57 (BL)

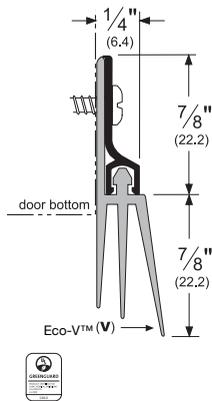

345_

AVAILABLE FINISHES:
A, B, BSP, C, D, G, WSP
 ANSI: **R3Y936**

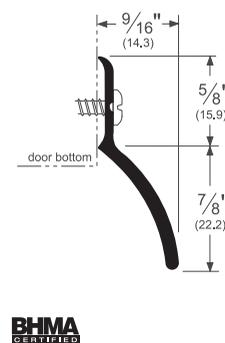

NOTE: Products shown in this section may not be drawn to scale.

AVAILABLE FINISHES FOR PRODUCTS SHOWN ON THIS PAGE
A (Mill Finish Aluminum) **B** (Mill Finish Extruded Bronze [Brass])
BSP (Black Suede Powder Coat) **C** (Clear Anodized) **D** (Dark Bronze Anodized)
G (Gold Anodized) **PW** (Painted White) **WSP** (White Suede Powder Coat)



Experience a safer
and more open world

800-824-3018 | www.pemko.com
 Check the web site for the up-to-date catalog

Copyright © 2015-2024, ASSA ABLOY Accessories and Door Controls Group, Inc., an ASSA ABLOY Group company. All rights reserved. Reproduction in whole or in part without the express written permission of ASSA ABLOY Accessories and Door Controls Group, Inc. is prohibited.

DOOR BOTTOM SWEEPS (Cont.)

3452_NB

AVAILABLE FINISHES:
BSP, C, D, G, WSP
 REPLACEMENT INSERT:
P14075 (BL, GR)
 ANSI: **R3A534**

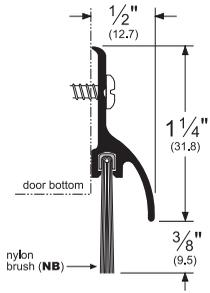

345_NB

AVAILABLE FINISHES:
A, BSP, D, G, WSP
 REPLACEMENT INSERT:
P14100 (BL, GR)
 ANSI: **R3A534**

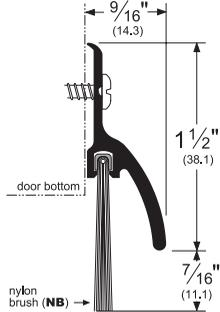

90062_NB

AVAILABLE FINISHES:
BSP, C, D, G, WSP
 REPLACEMENT INSERT:
P516062 (BL, GR, W)
 ANSI: **R3A414**

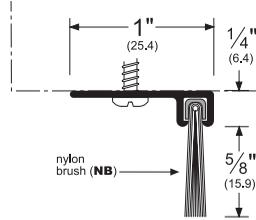

90100_NB

AVAILABLE FINISHES:
BSP, C, D, WSP
 REPLACEMENT INSERT:
P516100 (BL, GR, W)
 ANSI: **R3A414**

For hollow metal doors with inverted channel

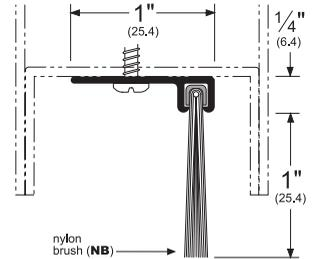

18061_NB

AVAILABLE FINISHES:
BSP, C, D, G, SN, WSP
 REPLACEMENT INSERT:
P516062 (BL, GR, W)
 ANSI: **R3A434**

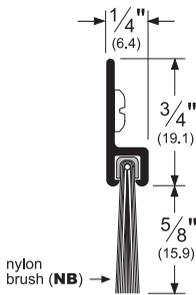

18100_NB

AVAILABLE FINISHES:
BSP, C, D, G, WSP
 REPLACEMENT INSERT:
P38100 (BL, GR)
 ANSI: **R3A434**

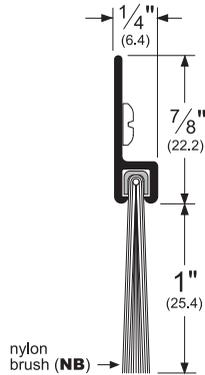

18137_NB

AVAILABLE FINISHES:
BSP, C, D, G, WSP
 REPLACEMENT INSERT:
P38137 (BL, GR)
 ANSI: **R3A434**

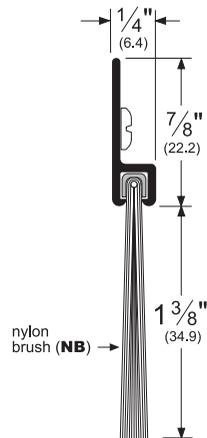

293100_NB

AVAILABLE FINISHES:
BSP, C, D, G, WSP
 REPLACEMENT INSERT:
P516100 (BL, GR)

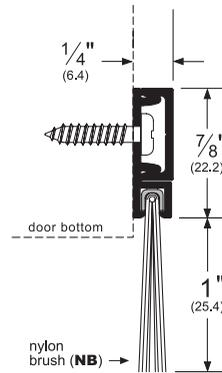

NOTE: Products shown in this section may not be drawn to scale.

AVAILABLE FINISHES FOR PRODUCTS SHOWN ON THIS PAGE

A (Mill Finish Aluminum) **BSP** (Black Suede Powder Coat) **C** (Clear Anodized)
D (Dark Bronze Anodized) **G** (Gold Anodized) **SN** (Satin Nickel Anodized)
WSP (White Suede Powder Coat)

800-824-3018 | www.pemko.com

Check the web site for the up-to-date catalog

Copyright © 2015-2024, ASSA ABLOY Accessories and Door Controls Group, Inc., an ASSA ABLOY Group company. All rights reserved.
 Reproduction in whole or in part without the express written permission of ASSA ABLOY Accessories and Door Controls Group, Inc. is prohibited.

PEMKO
ASSA ABLOY

Experience a safer
 and more open world

STAINLESS STEEL DOOR BOTTOM SWEEPS

315SSN

AVAILABLE FINISH: **SS (#4 Finish)**
 REPLACEMENT INSERT: **N8 (BL)**
 ANSI: **R5B434, R5B435**

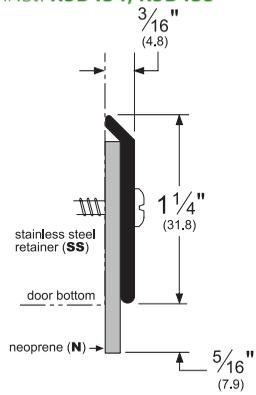

315SSR

AVAILABLE FINISH: **SS (#4 Finish)**
 REPLACEMENT INSERT: **ER2 (BL)**
 ANSI: **R5G164, R5G165**

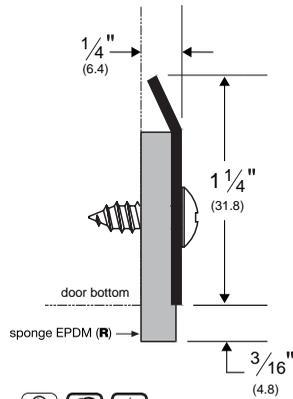

321SSN

AVAILABLE FINISH: **SS**
 REPLACEMENT INSERT: **N8 (BL)**
 ANSI: **R5B165**
 • 430 Bright Annealed SS

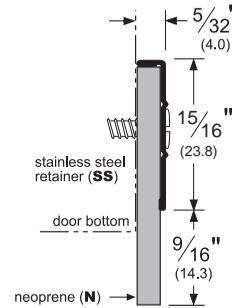

3151SSN

AVAILABLE FINISH: **SS (#4 Finish)**
 REPLACEMENT INSERT: **N9 (BL)**
 ANSI: **R5B434, R5B435**

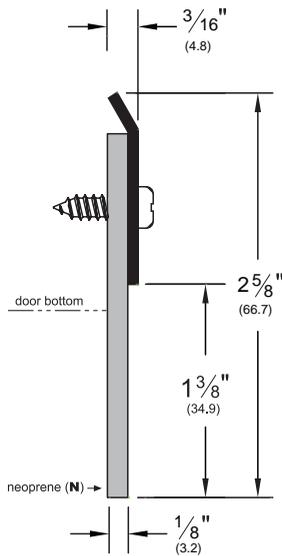

SPECIALTY DOOR SWEEP

• Talc-filled polypropylene body with flexible PemkoPrene® fin

SFSC200_

AVAILABLE FINISH: **BL, GR**

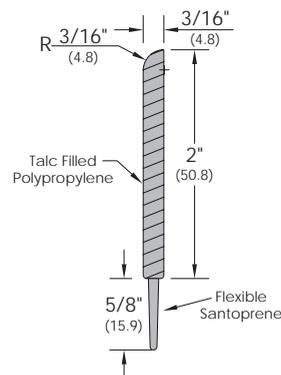

NOTE: Products shown in this section may not be drawn to scale.

AVAILABLE FINISHES FOR PRODUCTS SHOWN ON THIS PAGE
SS (See Individual Part)
 SFSC Finishes: **BL** (Black), **GR** (Gray)



Experience a safer
and more open world

800-824-3018 | www.pemko.com
 Check the web site for the up-to-date catalog

SPECIALTY DOOR BOTTOMS

- May be used in many different applications. Some of these shapes may be used as meeting stile gasketing; see page 174 for examples
- Supplied Net Length (as ordered)

313_N

AVAILABLE FINISHES: **A, D, G**
 REPLACEMENT INSERT:
E1 (BL, GR)
 ANSI: **R3G416**

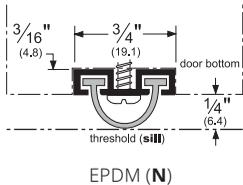

317_N

AVAILABLE FINISHES: **A, BSP, D**
 REPLACEMENT INSERT: **E1 (BL, GR)**
 ANSI: **R3G416**

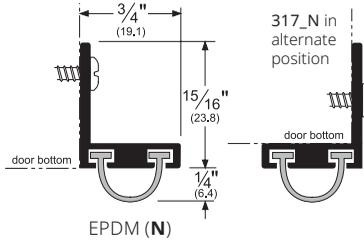

314_N

AVAILABLE FINISHES: **C, D, G**
 REPLACEMENT INSERT: **E3 (BL, GR)**
 ANSI: **R3G416**

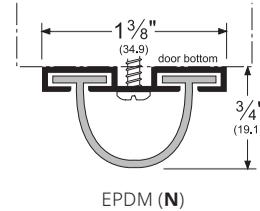

DOOR TOP WEATHERSTRIP

_344

AVAILABLE FINISHES: **PA**
 AVAILABLE LENGTHS: **36", 48"**

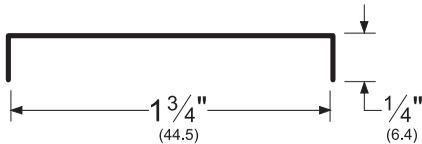

346_

AVAILABLE FINISHES: **10BE, BSP, C, D, WSP**

- Overhead rain drip with slotted holes
- Should be ordered a minimum of 4" longer than the door width

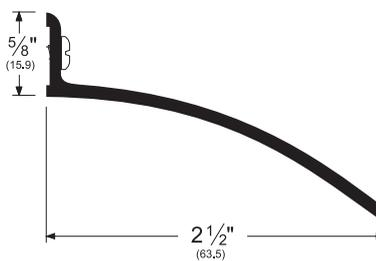

347_68_R

AVAILABLE FINISHES: **A, D, G**

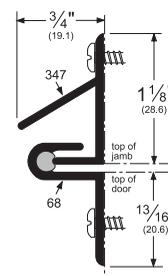

HEAVY DUTY DOOR BUMPER

- Heavy duty door bumper extruded from black EPDM (E)
- Order 196_ separately; furnished undrilled unless requested otherwise

E199_

AVAILABLE COLOR: **BL**



196_

AVAILABLE COLOR: **A**

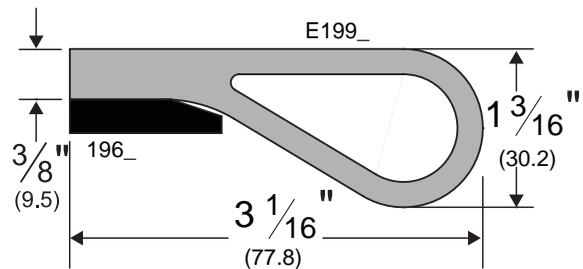

NOTE: Products shown in this section may not be drawn to scale.

AVAILABLE FINISHES FOR PRODUCTS SHOWN ON THIS PAGE

10BE (Satin Bronze Powder Coated Aluminum) **A** (Mill Finish Aluminum) **BSP** (Black Suede Powder Coated Aluminum)
C (Clear Anodized) **D** (Dark Bronze Anodized) **G** (Gold Anodized) **PA** (Painted Aluminum)
WSP (White Suede Powder Coated Aluminum)

Non-Metal Finish: **BL** (Black)

800-824-3018 | www.pemko.com

Check the web site for the up-to-date catalog

Copyright © 2015-2024, ASSA ABLOY Accessories and Door Controls Group, Inc., an ASSA ABLOY Group company. All rights reserved.
 Reproduction in whole or in part without the express written permission of ASSA ABLOY Accessories and Door Controls Group, Inc. is prohibited.



Experience a safer
 and more open world



Experience a safer
and more open world

PEMKO ASTRAGALS & MEETING STILES

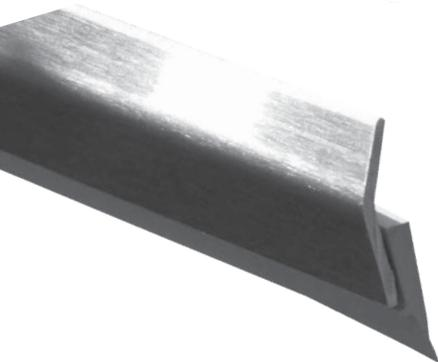

CONTENTS:

Astragal and Meeting Stile Gasketing - Split Astragals.....	150
Split Astragals with Snap Covers – Concealed Fasteners.....	152
Meeting Stile Gasketing.....	152
Adhesive Astragal/Meeting Stile Seals	154
Adjustable Astragals.....	154
“T” and Overlapping Astragals.....	155
Adhesive-Backed Mullion Gasketing.....	156
Adhesive-Backed Astragal Seal	156
Offset Security Bar	156
Locking Astragals	157
Outswing Locking Astragals	159

INDEX:

PRODUCT	PAGE	PRODUCT	PAGE	PRODUCT	PAGE
297.....	150	356	155	3572	156
300	153	357	155	5110.....	156
303	150	359.....	155	18041.....	151
305	150	369	153	18061.....	151
305SS.....	150	371.....	153	29310.....	152
310.....	151	372.....	153	29324.....	152
311CIN.....	151	375.....	155	29326.....	152
313.....	152	3443.....	159	S771	154
314.....	152	3444.....	159	S771x6.....	154
316.....	151	3493.....	156	S772.....	154
351.....	154	3494.....	156	S1125	156
354	154	3495.....	158		
355	155	3496.....	158		

ASTRAGAL AND MEETING STILE GASKETING – SPLIT ASTRAGALS

- Astragals and meeting stiles with a fire label may be mounted on pairs of doors wherein the gap meets the requirements of **NFPA 80, 6.3.1.7.1 "The clearance between... the meeting edges of doors swinging in pairs on the pull side shall be 1/8" ± 1/16" (3.18mm ± 1.59mm) for steel doors and shall not exceed 1/8" (3.18mm) for wood doors"**
- Punched with slotted holes for adjustment

- Order split astragals at two (2) pieces by door height per set of double doors. When ordering add "72" to the end of the part number to specify 2 pieces (i.e. order quantity 1 each 303AS84/2 to get two lengths at 84 inches)
- Clear anodized brush products are supplied with gray brush. Painted white brush products are supplied with white brush when available, otherwise black brush is supplied. All other finishes supplied with black brush. Black brush is available for clear anodized and painted white brush products upon request.

297_S

AVAILABLE FINISHES:
10BE, A, BDG, BSP, D, PW, SN, WSP
 REPLACEMENT INSERT:
S3 (BL, W)
 ANSI: **R3E734, R3E735**

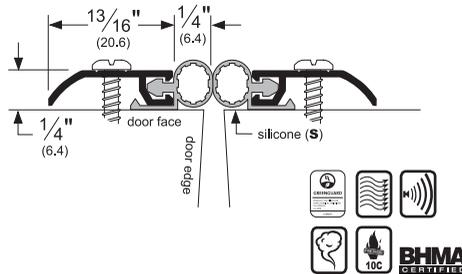

303_S

AVAILABLE FINISHES:
10BE, A, BSP, C, D, G, PW, SN, WSP
 REPLACEMENT INSERT:
S3 (BL, W)
 ANSI: **R3E734, R3E735**

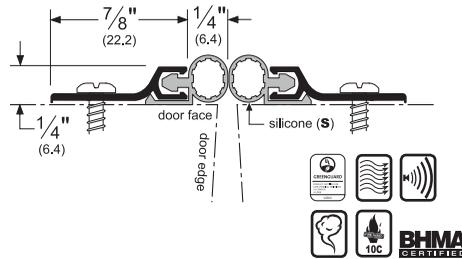

305_N

AVAILABLE FINISHES:
10BE, B, BSP, C, D, WSP
 REPLACEMENT INSERT:
E2 (BL)
 ANSI: **R3G734, R3G735**

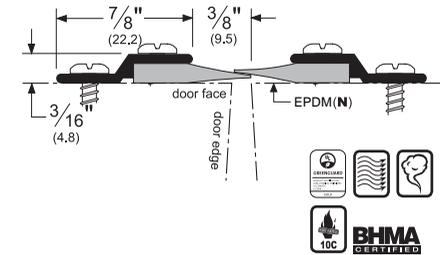

305SSE

AVAILABLE FINISHES:
SS (#4 Finish)
 REPLACEMENT INSERT:
E2 (BL)
 ANSI: **R5G734, R5G735**

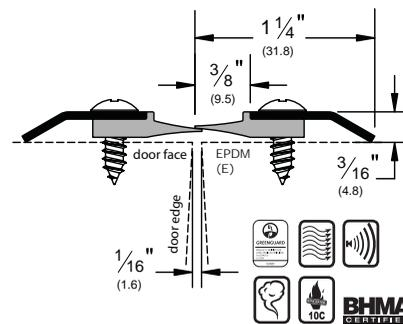

Alternate Inserts For 297

297_PK

AVAILABLE FINISHES:
10BE, A, BDG, BSP, D, PW, SN, WSP
 REPLACEMENT INSERT:
PK47 (BL, GR)
 ANSI: **R3G734, R3G735**

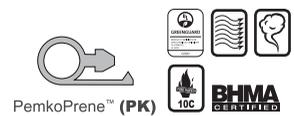

297_V

AVAILABLE FINISHES:
10BE, A, BDG, BSP, D, PW, SN, WSP
 REPLACEMENT INSERT:
EV47 (BL, GR, W)

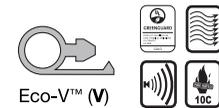

Alternate Inserts For 303

303_PK

AVAILABLE FINISHES:
10BE, A, BSP, C, D, G, PW, SN, WSP
 REPLACEMENT INSERT:
PK47 (BL, GR)
 ANSI: **R3G734**

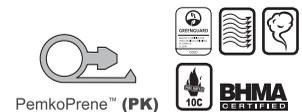

303_V

AVAILABLE FINISHES:
10BE, A, BSP, C, D, G, PW, SN, WSP
 REPLACEMENT INSERT:
EV47 (BL, GR, W)



AVAILABLE FINISHES FOR PRODUCTS SHOWN ON THIS PAGE

10BE (Satin Bronze Powder Coated Aluminum) **A** (Mill Finish Aluminum) **BDG** (Bright Dip Gold Anodized)
BSP (Black Suede Powder Coated Aluminum) **C** (Clear Anodized) **D** (Dark Bronze Anodized) **G** (Gold Anodized)
PW (Painted White) **SN** (Satin Nickel Anodized) **WSP** (White Suede Powder Coated Aluminum)



Experience a safer and more open world

800-824-3018 | www.pemko.com
 Check the web site for the up-to-date catalog

Copyright © 2015-2024, ASSA ABLOY Accessories and Door Controls Group, Inc., an ASSA ABLOY Group company. All rights reserved. Reproduction in whole or in part without the express written permission of ASSA ABLOY Accessories and Door Controls Group, Inc. is prohibited.

ASTRAGAL AND MEETING STILE GASKETING – SPLIT ASTRAGALS (Cont.)

316_S

AVAILABLE FINISHES:
10BE, A, BSP, D, G, WSP
 REPLACEMENT INSERT:
S3 (BL, W)
 ANSI: **R3E734, R3E735**

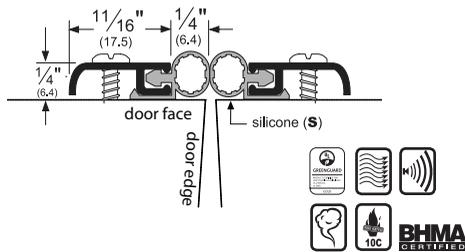

Alternate Inserts For 316

316_PK

AVAILABLE FINISHES:
10BE, A, BSP, D, G, WSP
 REPLACEMENT INSERT:
PK47 (BL, GR)
 ANSI: **R3G734, R3G735**



PemkoPrene™ (PK)



316_V

AVAILABLE FINISHES:
10BE, A, BSP, D, G, WSP
 REPLACEMENT INSERT:
EV47 (BL, GR, W)



Eco-V™ (V)



18041_NB

AVAILABLE FINISHES:
10BE, C, BSP, D, G, SN, WSP
 REPLACEMENT INSERT:
P516041 (BL, GR)
 ANSI: **R3A734**

NOTE: Brush should mesh from 1/32" to 1/16".

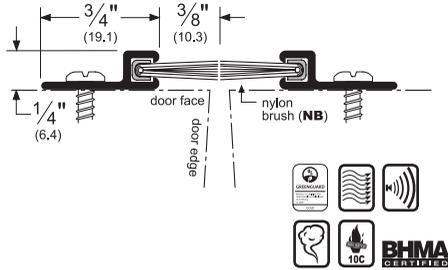

Alternate Inserts For 18041

18041_SB

AVAILABLE FINISHES:
10BE, C, BSP, D, G, SN, WSP
 REPLACEMENT INSERT:
P3 (BL, GR)



soft brush (SB)

18061_NB

AVAILABLE FINISHES:
10BE, C, BSP, D, G, SN, WSP
 REPLACEMENT INSERT:
P516062 (BL, GR, W)
 ANSI: **R3A734**

NOTE: Brush should mesh from 1/32" to 1/16".

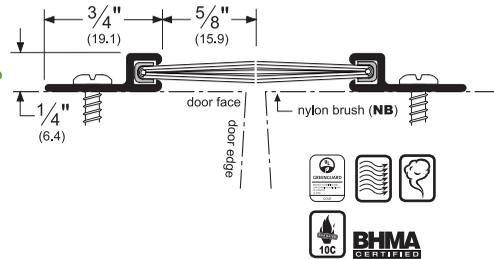

310_*

311CIN

AVAILABLE FINISHES:
C

- Material required for one pair of doors:
 - 4 ea. 310 bars and
 - 2 ea. 311CIN cloth inserted rubber pieces
 - Specify 311CIN3.75 for 1 3/4" thick doors
 - Specify 311CIN4.00 for 2" thick doors
 - Specify 311CIN4.25 for 2 1/4" thick doors

* Sold individually

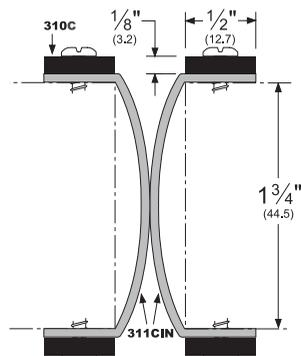

AVAILABLE FINISHES FOR PRODUCTS SHOWN ON THIS PAGE

10BE (Satin Bronze Powder Coated Aluminum) **A** (Mill Finish Aluminum)
BSP (Black Suede Powder Coated Aluminum) **C** (Clear Anodized) **D** (Dark Bronze Anodized)
G (Gold Anodized) **SN** (Satin Nickel Anodized) **WSP** (White Suede Powder Coated Aluminum)

800-824-3018 | www.pemko.com

Check the web site for the up-to-date catalog

Copyright © 2015-2024, ASSA ABLOY Accessories and Door Controls Group, Inc., an ASSA ABLOY Group company. All rights reserved.
 Reproduction in whole or in part without the express written permission of ASSA ABLOY Accessories and Door Controls Group, Inc. is prohibited.

PEMKO
ASSA ABLOY

Experience a safer
 and more open world

SPLIT ASTRAGALS WITH SNAP COVERS – CONCEALED FASTENERS

- Snap cover helps prevent vandalism and adds an attractive finished look by concealing the fasteners
- Replacement snap cover part number is _29316. Please specify finish and length when ordering.

29310_S

AVAILABLE FINISHES:
10BE, BSP, C, D, G, WSP
 REPLACEMENT INSERT:
S4 (BL, GR)
 ANSI: **R3E734**

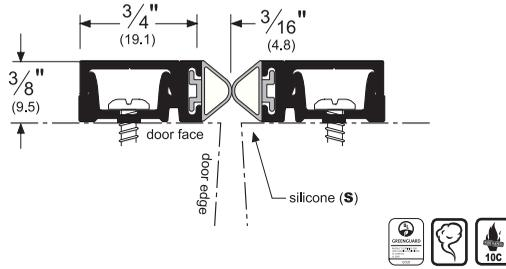

29324_NB

AVAILABLE FINISHES:
10BE, BSP, C, D, G, WSP
 REPLACEMENT INSERT:
P516041 (BL, GR)
 ANSI: **R3A434**

NOTE: Brush should mesh from 1/32" to 1/16".

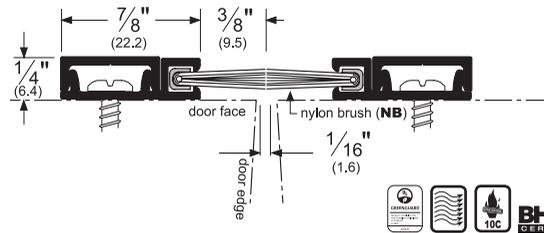

29326_NB

AVAILABLE FINISHES:
10BE, BSP, C, D, G, WSP
 REPLACEMENT INSERT:
P516062 (BL, GR, W)
 ANSI: **R3A164, R3A165**

NOTE: Brush should mesh from 1/32" to 1/16".

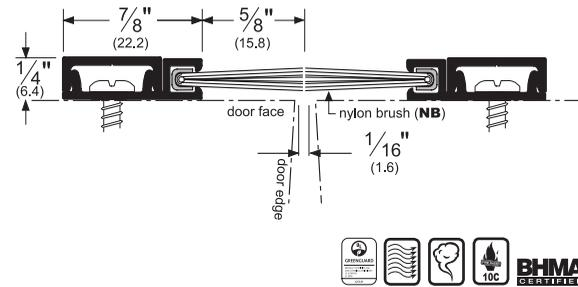

Alternate Inserts For 29310

29310_PK

AVAILABLE FINISHES:
10BE, BSP, C, D, G, WSP
 REPLACEMENT INSERT:
S4 (BL, GR)
 ANSI: **R3G734**



29310_P

AVAILABLE FINISHES:
10BE, BSP, C, D, G, WSP
 REPLACEMENT INSERT:
P2 (BL, GR)



29310_V

AVAILABLE FINISHES:
10BE, BSP, C, D, G, WSP
 REPLACEMENT INSERT:
EV41 (BL, GR, W)



Alternate Inserts For 29324

29324_SB

AVAILABLE FINISHES:
10BE, BSP, C, D, G, WSP
 REPLACEMENT INSERT:
P3 (BL, GR)



MEETING STILE GASKETING

- These products do not work well on beveled-edge pairs of doors

313_N

AVAILABLE FINISHES:
A, D, G
 REPLACEMENT INSERT:
E1 (BL, GR)

NOTE: Recommended radius is 1-7/8"

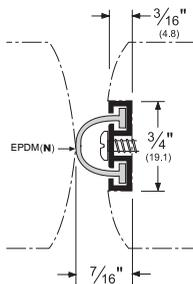

314_N

AVAILABLE FINISHES:
C, D, G
 REPLACEMENT INSERT:
E3 (BL, GR)

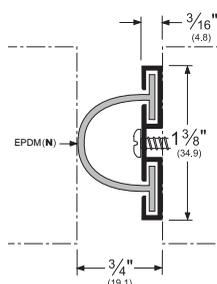

Experience a safer
and more open world

AVAILABLE FINISHES FOR PRODUCTS SHOWN ON THIS PAGE

10BE (Satin Bronze Powder Coated Aluminum) **A** (Mill Finish Aluminum) **BSP** (Black Suede Powder Coated Aluminum) **C** (Clear Anodized) **D** (Dark Bronze Anodized) **G** (Gold Anodized) **WSP** (White Suede Powder Coated Aluminum)

800-824-3018 | www.pemko.com

Check the web site for the up-to-date catalog

Copyright © 2015-2024, ASSA ABLOY Accessories and Door Controls Group, Inc., an ASSA ABLOY Group company. All rights reserved. Reproduction in whole or in part without the express written permission of ASSA ABLOY Accessories and Door Controls Group, Inc. is prohibited.

MEETING STILE GASKETING (Cont.)

• Astragals/Meeting Stiles with a fire label may be mounted on pairs of doors wherein the gap meets the requirements of NFPA 80, 2-5.4

• These products do not work well on beveled-edge pairs of doors

369_P

AVAILABLE FINISHES: **A, D, G**
REPLACEMENT INSERT:
P2 (BL, GR)

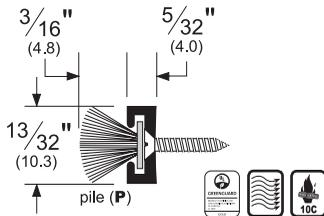

369_PK

AVAILABLE FINISHES: **A, D, G**
REPLACEMENT INSERT:
S4 (BL, GR)

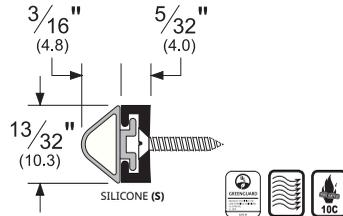

369_S

AVAILABLE FINISHES: **A, D, G**
REPLACEMENT INSERT:
S4 (BL, GR)

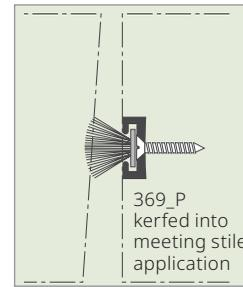
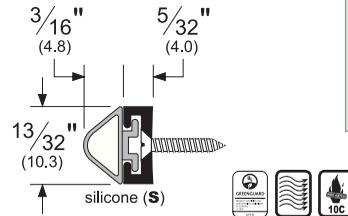

369_P4

AVAILABLE FINISHES: **A, D, G**
REPLACEMENT INSERT:
P4 (BL)

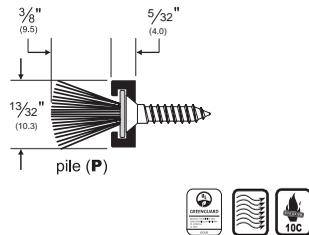

369_PK773

AVAILABLE FINISHES: **A, D, G**
REPLACEMENT INSERT:
PK773 (BL)

• Gasket only available in 36" or 49" lengths and will be spliced a continuous metal retainer

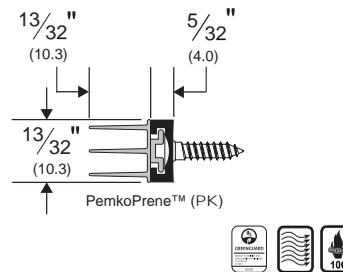

369_V

AVAILABLE FINISHES: **A, D, G**
REPLACEMENT INSERT:
EV41 (BL, GR, W)

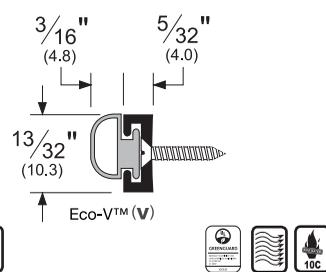

A371P (1/4" pile)

A372P (3/8" pile)

- Available in 84" and 96" lengths
- Available with gray pile only
- Fasten with nails or staples through pile and backing, or use adhesive. Fasteners not supplied
- Pile and backing do not separate

300_P

AVAILABLE FINISHES:
B, C, D, G
REPLACEMENT INSERT:
P2 (BL, GR)

- For a 3/8" gap (or smaller) between doors
- Spring-loaded from back side

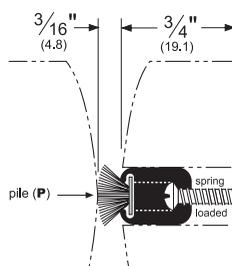
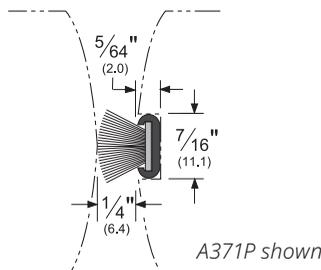

AVAILABLE FINISHES FOR PRODUCTS SHOWN ON THIS PAGE
A (Mill Finish Aluminum) **B** (Mill Finish Extruded Bronze [Brass]) **C** (Clear Anodized)
D (Dark Bronze Anodized) **G** (Gold Anodized)

800-824-3018 | www.pemko.com

Check the web site for the up-to-date catalog

Copyright © 2015-2024, ASSA ABLOY Accessories and Door Controls Group, Inc., an ASSA ABLOY Group company. All rights reserved.
Reproduction in whole or in part without the express written permission of ASSA ABLOY Accessories and Door Controls Group, Inc. is prohibited.

PEMKO
ASSA ABLOY

Experience a safer
and more open world

ADHESIVE ASTRAGAL/MEETING STILE SEALS

- The **S771** and **S772** astragal/meeting stile seals can be installed on virtually any pair of doors where sound attenuation is required. These products seal the opening to prevent heat loss, retard the passage of smoke, and act as a weatherization product
- Excellent resistance to compression set, particularly at elevated temperatures and for extended periods of time
- Stays flexible between -58°F and 450°F with very high resistance to flex fatigue
- Maintains a low closing force
- Easy installation requires no mechanical fasteners; can be cut to size in the field

S771_

AVAILABLE FINISHES: **BL, C, D, W**
 AVAILABLE LENGTHS: **7', 8', 9', 10'**
 ANSI: **ROE754, ROE755**

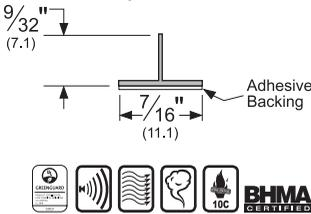

S772_

AVAILABLE FINISHES: **BL, C, D, W**
 AVAILABLE LENGTHS: **7', 8', 9', 10'**
 ANSI: **ROE754, ROE755**

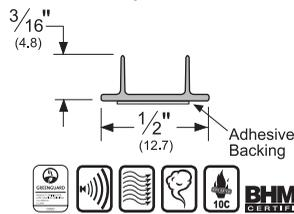

S771x6_

AVAILABLE FINISHES: **BL**
 AVAILABLE LENGTHS: **7', 8', 9', 10'**
 ANSI: **ROE154, ROE155, ROE754, ROE755**

- Designed for hollow metal and wood meeting stile applications
- Seal begins compressing at $5/16$ "

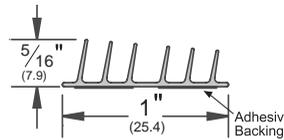

Notes For All Adhesive Gasketing:

Storage and shelf life: All adhesive gaskets have a limited shelf life. This product must be installed within 6 months of purchase and must be stored between 50°F and 100°F. For further notes/details, please see Adhesive Gasketing section.

ADJUSTABLE ASTRAGALS

- Available in 84", 96" and 120" lengths
- When used as split astragals on double doors, two lengths must be ordered: one for each door
- If you require split astragals in a metal to gasket configuration, you must order using part number 351_/351_S where "S" can be any gasket designation shown in this section and "_" is your desired finish

351_S

AVAILABLE FINISHES:
10BE, B, BSP, C, D, G, WSP
 REPLACEMENT INSERT:
S4 (BL, GR)

- Surface applied
- For use with square-edge or bevel-edge doors
- 351_S (et al) is one single piece; order 351_/351_S to receive both pieces as in drawing

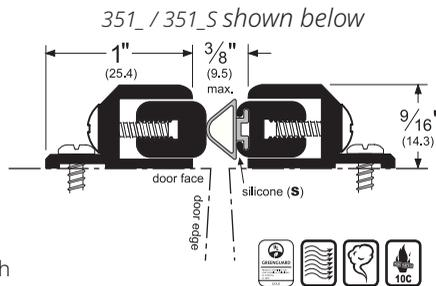

354_S

AVAILABLE FINISHES:
10BE, B, BSP, C, D, G, WSP
 REPLACEMENT INSERT:
S4 (BL, GR)

- Fully mortised
- Designed for use with bullnose doors
- 354_S (et al) is one single piece; order 354_/354_S to receive both pieces as in drawing

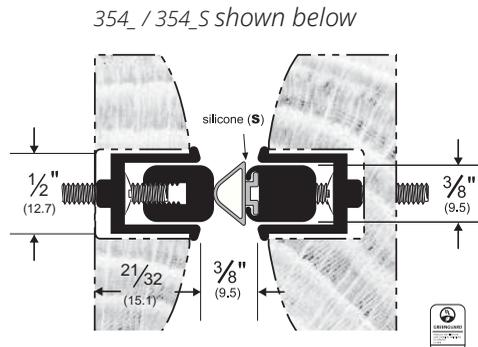

Alternate Inserts For 351

351_PK

AVAILABLE FINISHES:
10BE, B, BSP, C, D, G, WSP
 REPLACEMENT INSERT:
S4 (BL, GR)



351_V

AVAILABLE FINISHES:
10BE, B, BSP, C, D, G, WSP
 REPLACEMENT INSERT:
EV41 (BL, GR, W)

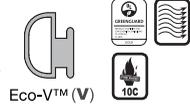

351_P

AVAILABLE FINISHES:
10BE, B, BSP, C, D, G, WSP
 REPLACEMENT INSERT:
P2 (BL, GR)

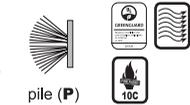

Alternate Inserts For 354

354_PK

AVAILABLE FINISHES:
10BE, B, BSP, C, D, G, WSP
 REPLACEMENT INSERT:
S4 (BL, GR)



354_V

AVAILABLE FINISHES:
10BE, B, BSP, C, D, G, WSP
 REPLACEMENT INSERT:
EV41 (BL, GR, W)



354_P

AVAILABLE FINISHES:
10BE, B, BSP, C, D, G, WSP
 REPLACEMENT INSERT:
P2 (BL, GR)

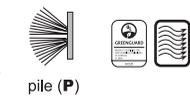

AVAILABLE FINISHES FOR PRODUCTS SHOWN ON THIS PAGE

10BE (Satin Bronze Powder Coated Aluminum) **B** (Mill Finish Extruded Bronze [Brass]) **BSP** (Black Suede Powder Coated Aluminum) **C** (Clear Anodized) **D** (Dark Bronze Anodized) **G** (Gold Anodized) **WSP** (White Suede Powder Coated Aluminum)
 Gasket colors: **BL** (Black) **C** (Clear) **D** (Dark) **GR** (Gray) **W** (White)



Experience a safer
and more open world

"T" AND OVERLAPPING ASTRAGALS

359_
 AVAILABLE FINISHES: **10BE, A, BSP, D, WSP**
 • Supplied with weatherstrip nails for installation

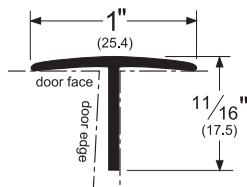

356_V
 AVAILABLE FINISHES: **10BE, A, BDG, BSP, D, PW, WSP**
 REPLACEMENT INSERT: **EV17 (BL, GR, W)**
 • Countersink drilling with countersunk flathead screws also available upon request at no extra charge

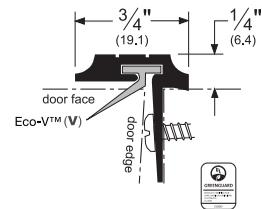

355_S
 AVAILABLE FINISHES: **10BE, B, BSP, C, D, PW, WSP**
 REPLACEMENT INSERT: **S4 (BL, GR)**

Alternate Inserts For 355

355_V
 AVAILABLE FINISHES: **10BE, B, BSP, C, D, PW, WSP**
 REPLACEMENT INSERT: **EV7 (BL, GR, W)**

355_P
 AVAILABLE FINISHES: **10BE, B, BSP, C, D, PW, WSP**
 REPLACEMENT INSERT: **P2 (BL, GR)**

355_PK
 AVAILABLE FINISHES: **10BE, B, BSP, C, D, PW, WSP**
 REPLACEMENT INSERT: **PK7 (BL, GR)**

357_
357_ND
 AVAILABLE FINISHES: **10BE, BSP, C, D, SP, SPBSP, SPWSP**
SS (#4 Finish & #4 Edge)

11 GAUGE

- "ND" denotes "no drill" (unless specified "ND", astragals are drilled)
- Standard fastener is #10 x 1" Truss Head SMS
- Lead-line option available

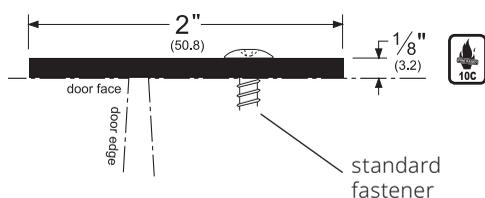

357_ with S88
 AVAILABLE FINISHES: **SP, SS (#4 Finish & #4 Edge)**

11 GAUGE

- Standard fastener is #10 x 1" Truss Head SMS
- 1/4" - 20 machine screws and thru-bolts must be ordered separately at additional cost
- S88 seal must be ordered separately at an additional cost, if required

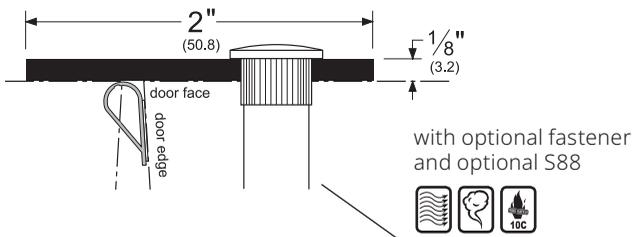

375_R
 AVAILABLE FINISHES: **10BE, BSP, C, D, WSP**
 REPLACEMENT INSERT: **ER6 (BL)**
 ANSI: **R3C634, R3C635**

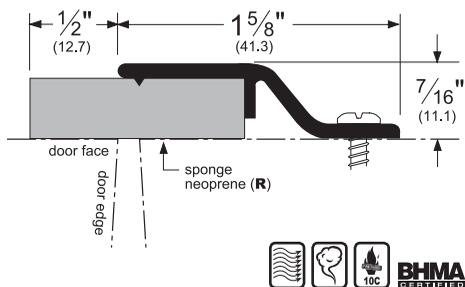

AVAILABLE FINISHES FOR PRODUCTS SHOWN ON THIS PAGE
10BE (Satin Bronze Powder Coated Aluminum) **A** (Mill Finish Aluminum) **B** (Mill Finish Extruded Bronze [Brass])
BDG (Bright Dip Gold Anodized) **C** (Clear Anodized) **BSP** (Black Suede Powder Coated Aluminum) **D** (Dark Bronze Anodized)
PW (Painted White) **SP** (Galvannealed Steel) **SPBSP** (Black Suede Powder Coated Steel)
SPWSP (White Suede Powder Coated Steel) **SS** (See Individual Part) **WSP** (White Suede Powder Coated Aluminum)

800-824-3018 | www.pemko.com

Check the web site for the up-to-date catalog

Copyright © 2015-2024, ASSA ABLOY Accessories and Door Controls Group, Inc., an ASSA ABLOY Group company. All rights reserved.
 Reproduction in whole or in part without the express written permission of ASSA ABLOY Accessories and Door Controls Group, Inc. is prohibited.

PEMKO
ASSA ABLOY

Experience a safer
 and more open world

ADHESIVE-BACKED MULLION GASKETING

5110_
 AVAILABLE FINISH: **BL**
 AVAILABLE LENGTHS: **120"**
 ANSI: **R0C004**

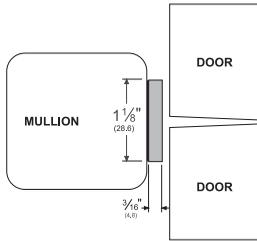
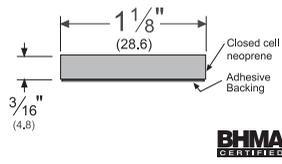

ADHESIVE-BACKED ASTRAGAL SEAL

S1125_
 AVAILABLE FINISH: **D**
 AVAILABLE LENGTHS: **7', 8', 10'**

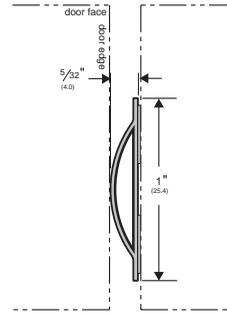
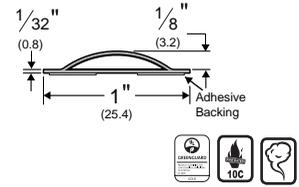

OFFSET SECURITY BAR

- For use on single outswing wood or metal doors
- Covers gap between the door and jamb for the full door height, preventing prying and manipulation

3572_
 3572_ND
 AVAILABLE FINISHES:
SP, SPBSP, SPWSP,
SS (#4 Finish & #4 Edge)
 AVAILABLE LENGTHS:
80", 84" and 96"
10 GAUGE

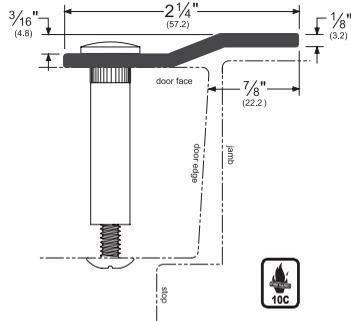

- 3572_ supplied drilled 12" on center with 3/8" holes; "ND" denotes "no drill"

3572PP7
 3572PP7ND
 AVAILABLE FINISHES:
PP
 AVAILABLE LENGTHS:
84"
7 GAUGE

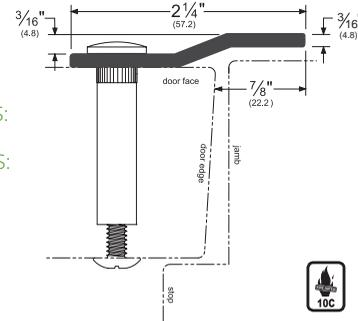

Experience a safer
and more open world

AVAILABLE FINISHES FOR PRODUCTS SHOWN ON THIS PAGE
BL (Black) **D** (Dark Brown) **PP** (Prime Painted) **SP** (Galvanized Steel)
SS (See Individual Part) **SPBSP** (Black Suede Powder Coated Steel)
SPWSP (White Suede Powder Coated Steel)

800-824-3018 | www.pemko.com
 Check the web site for the up-to-date catalog

Copyright © 2015-2024, ASSA ABLOY Accessories and Door Controls Group, Inc., an ASSA ABLOY Group company. All rights reserved.
 Reproduction in whole or in part without the express written permission of ASSA ABLOY Accessories and Door Controls Group, Inc. is prohibited.

LOCKING ASTRAGALS

- Weatherstripped astragals with locking spring bolts or slide bolts for 1 $\frac{3}{4}$ " inswing double doors
- Odd numbered astragals have economical smooth acting slide bolts. Slide bolts are 4" from the top/bottom standard; optional 18" slide bolt is available for easier access. Even numbered astragals have locking spring bolts. Both have full $\frac{3}{8}$ " diameter steel bolts with 1 $\frac{1}{16}$ " throw. In the extended and locked position, locking spring bolts cannot be easily retracted by tampering. In the retracted position, the spring loaded bolts latch firmly, preventing marking of the floor and door header trim when opening or closing the inactive door
- Styles **3493** thru **3498** come with a molded sponge neoprene bottom seal
- All feature four-way adjustable strike plate mounting for latchbolt and deadbolt
- All come with a Eco-V™ snap-in cover strip to conceal the cutout and cover the mounting screws
- Astragal stock lengths are 80", 84", 96" and 120"
- A standard deadbolt punchout is $\frac{3}{4}$ " x 4" at 40" on center Punchout supplied on request only
- For non-stock astragals, specify deadbolt punchout size and center distance from top end
- Specify handing using the handing chart on page 181 or 184

Handing Chart For Astragals (For pages 169 thru 171)

- An astragal is handed by the hand of the active door. The hand of the active door is determined by the position of the hinges on the door, when viewed from the outside (the key side)

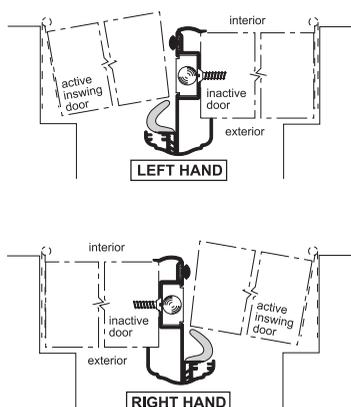

Slimline style with slide bolt 3493_S

REPLACEMENT INSERT: **S4 (BL, GR)**

3493_V

REPLACEMENT INSERT: **EV41 (BL, W)**

AVAILABLE FINISHES:

C, D, G, PW

- **3493** also available with 18" slide bolt (at additional cost) for easier access (specify "L" at the end of the product number for this option i.e. **3493_VL**)

Slimline style with locking spring bolt 3494_S

REPLACEMENT INSERT: **S4 (BL, GR)**

3494_V

REPLACEMENT INSERT: **EV41 (BL, W)**

AVAILABLE FINISHES:

C, D, G, PW

Slimline Style

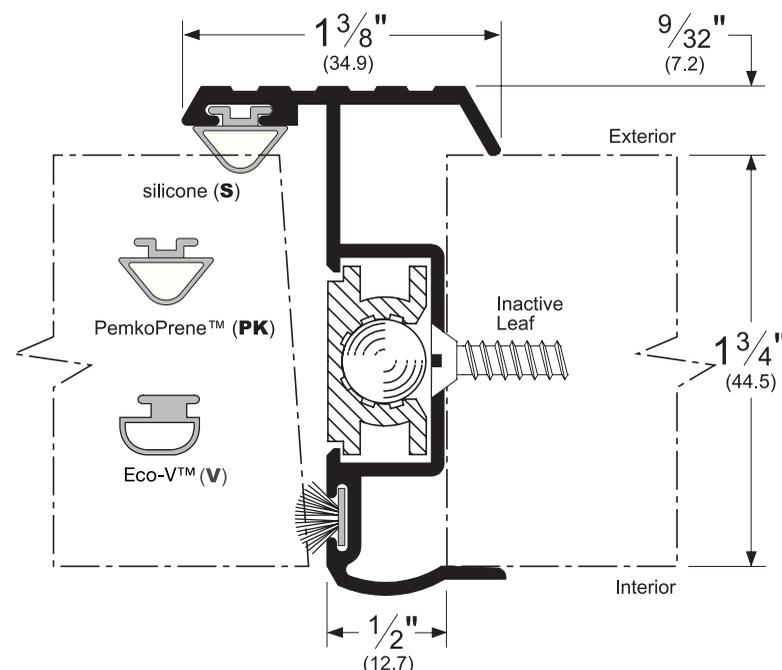

AVAILABLE FINISHES FOR PRODUCTS SHOWN ON THIS PAGE

C (Clear Anodized) **D** (Dark Bronze Anodized) **G** (Gold Anodized) **PW** (White)

800-824-3018 | www.pemko.com

Check the web site for the up-to-date catalog

Copyright © 2015-2024, ASSA ABLOY Accessories and Door Controls Group, Inc., an ASSA ABLOY Group company. All rights reserved.
Reproduction in whole or in part without the express written permission of ASSA ABLOY Accessories and Door Controls Group, Inc. is prohibited.

PEMKO
ASSA ABLOY

Experience a safer
and more open world

LOCKING ASTRAGALS

Colonial Style

Colonial style with slide bolt

3495_M

REPLACEMENT INSERT: **MAG349 (D, W)**

3495_Q

REPLACEMENT INSERT: **Q102 (D, W)**

AVAILABLE FINISHES: **C, D, PW**

• 3495 available with 18" aluminum bar; specify "L" at the end of product number (i.e. 3495_Q96L)

Colonial style with locking spring bolt

3496_M

REPLACEMENT INSERT: **MAG349 (D, W)**

3496_Q

REPLACEMENT INSERT: **Q102 (D, W)**

AVAILABLE FINISHES: **C, D, G, PW**

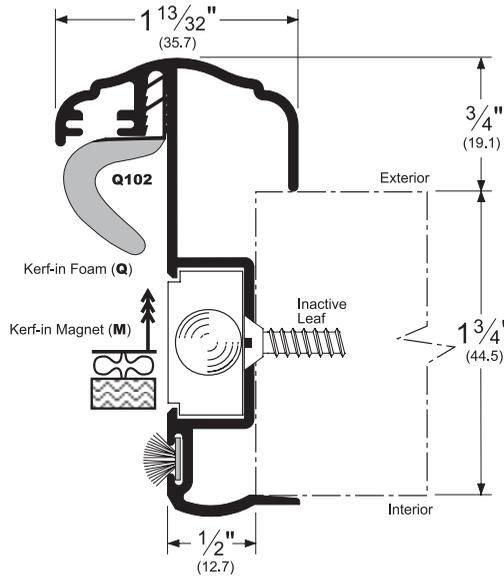

Q108_
 AVAILABLE FINISHES:
BL
 Available with Q108
 insert only upon
 request

AVAILABLE FINISHES FOR PRODUCTS SHOWN ON THIS PAGE
C (Clear Anodized) **D** (Dark Bronze Anodized) **G** (Gold Anodized)
PW (White) Kerf Colors: **BL** (Black) **D** (Dark Brown) **W** (White)



Experience a safer
and more open world

800-824-3018 | www.pemko.com
 Check the web site for the up-to-date catalog

Copyright © 2015-2024, ASSA ABLOY Accessories and Door Controls Group, Inc., an ASSA ABLOY Group company. All rights reserved.
 Reproduction in whole or in part without the express written permission of ASSA ABLOY Accessories and Door Controls Group, Inc. is prohibited.

OUTSWING LOCKING ASTRAGALS

- Weatherstripped astragals with locking spring bolts or slide bolts for 1³/₄" outswing double doors. Slide bolts are 18" from the top/bottom for easier access
- Odd numbered astragals have economical smooth acting slide bolts. Even numbered astragals have locking spring bolts. Both have full 3/8" diameter steel bolts with 1¹/₁₆" throw for improved locking strength. In the extended and locked position, locking spring bolts cannot be easily retracted by tampering. In the retracted position, the spring loaded bolts latch firmly, thus preventing marking of the floor and door header trim when opening or closing the inactive door
- All come with a Eco-V™ snap-in cover strip to conceal the cutout and to cover the mounting screws
- All feature four-way adjustable strike plate mounting for latchbolt and deadbolt
- All styles come with a molded sponge neoprene bottom seal
- Each astragal comes complete with an installation kit and detailed instructions
- Specify punchout locations with your order
- Specify handing using the handing chart below

Handing Chart For Astragals (For pages 169 thru 171)

- An astragal is handed by the hand of the active door. The hand of the active door is determined by the position of the hinges on the door, when viewed from the outside (the key side)

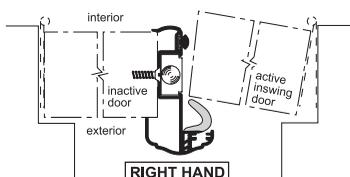
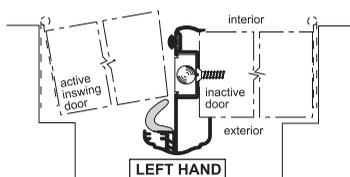

Slimline Style

Slimline style with slide bolt

3443_S

REPLACEMENT INSERT:

S4 (BL, GR)

AVAILABLE FINISHES:

C, D, WSP

3443 available with 18" aluminum bar; specify "L" at the end of product number (i.e. 3443_S96L)

Slimline style with locking spring bolt

3444_S

REPLACEMENT INSERT:

S4 (BL, GR)

AVAILABLE FINISHES:

C, D, WSP

Slimline Style

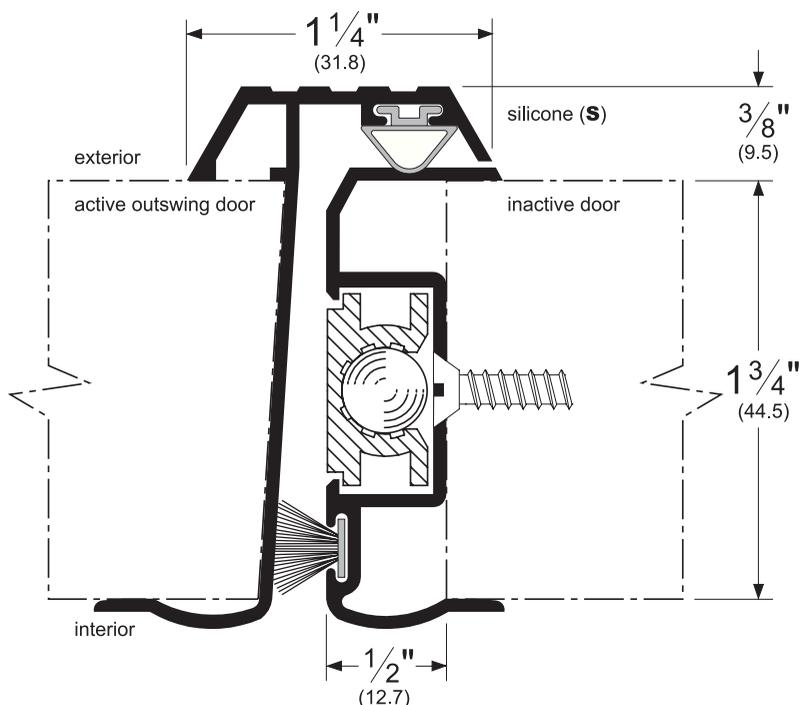

AVAILABLE FINISHES FOR PRODUCTS SHOWN ON THIS PAGE

C (Clear Anodized) **D** (Dark Bronze Anodized) **WSP** (White Suede Powder Coat)

800-824-3018 | www.pemko.com

Check the web site for the up-to-date catalog

Copyright © 2015-2024, ASSA ABLOY Accessories and Door Controls Group, Inc., an ASSA ABLOY Group company. All rights reserved. Reproduction in whole or in part without the express written permission of ASSA ABLOY Accessories and Door Controls Group, Inc. is prohibited.

PEMCO
ASSA ABLOY

Experience a safer
and more open world



Experience a safer
and more open world

800-824-3018 | www.pemko.com
Check the web site for the up-to-date catalog

Copyright © 2015-2024, ASSA ABLOY Accessories and Door Controls Group, Inc., an ASSA ABLOY Group company. All rights reserved.
Reproduction in whole or in part without the express written permission of ASSA ABLOY Accessories and Door Controls Group, Inc. is prohibited.

PEMKO BRUSH GASKETING



CONTENTS:

180° Aluminum Retainers	162
180° Concealed Fastener Retainers.....	163
90° Aluminum Retainers	164
45° Concealed Fastener Retainers.....	164
Mortise Retainers	166
Aluminum Retainer with Rain Drip	166
Oak Retainers	166
Meeting Stiles	167

NOTE: For Automatic Door Bottoms with Nylon Brush seals, please see Automatic Door Bottom catalog section.

INDEX:

PRODUCT	PAGE	PRODUCT	PAGE	PRODUCT	PAGE
345	166	18100.....	163	45061.....	165
3452.....	166	18100W.....	166	45062.....	165
5025.....	166	18137.....	162	45100.....	165
5041.....	166	18175.....	162	45137.....	165
5061.....	166	18250.....	162	45175.....	165
5100.....	166	18400.....	162	45250.....	165
18041.....	163	29324.....	163	45400.....	165
18041.....	167	29324.....	167	90041.....	164
18050.....	163	29326.....	163	90062.....	164
18061.....	163	29326.....	167	90100.....	164
18061.....	167	29344.....	164	90137.....	164
18062.....	163	29346.....	164	293100.....	163
18062W.....	166	45041.....	165		

NOTE: For Automatic Door Bottoms with Nylon Brush seals, please see Automatic Door Bottom catalog section.

180° ALUMINUM RETAINERS

- All brush seals consist of densely compressed nylon filaments encased in a high quality aluminum retainer. These products are ideally suited for hollow metal and wood door applications. Also use Pemko's brush weatherstripping product on overhead, section, sliding, and automatic doors
- All brush seals reduce the infiltration of light, air, wind, rain, and snow; prevent heat loss; and control the penetration of smoke and fumes
- Brush remains flexible down to -40°F and has a melting point above 400°F
- UV stable, dependable, long-lasting, cost-effective
- Punched with slotted holes for adjustment (except 35° angle types which are drilled with 1/8" hole)
- Naturally repels rodents and spiders; can be sprayed with household pest repellent for additional pest control

18137_NB

AVAILABLE FINISHES:
10BE, BSP, C, D, G, PW, WSP
 REPLACEMENT INSERT:
P38137 (BL, GR, W)
 ANSI: **R3A434**

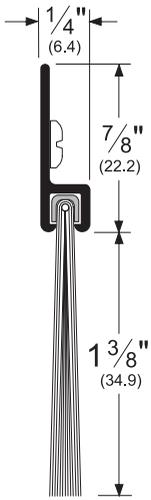

18175_NB

AVAILABLE FINISHES:
10BE, BSP, C, D, WSP
 REPLACEMENT INSERT:
P58175 (BL, GR)
 ANSI: **R3A434**

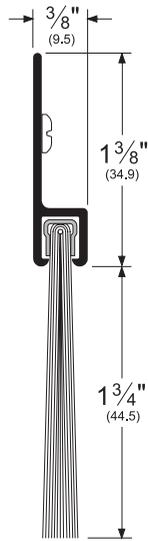

18250_NB

AVAILABLE FINISHES:
10BE, BSP, C, D, WSP
 REPLACEMENT INSERT:
P58250 (BL, GR)
 ANSI: **R3A434**

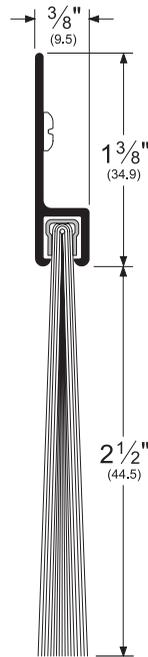

18400_NB

AVAILABLE FINISHES:
10BE, BSP, C, D, WSP
 REPLACEMENT INSERT:
P58400 (BL, GR)
 ANSI: **R3A434**

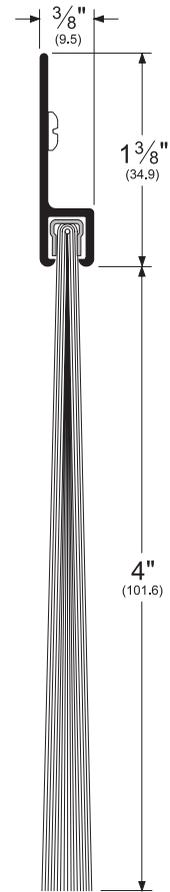

NOTE: Products shown in this section may not be drawn to scale.

AVAILABLE FINISHES FOR PRODUCTS SHOWN ON THIS PAGE

10BE (Satin Bronze Powder Coat) **BSP** (Black Suede Powder Coat) **C** (Clear Anodized)
D (Dark Bronze Anodized) **G** (Gold Anodized) **PW** (Painted White) **WSP** (White Suede Powder Coat)

800-824-3018 | www.pemko.com

Check the web site for the up-to-date catalog



Experience a safer
and more open world

180° ALUMINUM RETAINERS (Cont.)

18041_NB

AVAILABLE FINISHES:
10BE, BSP, C, D, G, PW, SN, WSP
 REPLACEMENT INSERT:
P516041 (BL, GR)
 ANSI: **R3A134, R3A164, R3A734**

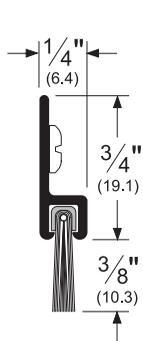

18050_NB

AVAILABLE FINISHES:
10BE, BSP, C, D, G, PW, SN, WSP
 REPLACEMENT INSERT:
P516050 (BL, GR)
 ANSI: **R3A434, R3A734**

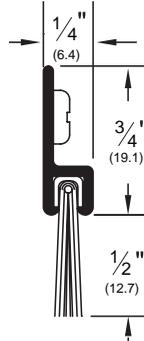

18061_NB

AVAILABLE FINISHES:
10BE, BSP, C, D, G, PW, SN, WSP
 REPLACEMENT INSERT:
P516062 (BL, GR, W)
 ANSI: **R3A434, R3A734**

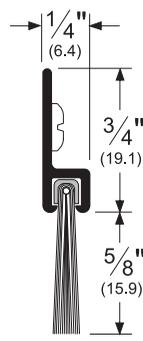

18062_NB

AVAILABLE FINISHES:
10BE, BSP, C, D, G, PW, WSP
 REPLACEMENT INSERT:
P38062 (BL, GR, W)
 ANSI: **R3A434**

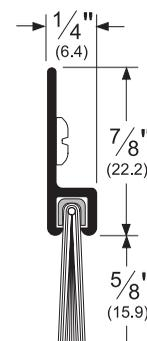

18100_NB

AVAILABLE FINISHES:
10BE, BSP, C, D, G, PW, WSP
 REPLACEMENT INSERT:
P38100 (BL, GR)
 ANSI: **R3A434**

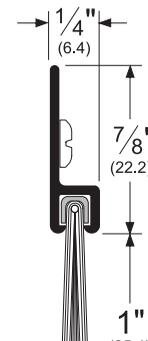

Alternate Inserts For 18041

18041_SB

AVAILABLE FINISHES: **10BE, BSP, C, D, G, PW, SN, WSP**
 REPLACEMENT INSERT: **P3 (BL, GR)**



180° CONCEALED FASTENER RETAINERS

- Aluminum snap cover conceals mounting screws to provide a clean aesthetic appearance
- Replacement snap cover is item _29316; when ordering, identify finish and length
- Cover snaps securely into place to deter vandalism

293100_NB

AVAILABLE FINISHES:
10BE, BSP, C, D, WSP
 REPLACEMENT INSERT:
P516100 (BL, GR, W)
 ANSI: **R3A434**

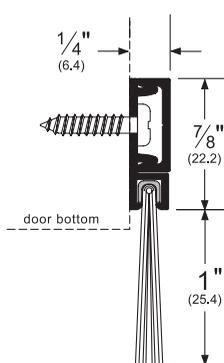

29326_NB

AVAILABLE FINISHES:
10BE, BSP, C, D, G, WSP
 REPLACEMENT INSERT:
P516062 (BL, GR, W)
 ANSI: **R3A434**

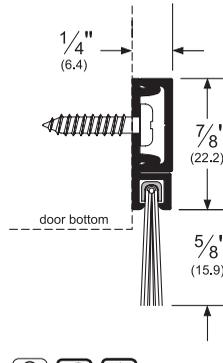

29324_NB

AVAILABLE FINISHES:
10BE, BSP, C, D, G, WSP
 REPLACEMENT INSERT:
P516041 (BL, GR)
 ANSI: **R3A434**

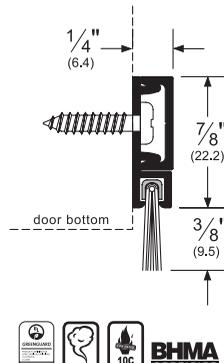

Alternate Insert For 29324

29324_SB

AVAILABLE FINISHES: **10BE, BSP, C, D, WSP**
 REPLACEMENT INSERT: **P3 (BL, GR)**



NOTE: Products shown in this section may not be drawn to scale.

AVAILABLE FINISHES FOR PRODUCTS SHOWN ON THIS PAGE

10BE (Satin Bronze Powder Coat) **BSP** (Black Suede Powder Coat) **C** (Clear Anodized)
D (Dark Bronze Anodized) **G** (Gold Anodized) **PW** (Painted White) **SN** (Satin Nickel Anodized)
WSP (White Suede Powder Coat)

800-824-3018 | www.pemko.com

Check the web site for the up-to-date catalog

Copyright © 2015-2024, ASSA ABLOY Accessories and Door Controls Group, Inc., an ASSA ABLOY Group company. All rights reserved.
 Reproduction in whole or in part without the express written permission of ASSA ABLOY Accessories and Door Controls Group, Inc. is prohibited.

PEMKO
ASSA ABLOY

Experience a safer
 and more open world

90° ALUMINUM RETAINERS

- Design permits use as a concealed seal for many applications
- Slotted holes for easy adjustment

90041_NB
 AVAILABLE FINISHES: **10BE, BSP, C, D, WSP**
 REPLACEMENT INSERT: **P516041 (BL, GR, W)**
 ANSI: **R3A164, R3A414**

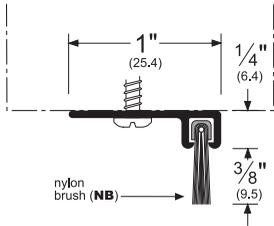

90062_NB
 AVAILABLE FINISHES: **10BE, BSP, C, D, WSP**
 REPLACEMENT INSERT: **P516062 (BL, GR, W)**
 ANSI: **R3A164, R3A414**

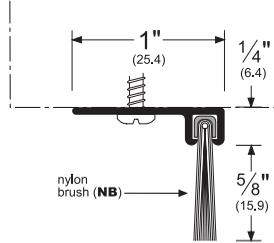

90100_NB
 AVAILABLE FINISHES: **10BE, BSP, C, D, WSP**
 REPLACEMENT INSERT: **P516100 (BL, GR, W)**
 ANSI: **R3A414**

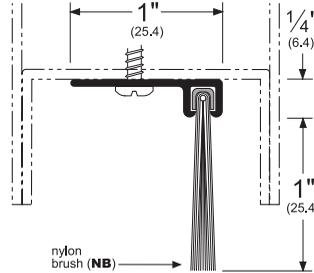

90137_NB
 AVAILABLE FINISHES: **10BE, BSP, C, D, WSP**
 REPLACEMENT INSERT: **P516137 (BL, GR, W)**
 ANSI: **R3A414**

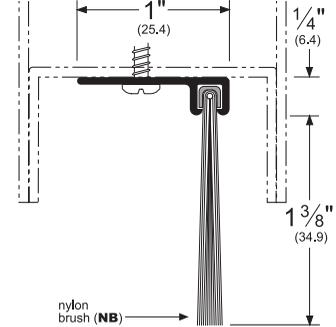

Alternate Insert For 90041

90041_SB

AVAILABLE FINISHES: **10BE, BSP, C, D, WSP**
 REPLACEMENT INSERT: **P3 (BL, GR)**



45° CONCEALED FASTENER RETAINERS

- Replacement snap cover is item _29316-
- When ordering, identify finish and length

29344_NB
 AVAILABLE FINISHES: **10BE, BSP, C, D, WSP**
 REPLACEMENT INSERT: **P516041 (BL, GR)**
 ANSI: **R3A164**

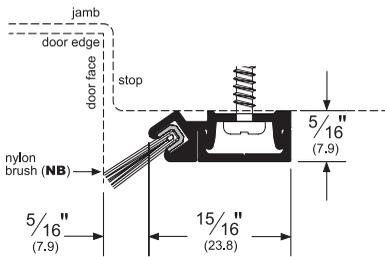

29346_NB
 AVAILABLE FINISHES: **10BE, BSP, C, D, WSP**
 REPLACEMENT INSERT: **P516062 (BL, GR, W)**
 ANSI: **R3A164**

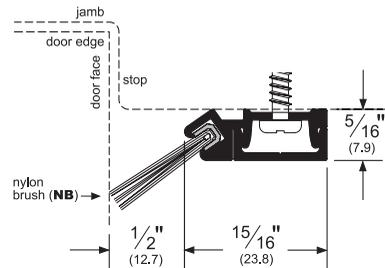

Alternate Insert For 29344

29344_SB

AVAILABLE FINISHES: **10BE, BSP, C, D, WSP**
 REPLACEMENT INSERT: **P3 (BL, GR)**



NOTE: Products shown in this section may not be drawn to scale.

AVAILABLE FINISHES FOR PRODUCTS SHOWN ON THIS PAGE

10BE (Satin Bronze Powder Coat) **BSP** (Black Suede Powder Coat) **C** (Clear Anodized)
D (Dark Bronze Anodized) **WSP** (White Suede Powder Coat)

PEMKO
ASSA ABLOY

Experience a safer
 and more open world

800-824-3018 | www.pemko.com
 Check the web site for the up-to-date catalog

Copyright © 2015-2024, ASSA ABLOY Accessories and Door Controls Group, Inc., an ASSA ABLOY Group company. All rights reserved.
 Reproduction in whole or in part without the express written permission of ASSA ABLOY Accessories and Door Controls Group, Inc. is prohibited.

45° ALUMINUM RETAINERS

- Slotted holes for easy adjustment

45061_NB
 AVAILABLE FINISHES:
10BE, BSP, C, D, WSP
 REPLACEMENT INSERT:
P516062 (BL, GR, W)
 ANSI: **R3A164**

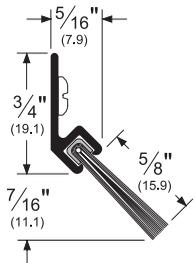

45062_NB
 AVAILABLE FINISHES:
10BE, BSP, C, D, WSP
 REPLACEMENT INSERT:
P38062 (BL, GR, W)
 ANSI: **R3A164**

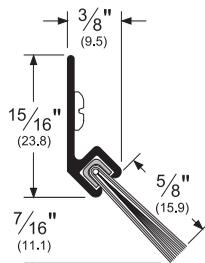

45100_NB
 AVAILABLE FINISHES:
10BE, BSP, C, D, WSP
 REPLACEMENT INSERT:
P38100 (BL, GR)
 ANSI: **R3A164**

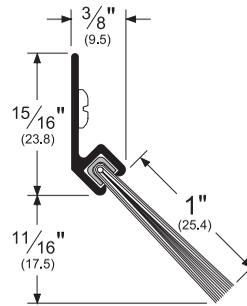

45137_NB
 AVAILABLE FINISHES:
10BE, BSP, C, D, WSP
 REPLACEMENT INSERT:
P58137 (BL, GR, W)
 ANSI: **R3A164**

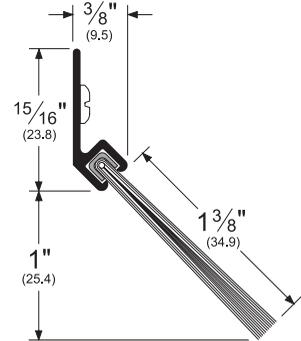

45041_NB
 AVAILABLE FINISHES:
10BE, BSP, C, D, WSP
 REPLACEMENT INSERT:
P516041 (BL, GR)
 ANSI: **R3A164**

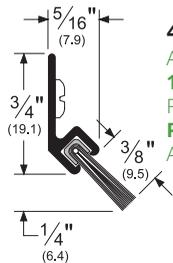

Alternate Insert For 45041

45041_SB
 AVAILABLE FINISHES:
10BE, BSP, C, D, WSP
 REPLACEMENT INSERT: **P3 (BL, GR)**



soft brush (SB)

45175_NB
 AVAILABLE FINISHES:
10BE, BSP, C, D, WSP
 REPLACEMENT INSERT:
P58175 (BL, GR)
 ANSI: **R3A164**

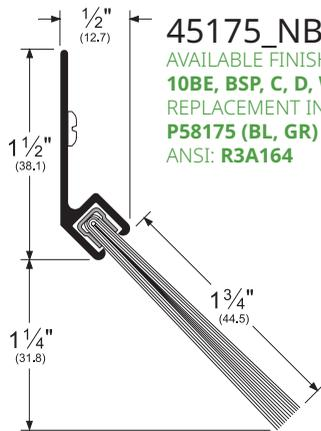

45250_NB
 AVAILABLE FINISHES:
10BE, BSP, C, D, WSP
 REPLACEMENT INSERT:
P58250 (BL, GR)
 ANSI: **R3A164**

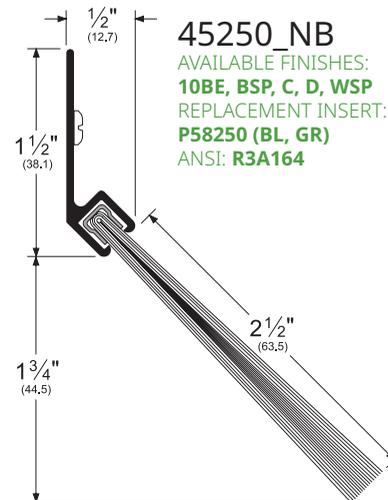

45400_NB
 AVAILABLE FINISHES:
10BE, BSP, C, D, WSP
 REPLACEMENT INSERT:
P58400 (BL, GR)
 ANSI: **R3A164**

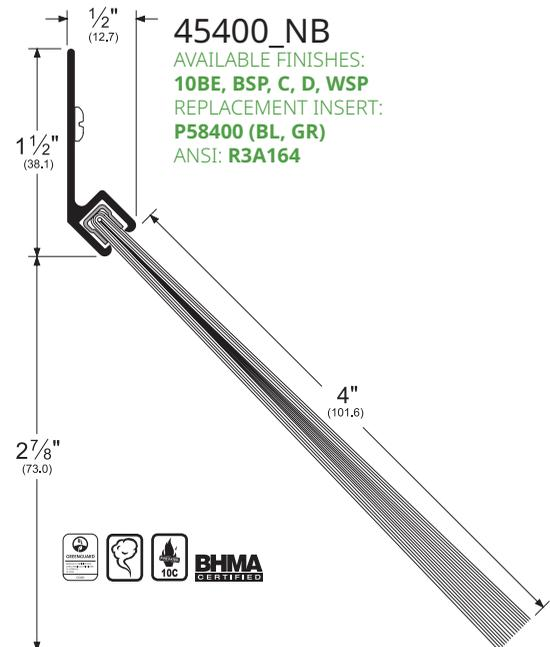

NOTE: Products shown in this section may not be drawn to scale.

AVAILABLE FINISHES FOR PRODUCTS SHOWN ON THIS PAGE
10BE (Satin Bronze Powder Coat) **BSP** (Black Suede Powder Coat) **C** (Clear Anodized)
D (Dark Bronze Anodized) **WSP** (White Suede Powder Coat)

800-824-3018 | www.pemko.com

Check the web site for the up-to-date catalog

Copyright © 2015-2024, ASSA ABLOY Accessories and Door Controls Group, Inc., an ASSA ABLOY Group company. All rights reserved.
 Reproduction in whole or in part without the express written permission of ASSA ABLOY Accessories and Door Controls Group, Inc. is prohibited.

PEMKO
ASSA ABLOY

Experience a safer
 and more open world

MORTISE RETAINERS

- The ultimate design for concealed weatherstrip needs
- Can be used on doors, windows and more

5025_NB

AVAILABLE FINISH: **A**
REPLACEMENT INSERT:
P14025 (BL, GR)

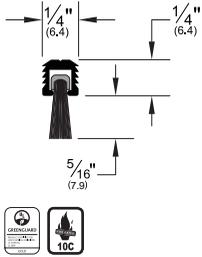

5041_NB

AVAILABLE FINISH: **A**
REPLACEMENT INSERT:
P516041 (BL, GR)

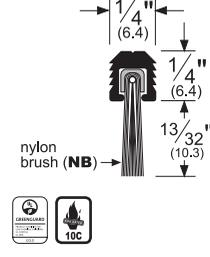

5061_NB

AVAILABLE FINISH: **A**
REPLACEMENT INSERT:
P516062 (BL, GR, W)

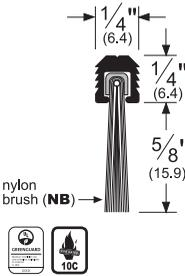

5100_NB

AVAILABLE FINISH: **A**
REPLACEMENT INSERT:
P516100 (BL, GR, W)

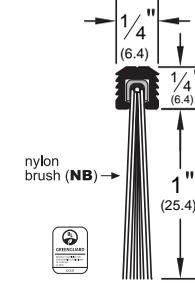

Alternate Insert For
5025 and 5041

5025_SB

AVAILABLE FINISHES: **A**
REPLACEMENT INSERT:
SB14025 (BL, GR)



5041_SB

AVAILABLE FINISHES: **A**
REPLACEMENT INSERT:
P3 (BL, GR)

ALUMINUM RETAINER WITH RAIN DRIP

- Slotted holes for easy adjustment

345_NB

AVAILABLE FINISHES:
10BE, A, BSP, D, G, WSP
REPLACEMENT INSERT:
P14100 (BL, GR)
ANSI: **R3A534**

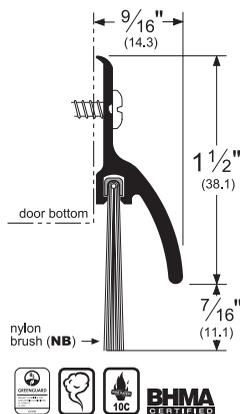

3452_NB

AVAILABLE FINISHES:
10BE, A, BSP, D, G, WSP
REPLACEMENT INSERT:
P14075 (BL, GR)
ANSI: **R3A534**

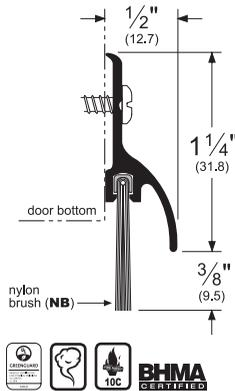

OAK RETAINERS 36" WIDE

- These products have 1/8" drilled fastener holes

18062WNB

AVAILABLE FINISH: **W**
REPLACEMENT INSERT:
P516062 (BL, GR, W)

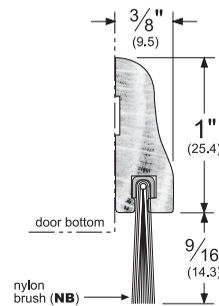

18100WNB

AVAILABLE FINISH: **W**
REPLACEMENT INSERT:
P516100 (BL, GR)

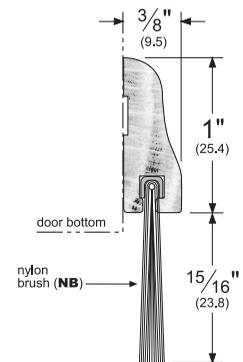

NOTE: Products shown in this section may not be drawn to scale.

AVAILABLE FINISHES FOR PRODUCTS SHOWN ON THIS PAGE

10BE (Satin Bronze Powder Coat) **A** (Mill Finish Aluminum) **BSP** (Black Suede Powder Coat) **C** (Clear Anodized)
D (Dark Bronze Anodized) **G** (Gold Anodized) **W** (Unfinished Solid Oak) **WSP** (White Suede Powder Coat)

PEMKO
ASSA ABLOY

Experience a safer
and more open world

800-824-3018 | www.pemko.com
Check the web site for the up-to-date catalog

Copyright © 2015-2024, ASSA ABLOY Accessories and Door Controls Group, Inc., an ASSA ABLOY Group company. All rights reserved.
Reproduction in whole or in part without the express written permission of ASSA ABLOY Accessories and Door Controls Group, Inc. is prohibited.

MEETING STILES

- Astragals and Meeting Stiles with a fire label may be mounted on pairs of doors wherein the gap meets the requirements of NFPA 80-2013, 6.3.1.7.1 **“The clearance between... the meeting edges of doors swinging in pairs on the pull side shall be 1/8" ± 1/16" (3.18mm ± 1.59mm) for steel doors and shall not exceed 1/8" (3.18mm) for wood doors”**

- Snap cover helps prevent vandalism and adds an attractive finished look by concealing the fasteners
- Replacement snap cover is item _29316. When ordering, identify finish and length
- NOTE: Although drawn with a gap between the brush, when installed, these brush products SHOULD make contact. Brush should mesh from 1/32" to 1/16"

18041_NB

AVAILABLE FINISHES: **10BE, BSP, C, D, G, SN, WSP**
 REPLACEMENT INSERT: **P516041 (BL, GR)**
 ANSI: **R3A734**

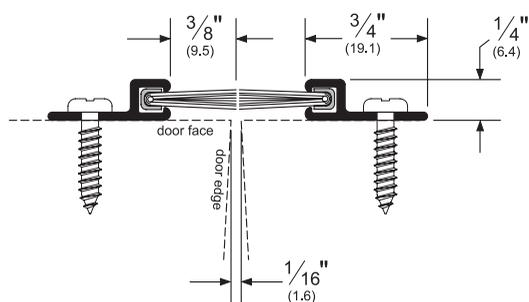

Alternate Insert For 18041

18041_SB

AVAILABLE FINISHES:
10BE, BSP, C, D, G, SN, WSP
 REPLACEMENT INSERT: **P3 (BL, GR)**



soft brush (SB)

29324_NB

AVAILABLE FINISHES: **10BE, BSP, C, D, G, SN, WSP**
 REPLACEMENT INSERT: **P516041 (BL, GR)**
 ANSI: **R3A434, R3A435**

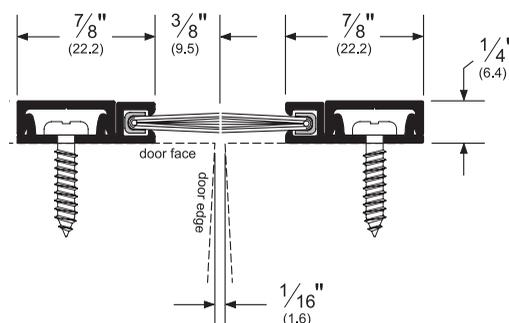

Alternate Insert For 29324

29324_SB

AVAILABLE FINISHES:
10BE, BSP, C, D, G, SN, WSP
 REPLACEMENT INSERT: **P3 (BL, GR)**



soft brush (SB)

18061_NB

AVAILABLE FINISHES: **10BE, BSP, C, D, G, SN, WSP**
 REPLACEMENT INSERT: **P516062 (BL, GR, W)**
 ANSI: **R3A734**

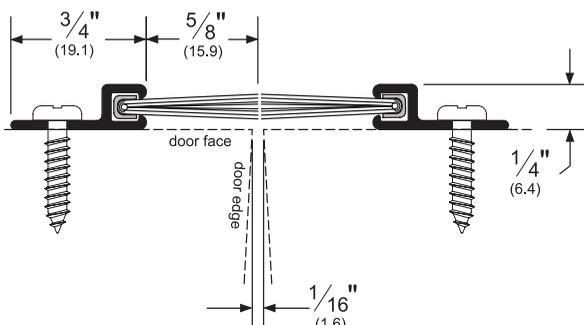

29326_NB

AVAILABLE FINISHES: **10BE, BSP, C, D, G, SN, WSP**
 REPLACEMENT INSERT: **P516062 (BL, GR, W)**
 ANSI: **R3A764, R3A765**

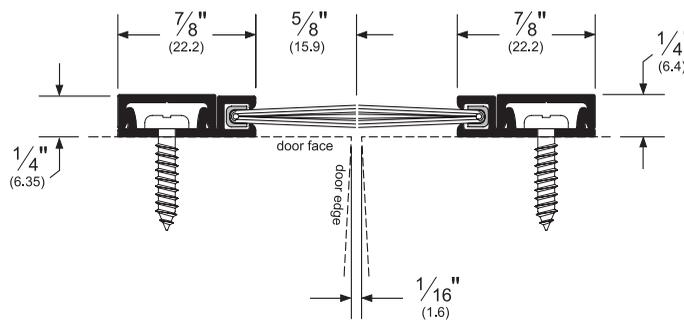

NOTE: Products shown in this section may not be drawn to scale.

AVAILABLE FINISHES FOR PRODUCTS SHOWN ON THIS PAGE

10BE (Satin Bronze Powder Coat) **BSP** (Black Suede Powder Coat) **C** (Clear Anodized)
D (Dark Bronze Anodized) **G** (Gold Anodized) **SN** (Satin Nickel Anodized) **WSP** (White Suede Powder Coat)

800-824-3018 | www.pemko.com

Check the web site for the up-to-date catalog

Copyright © 2015-2024, ASSA ABLOY Accessories and Door Controls Group, Inc., an ASSA ABLOY Group company. All rights reserved.
 Reproduction in whole or in part without the express written permission of ASSA ABLOY Accessories and Door Controls Group, Inc. is prohibited.

PEMKO
ASSA ABLOY

Experience a safer
 and more open world



Experience a safer
and more open world

800-824-3018 | www.pemko.com
Check the web site for the up-to-date catalog

Copyright © 2015-2024, ASSA ABLOY Accessories and Door Controls Group, Inc., an ASSA ABLOY Group company. All rights reserved.
Reproduction in whole or in part without the express written permission of ASSA ABLOY Accessories and Door Controls Group, Inc. is prohibited.

PEMKO PERIMETER GASKETING

CONTENTS:

Standard Perimeter Gasketing	170
Perimeter Gasket Solutions for Sliding Doors.....	173
Stainless Steel Perimeter Gasketing.....	174
Adjustable Jamb Gasketing.....	175
Heavy Duty Interlock Perimeter Gasketing.....	175
Heavy Duty Perimeter Gasketing - Head Section	176
Heavy Duty Perimeter Gasketing - Standard Jamb.....	177
Perimeter Gasket Jamb Brackets.....	177
Snap Cover Perimeter Gasketing With Concealed Fasteners.....	178
Kerf-In Weatherstrip.....	179
Magnetic Weatherstrip	180
Adhesive Perimeter Gasketing.....	180
MicroShield® Antimicrobial Adhesive Gasketing.....	181
Excessive Gap Perimeter Solution.....	182
Interlock Weatherstrip For Wood Windows.....	182
Interlock Weatherstrip For Wood Doors.....	183
Cushion/Spring Weatherstrip.....	183
Fasteners for Cushion, Spring and Interlock Weatherstrip.....	183
Privacy Seals for Sliding Doors.....	184

INDEX:

PRODUCT	PAGE	PRODUCT	PAGE	PRODUCT	PAGE
2P.....	182	331	183	MAG349	180
4C	182	332	171	NL1678	183
4P.....	182	335	175	NL1734CPXE_.....	183
10.....	182	336	175	NL13516	183
30.....	183	350	175	P50	180
41M.....	183	375.....	171	P51B17.....	183
43.....	183	379	175	PEMKOSFSET	184
70C-100	183	394	173	PK33.....	181
70D-100	183	394	184	PK52.....	180
70E-99	183	950	173	PK55.....	181
73.....	183	950	184	PY900	173
74.....	183	2815_M.....	180	Q102.....	179
75.....	183	2891	176	Q103.....	179
285	172	2892	176	Q106	179
290	177	2893.....	176	Q107.....	179
294	173	2902.....	177	Q108	179
296	172	2903.....	177	S44	180
297.....	170	3151.....	172	S52.....	179
303	170	29310.....	178	S77	181
305	171	29313.....	178	S88	180
305SS.....	174	29326.....	178	S104	179
306	173	29344	178	S105	179
309	173	29346	178	S109	179
312.....	172	29394.....	173	S442.....	181
315.....	172	29394.....	184	S771x6.....	181
315SS.....	174	AM88	181	S773.....	180
316.....	170	BKT050.....	177	S776	181
319.....	171	BKT075.....	177	XG90KIT	182
319SS.....	174	BKT1532.....	177	XG900.....	182
322	175	EZGAP™ XG10.....	182		
330	172	HSS20XGxS773.....	182		



800-824-3018 | www.pemko.com

Check the web site for the up-to-date catalog

Copyright © 2015-2024, ASSA ABLOY Accessories and Door Controls Group, Inc., an ASSA ABLOY Group company. All rights reserved.
 Reproduction in whole or in part without the express written permission of ASSA ABLOY Accessories and Door Controls Group, Inc. is prohibited.



Experience a safer
and more open world

STANDARD PERIMETER GASKETING

- Rigid jamb weatherstrip shown mounted on openings with 1/16" gaps; however, each weatherstrip can seal gaps up to the depth of its seal. Seal depth provided on each illustration (example: the 303 has a 1/4" seal; therefore, it can seal up to a 1/4" gap)
- Punched on 6" centers with slotted holes for adjustment. Models 294, 303, and 306 are available with self-adhesive two-sided tape (TST) and tek screws (3 slotted holes per part) for easy installation. To obtain this option, add "TST" to the end of the part when ordering (example: 303AVTST)

303_S

AVAILABLE FINISHES:
10BE, A, BSP, C, D, G, PW, SN, WSP
 REPLACEMENT INSERT: **S3 (BL, W)**
 ANSI: **R3E164, R3E165**

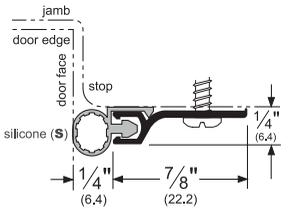

303_PK

AVAILABLE FINISHES:
10BE, A, BSP, C, D, G, PW, SN, WSP
 REPLACEMENT INSERT: **PK47 (BL, GR)**
 ANSI: **R3G164**

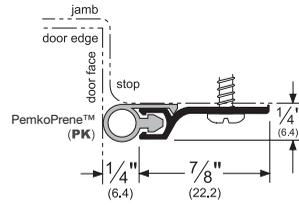

303_V

AVAILABLE FINISHES:
10BE, A, BSP, C, D, G, PW, SN, WSP
 REPLACEMENT INSERT: **EV47 (BL, GR, W)**

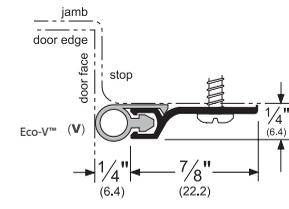

316_S

AVAILABLE FINISHES:
10BE, A, BDG, BSP, D, G, WSP
 REPLACEMENT INSERT: **S3 (BL, W)**
 ANSI: **R3E164, R3E165**

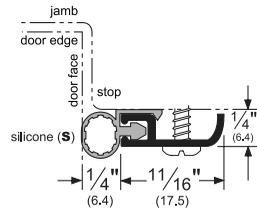

316_PK

AVAILABLE FINISHES:
10BE, A, BDG, BSP, D, G, WSP
 REPLACEMENT INSERT: **PK47 (BL, GR)**
 ANSI: **R3G164, R3G165**

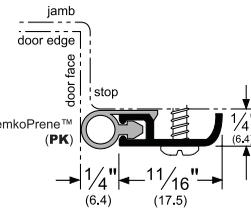

316_V

AVAILABLE FINISHES:
10BE, A, BDG, BSP, D, G, WSP
 REPLACEMENT INSERT: **EV47 (BL, GR, W)**

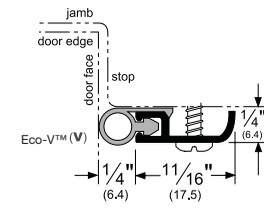

297_S

AVAILABLE FINISHES:
10BE, A, BDG, BSP, D, PW, SN, WSP
 REPLACEMENT INSERT: **S3 (BL, W)**
 ANSI: **R3E164, R3E165**

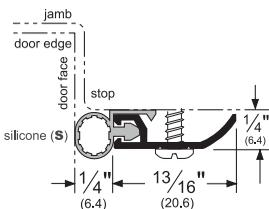

297_PK

AVAILABLE FINISHES:
10BE, A, BDG, BSP, D, PW, SN, WSP
 REPLACEMENT INSERT: **PK47 (BL, GR)**
 ANSI: **R3G164, R3G165**

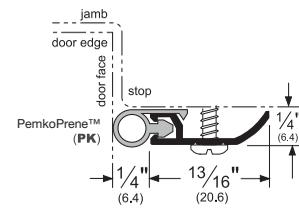

297_V

AVAILABLE FINISHES:
10BE, A, BDG, BSP, D, PW, SN, WSP
 REPLACEMENT INSERT: **EV47 (BL, GR, W)**

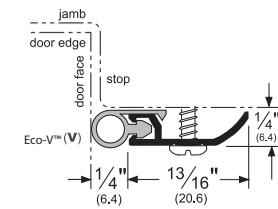

NOTE: Products shown in this section may not be drawn to scale.

AVAILABLE FINISHES FOR PRODUCTS SHOWN ON THIS PAGE

- 10BE** (Satin Bronze Powder Coat) **A** (Mill Finish Aluminum) **BDG** (Bright Dip Gold Anodized)
- BSP** (Black Suede Powder Coat) **C** (Clear Anodized) **D** (Dark Bronze Anodized) **G** (Gold Anodized)
- PW** (Painted White) **SN** (Satin Nickel Anodized) **WSP** (White Suede Powder Coat)



Experience a safer and more open world

800-824-3018 | www.pemko.com
 Check the web site for the up-to-date catalog

Copyright © 2015-2024, ASSA ABLOY Accessories and Door Controls Group, Inc., an ASSA ABLOY Group company. All rights reserved. Reproduction in whole or in part without the express written permission of ASSA ABLOY Accessories and Door Controls Group, Inc. is prohibited.

STANDARD PERIMETER GASKETING (Cont.)

305_N

AVAILABLE FINISHES:
10BE, B, BSP, C, D, WSP
 REPLACEMENT INSERT: **E2 (BL)**
 ANSI (alum): **R3G164, R3G165**
 ANSI (brass): **R1G164, R1G165**

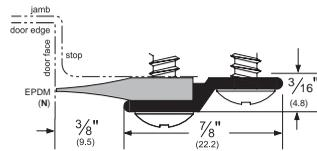

305_R

AVAILABLE FINISHES:
10BE, B, BSP, C, D, G, WSP
 REPLACEMENT INSERT: **ER1 (BL)**
 ANSI (alum): **R3G164, R3G165**
 ANSI (brass): **R1G164, R1G165**

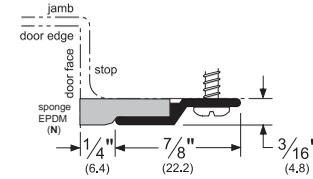

305_S

AVAILABLE FINISHES:
10BE, B, BSP, C, D, G, WSP
 REPLACEMENT INSERT: **SR1 (BL)**
 ANSI: **R3E164, R3E165**

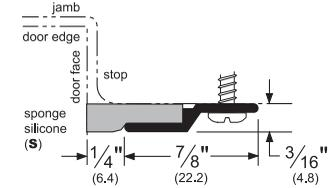

319_N

AVAILABLE FINISHES: **10BE, BSP, C, D, G, WSP**
 REPLACEMENT INSERT: **E11 (BL)**
 ANSI: **R3G164, R3G165**

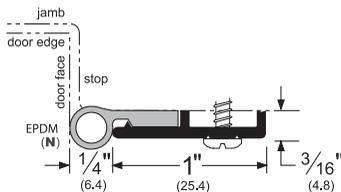

319_R

AVAILABLE FINISHES: **10BE, BSP, C, D, G, WSP**
 REPLACEMENT INSERT: **ER1 (BL)**
 ANSI: **R3G164, R3G165**

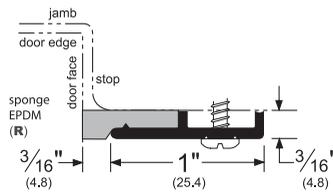

319_S

AVAILABLE FINISHES: **10BE, BSP, C, D, G, WSP**
 REPLACEMENT INSERT: **SR1 (BL)**
 ANSI: **R3E165**

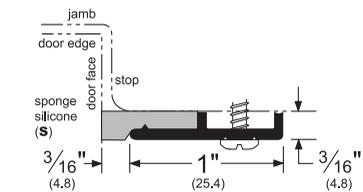

375_R

AVAILABLE FINISHES:
10BE, BSP, C, D, G, WSP
 REPLACEMENT INSERT: **ER6 (BL)**
 ANSI (alum): **R3C164, R3C165**

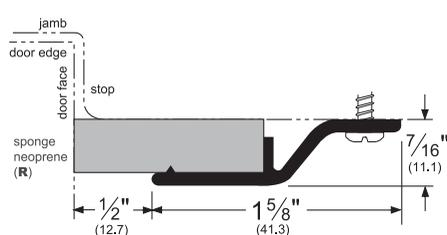

332_R

AVAILABLE FINISHES:
10BE, BSP, C, D, WSP
 REPLACEMENT INSERT: **ER1 (BL)**
 ANSI: **R3G164, R3G165**

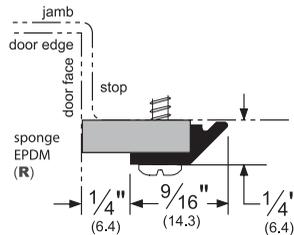

332_S

AVAILABLE FINISHES:
10BE, BSP, C, D, WSP
 REPLACEMENT INSERT: **SR1 (BL)**
 ANSI: **R3E164, R3E165**

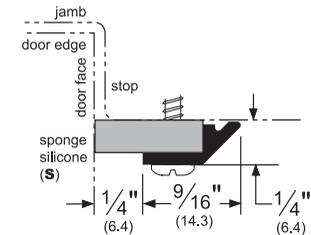

NOTE: Products shown in this section may not be drawn to scale.

AVAILABLE FINISHES FOR PRODUCTS SHOWN ON THIS PAGE

10BE (Satin Bronze Powder Coat) **A** (Mill Finish Aluminum) **B** (Mill Finish Extruded Bronze [Brass])
BDG (Bright Dip Gold Anodized) **BSP** (Black Suede Powder Coat) **C** (Clear Anodized)
D (Dark Bronze Anodized) **G** (Gold Anodized) **WSP** (White Suede Powder Coat)

800-824-3018 | www.pemko.com

Check the web site for the up-to-date catalog

Copyright © 2015-2024, ASSA ABLOY Accessories and Door Controls Group, Inc., an ASSA ABLOY Group company. All rights reserved.
 Reproduction in whole or in part without the express written permission of ASSA ABLOY Accessories and Door Controls Group, Inc. is prohibited.



Experience a safer
and more open world

STANDARD PERIMETER GASKETING (Cont.)

312_R

AVAILABLE FINISHES:
10BE, BSP, C, D, G, WSP
 REPLACEMENT INSERT: **ER9BL (BL)**
 ANSI (alum): **R3G164, R3G165**

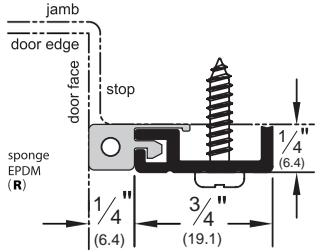

315_R

AVAILABLE FINISHES:
10BE, B, BSP, C, D, WSP
 REPLACEMENT INSERT: **ER9BL (BL)**
 ANSI (alum): **R3G164, R3G165**

• Please consult website for correct 315BR profile.

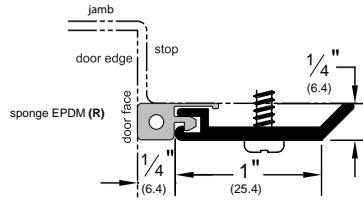

3151_R

AVAILABLE FINISHES:
10BE, BSP, C, D, G, WSP
 REPLACEMENT INSERT: **ER2 (BL)**
 ANSI (alum): **R3G164**

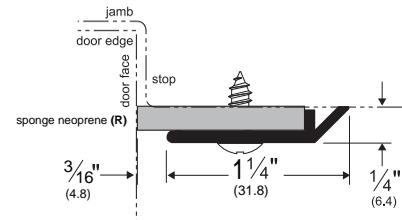

296_S

AVAILABLE FINISHES:
10BE, BSP, C, D, WSP
 REPLACEMENT INSERT: **SR6 (BL)**
 ANSI (alum): **R3E164, R3E165**

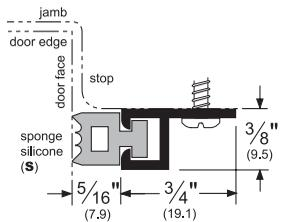

296_PK

AVAILABLE FINISHES:
10BE, BSP, C, D, WSP
 REPLACEMENT INSERT: **PK4132 (BL)**
 ANSI (alum): **R3G164, R3G165**

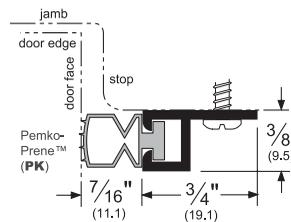

296_R

AVAILABLE FINISHES:
10BE, BSP, C, D, WSP
 REPLACEMENT INSERT: **E7 (BL)**
 ANSI (alum): **R3G164, R3G165**

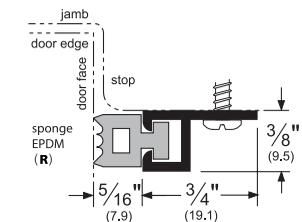

330_V

AVAILABLE FINISHES:
10BE, A, BSP, D, SN, WSP
 REPLACEMENT INSERT: **EV61 (BL, GR)**

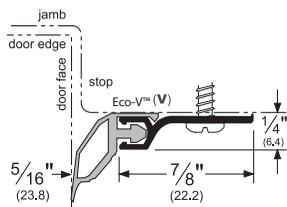

285_PK

AVAILABLE FINISHES:
10BE, BSP, C, D, G, WSP
 REPLACEMENT INSERT: **PK4304 (BL)**
 ANSI (alum): **R3G164, R3G165**

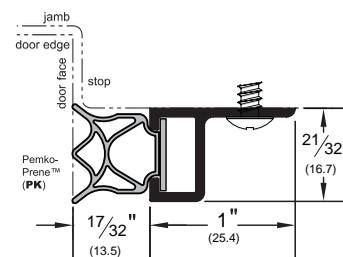

285_R

AVAILABLE FINISHES:
10BE, BSP, C, D, G, WSP
 REPLACEMENT INSERT: **E4303 (BL)**
 ANSI (alum): **R3G166**

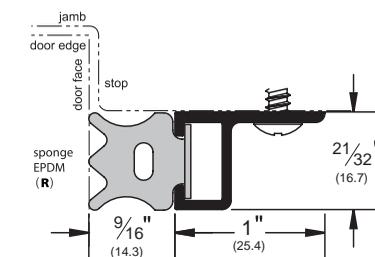

NOTE: Products shown in this section may not be drawn to scale.

AVAILABLE FINISHES FOR PRODUCTS SHOWN ON THIS PAGE

- 10BE** (Satin Bronze Powder Coated Aluminum) **A** (Mill Finish Aluminum) **B** (Mill Finish Extruded Bronze [Brass])
- BSP** (Black Suede Powder Coated Aluminum) **C** (Clear Anodized) **D** (Dark Bronze Anodized)
- G** (Gold Anodized) **SN** (Satin Nickel Anodized) **WSP** (White Suede Powder Coated Aluminum)



Experience a safer
and more open world

800-824-3018 | www.pemko.com
 Check the web site for the up-to-date catalog

Copyright © 2015-2024, ASSA ABLOY Accessories and Door Controls Group, Inc., an ASSA ABLOY Group company. All rights reserved.
 Reproduction in whole or in part without the express written permission of ASSA ABLOY Accessories and Door Controls Group, Inc. is prohibited.

STANDARD PERIMETER GASKETING (Cont.)

306_Q

AVAILABLE FINISHES: **10BE, A, BSP, D, WSP**
 REPLACEMENT INSERT: **Q103 (D, W)**

- Minimum space between the door face and the stop is $\frac{3}{16}$ " ; maximum space is $\frac{5}{16}$ "
- Note insert color when ordering: Dark Brown (D) or White (W)

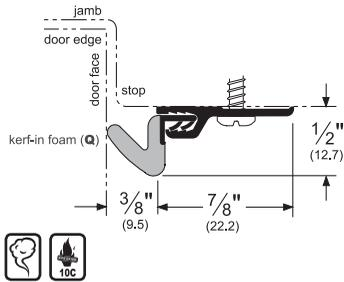

306_V

AVAILABLE FINISHES: **10BE, A, BSP, D, WSP**
 REPLACEMENT INSERT: **EV59 (BL, GR)**

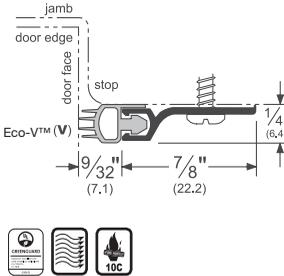

309_P

AVAILABLE FINISHES: **10BE, A, BSP, D, WSP**
 REPLACEMENT INSERT: **P3 (BL, GR)**

- Minimum space between the door face and the stop is $\frac{3}{16}$ " ; maximum space is $\frac{5}{16}$ "
- May also be used as a door bottom sweep

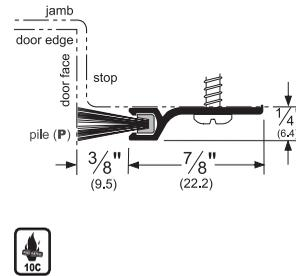

294_V

AVAILABLE FINISHES: **10BE, A, BSP, D, PW, SN, WSP**
 REPLACEMENT INSERT: **EV60 (GR)**

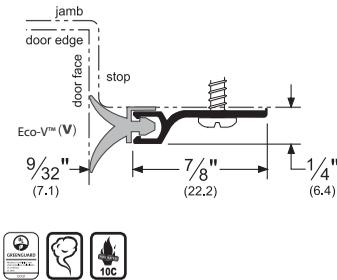

PERIMETER GASKET SOLUTIONS FOR SLIDING DOORS

- For Seal Set information, please see sets outlined on page 202

29394_PK

AVAILABLE FINISHES: **10BE, BSP, C, D, WSP**
 REPLACEMENT INSERT: **PK47 (GR, BL)**

- Perimeter sealing, used with 394 wall-mounted ramp

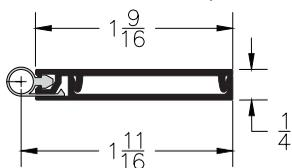

394_

AVAILABLE FINISHES: **10BE, BSP, C, D, WSP**

- Wall-mounted ramp used with 29394_PK

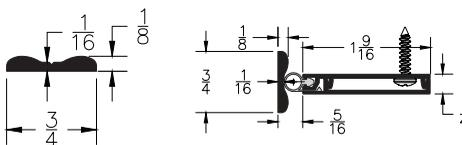

950_

AVAILABLE FINISHES: **10BE, BSP, C, D, WSP**
 REPLACEMENT INSERT: **PY900 (BL)**

- Head mounted sealing system

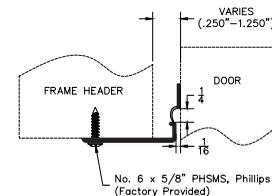

NOTE: Products shown in this section may not be drawn to scale.

AVAILABLE FINISHES FOR PRODUCTS SHOWN ON THIS PAGE

- 10BE** (Satin Bronze Powder Coated Aluminum) **A** (Mill Finish Aluminum)
- BSP** (Black Suede Powder Coated Aluminum) **C** (Clear Anodized) **D** (Dark Bronze Anodized)
- PW** (Painted White) **SN** (Satin Nickel Anodized) **WSP** (White Suede Powder Coated Aluminum)

800-824-3018 | www.pemko.com

Check the web site for the up-to-date catalog

Copyright © 2015-2024, ASSA ABLOY Accessories and Door Controls Group, Inc., an ASSA ABLOY Group company. All rights reserved. Reproduction in whole or in part without the express written permission of ASSA ABLOY Accessories and Door Controls Group, Inc. is prohibited.



Experience a safer and more open world

STAINLESS STEEL PERIMETER GASKETING

- Stainless Steel is a tough and durable material that tolerates exposure to chemicals and heavy use
- Easy to clean to meet sanitary requirements
- Manufactured from 430 Stainless Steel
- Long lasting with low cost of ownership

305SSE

AVAILABLE FINISH: **SS (#4 Finish)**
 REPLACEMENT INSERT: **E2 (BL)**
 ANSI: **R5G164, R5G165**

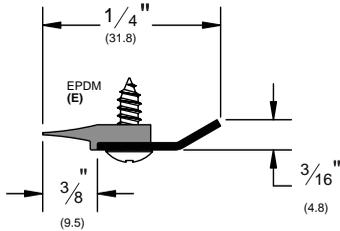

305SSR

AVAILABLE FINISH: **SS (#4 Finish)**
 REPLACEMENT INSERT: **ER1 (BL)**
 ANSI: **R5G164, R5G165**

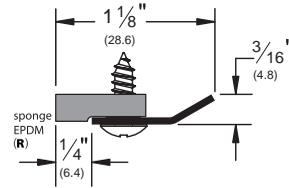

305SSS

AVAILABLE FINISH: **SS (#4 Finish)**
 REPLACEMENT INSERT: **SR1 (BL)**
 ANSI: **R5E164, R5E165**

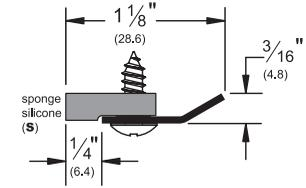

315SSR

AVAILABLE FINISH: **SS (#4 Finish)**
 REPLACEMENT INSERT: **ER2 (BL)**
 ANSI: **R5G164, R5G165**

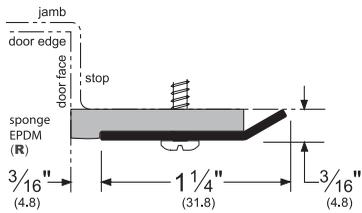

319SSN

AVAILABLE FINISH: **SS (#4 Finish)**
 REPLACEMENT INSERT: **E11 (BL)**
 ANSI: **R5G164, R5G165**

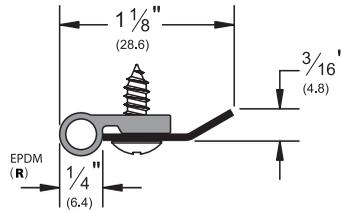

NOTE: Products shown in this section may not be drawn to scale.

AVAILABLE FINISHES FOR PRODUCTS SHOWN ON THIS PAGE
SS (See Individual Part)

PEMKO
ASSA ABLOY

Experience a safer
 and more open world

ADJUSTABLE JAMB GASKETING

• Adjustable jamb gasketing is shown mounted on openings with $\frac{1}{16}$ " gaps; however, each weatherstrip can seal gaps up to $\frac{1}{4}$ "

• Adjustable jamb weatherstrip can adjust $\frac{3}{16}$ " out from the position illustrated

379_S

AVAILABLE FINISHES: **10BE, BSP, C, D, G, WSP**
REPLACEMENT INSERT: **SR6 (BL)**
ANSI: **R3E264, R3E265**

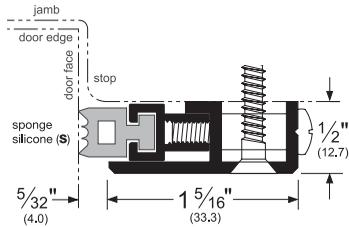

379_PK

AVAILABLE FINISHES: **10BE, BSP, C, D, G, WSP**
REPLACEMENT INSERT: **PK4132 (BL)**
ANSI: **R3G264, R3G265**

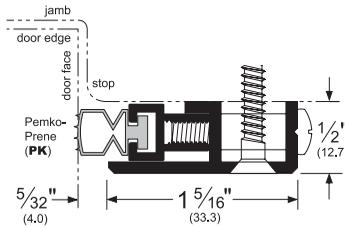

379_R

AVAILABLE FINISHES: **10BE, BSP, C, D, G, WSP**
REPLACEMENT INSERT: **E7 (BL)**
ANSI: **R3G264, R3G265**

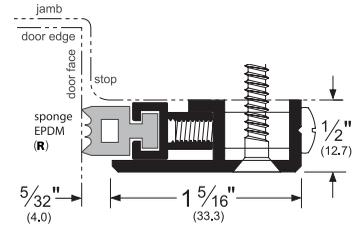

322_SPK

AVAILABLE FINISHES: **10BE, BSP, C, D, WSP**
REPLACEMENT INSERT: **PK121 (BL)**

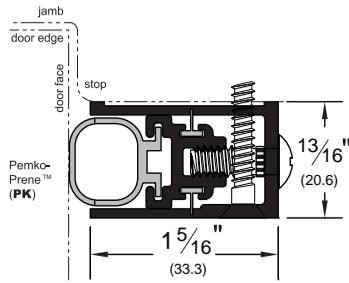

350_SPK

AVAILABLE FINISHES: **10BE, BSP, C, D, WSP**
REPLACEMENT INSERT: **PK4304 (BL)**
ANSI: **R3G164, R3G165**

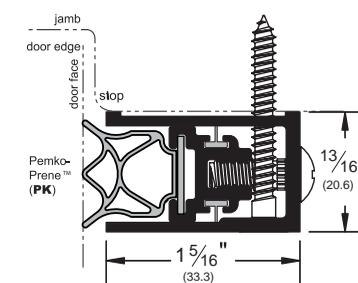

350_SR

AVAILABLE FINISHES: **10BE, BSP, C, D, WSP**
REPLACEMENT INSERT: **E4303 (BL)**
ANSI: **R3G164, R3G165**

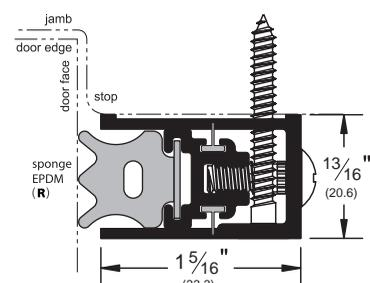

HEAVY DUTY INTERLOCK PERIMETER GASKETING

335_R

AVAILABLE FINISHES: **A**

NOTE: Diagram consists of two parts, each sold separately.

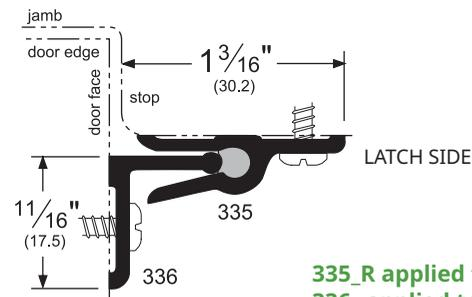

335_R applied to jamb;
336_ applied to door.

336_

AVAILABLE FINISHES: **A**

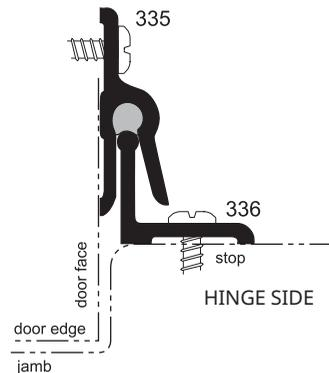

NOTE: Products shown in this section may not be drawn to scale.

AVAILABLE FINISHES FOR PRODUCTS SHOWN ON THIS PAGE

10BE (Satin Bronze Powder Coated Aluminum) **A** (Mill Finish Aluminum) **BSP** (Black Suede Powder Coated Aluminum)
C (Clear Anodized) **D** (Dark Bronze Anodized) **G** (Gold Anodized) **WSP** (White Suede Powder Coated Aluminum)

800-824-3018 | www.pemko.com

Check the web site for the up-to-date catalog

Copyright © 2015-2024, ASSA ABLOY Accessories and Door Controls Group, Inc., an ASSA ABLOY Group company. All rights reserved.
Reproduction in whole or in part without the express written permission of ASSA ABLOY Accessories and Door Controls Group, Inc. is prohibited.

PEMKO
ASSA ABLOY

Experience a safer
and more open world

HEAVY DUTY PERIMETER GASKETING - HEAD SECTION

- For the head section of the frame where a parallel arm closer bracket or other hardware is required. Supplied undrilled (36") or drilled (80" and above) and supplied with sheet metal screws for mounting
- If used as a stop, flat head machine screws can be provided upon request and take a countersunk #10 hole. Pemko will drill the head member only if drilling instructions for countersink holes are provided
- All gasketing shown below is sold individually

2891_PK

AVAILABLE FINISHES: **10BE, A, BSP, D, G, WSP**
 REPLACEMENT INSERT: **PK47 (BL, GR)**
 ANSI: **R3G164, R3G165**

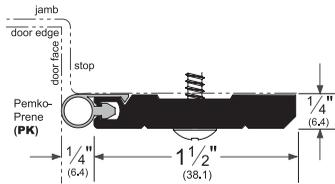

2891_S

AVAILABLE FINISHES: **10BE, A, BSP, D, G, WSP**
 REPLACEMENT INSERT: **S3 (BL, W)**
 ANSI: **R3E164, R3E165**

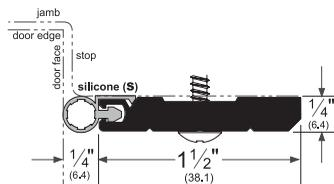

2891_PK

1 per door standard

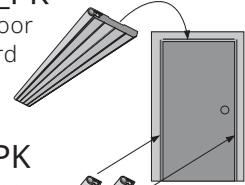

290_PK

2 per door standard



When ordering a head section such as 2891_PK, two corresponding side sections (i.e. 290_PK) should also be ordered for the latch and hinge sides of the frame.

2891_V

AVAILABLE FINISHES: **10BE, A, BSP, D, WSP**
 REPLACEMENT INSERT: **EV47 (BL, GR, W)**

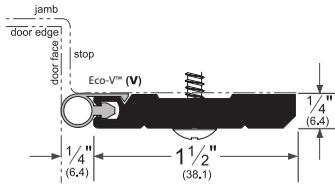

2892_V

AVAILABLE FINISHES: **10BE, A, BSP, D, WSP**
 REPLACEMENT INSERT: **EV59 (BL, GR, W)**

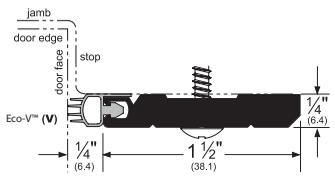

2893_V

AVAILABLE FINISHES: **10BE, A, BSP, D, WSP**
 REPLACEMENT INSERT: **EV60 (GR)**

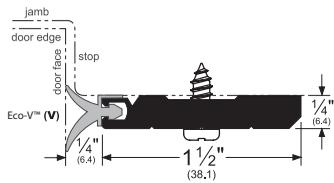

NOTE: Products shown in this section may not be drawn to scale.

AVAILABLE FINISHES FOR PRODUCTS SHOWN ON THIS PAGE

10BE (Satin Bronze Powder Coated Aluminum) **A** (Mill Finish Aluminum) **BSP** (Black Suede Powder Coated Aluminum) **D** (Dark Bronze Anodized) **G** (Gold Anodized) **WSP** (White Suede Powder Coated Aluminum)



Experience a safer and more open world

800-824-3018 | www.pemko.com
 Check the web site for the up-to-date catalog

Copyright © 2015-2024, ASSA ABLOY Accessories and Door Controls Group, Inc., an ASSA ABLOY Group company. All rights reserved. Reproduction in whole or in part without the express written permission of ASSA ABLOY Accessories and Door Controls Group, Inc. is prohibited.

HEAVY DUTY PERIMETER GASKETING - STANDARD JAMB

- For the head section of the frame where a parallel arm closer bracket or other hardware is required. Supplied undrilled (36") or drilled (80" and above) and supplied with sheet metal screws for mounting
- If used as a stop, flat head machine screws can be provided upon request and take a countersunk #10 hole. Pemko will drill the head member only if drilling instructions for countersink holes are provided
- All gasketing shown below is sold individually

290_PK

AVAILABLE FINISHES: **10BE, A, BSP, D, G, WSP**
 REPLACEMENT INSERT: **PK47 (BL, GR)**
 ANSI: **R3G164, R3G165**

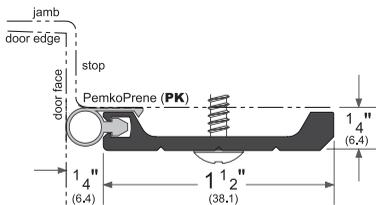

2902_V

AVAILABLE FINISHES: **10BE, A, BSP, D, G, WSP**
 REPLACEMENT INSERT: **EV59 (BL, GR, W)**

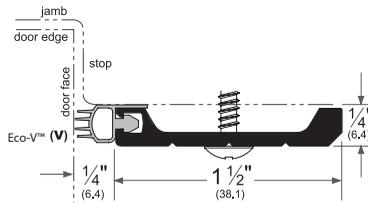

Alternate Inserts For 290

290_S

AVAILABLE FINISHES: **A, D, G**
 REPLACEMENT INSERT: **S3 (BL, W)**
 ANSI: **R3E164, R3E165**



290_V

AVAILABLE FINISHES: **A, D, G**
 REPLACEMENT INSERT: **EV47 (BL, GR, W)**



2903_V

AVAILABLE FINISHES: **10BE, A, BSP, D, G, WSP**
 REPLACEMENT INSERT: **EV60 (GR)**

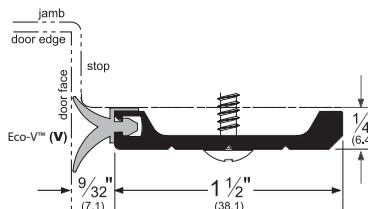

2891_PK

1 per door standard

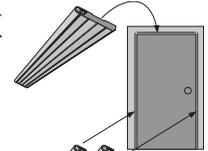

290_PK

2 per door standard

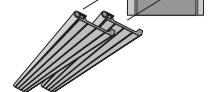

When ordering a head section such as 2891_PK, two corresponding side sections (i.e. 290_PK) should also be ordered for the latch and hinge sides of the frame.

PERIMETER GASKET JAMB BRACKETS

- For use with standard perimeter gasket profiles when opening utilizes a parallel arm closer
- Mount perimeter gasket first, then bracket over the profile. Closer bracket will mount to face of bracket.
- Furnished in paintable galvanized steel (SP) or gray prime coat (G); available in powder coated finishes
- Supplied in 6" lengths

BKT050_

AVAILABLE FINISHES: **10BE, BSP, SP, G, WSP**

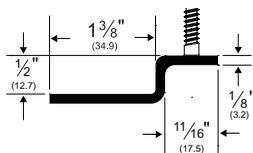

BKT075_

AVAILABLE FINISHES: **10BE, BSP, SP, G, WSP**

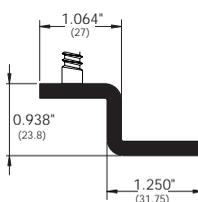

BKT1532_

AVAILABLE FINISHES: **10BE, BSP, SP, G, WSP**

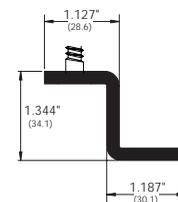

NOTE: Products shown in this section may not be drawn to scale.

AVAILABLE FINISHES FOR PRODUCTS SHOWN ON THIS PAGE
 (see General Information section for finish chart)

10BE (Satin Bronze Powder Coated Aluminum) **A** (Mill Finish Aluminum) **BSP** (Black Suede Powder Coated Aluminum)
D (Dark Bronze Anodized) **G** (Gold Anodized) **WSP** (White Suede Powder Coated Aluminum)

AVAILABLE BRACKET FINISHES FOR PRODUCTS SHOWN ON THIS PAGE

G (Gray Prime Painted Steel) **SP** (Galvanized Steel)

800-824-3018 | www.pemko.com

Check the web site for the up-to-date catalog

Copyright © 2015-2024, ASSA ABLOY Accessories and Door Controls Group, Inc., an ASSA ABLOY Group company. All rights reserved.
 Reproduction in whole or in part without the express written permission of ASSA ABLOY Accessories and Door Controls Group, Inc. is prohibited.



Experience a safer
and more open world

SNAP COVER PERIMETER GASKETING WITH CONCEALED FASTENERS

- Low-profile snap cover conceals mounting screws to provide security and a clean aesthetic appearance
- Cover snaps securely in place to deter vandalism
- All clear anodized brush products are supplied with gray brush (black brush available upon request)

29310_V

AVAILABLE FINISHES: **10BE, BSP, C, D, G, WSP**
REPLACEMENT INSERT: **EV41 (BL, GR, W)**

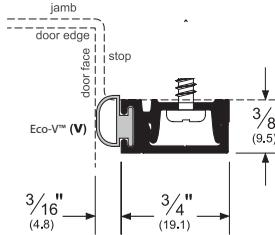

29310_P

AVAILABLE FINISHES: **10BE, BSP, C, D, G, WSP**
REPLACEMENT INSERT: **P2 (BL, GR)**

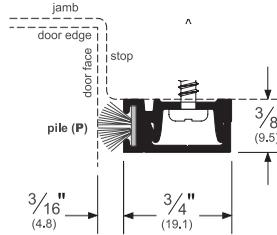

29310_S

AVAILABLE FINISHES: **10BE, BSP, C, D, G, WSP**
REPLACEMENT INSERT: **S4 (BL, GR)**
ANSI: **R3E164, R3E165**

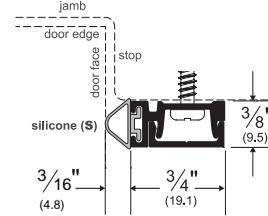

29310_PK

AVAILABLE FINISHES: **10BE, BSP, C, D, G, WSP**
REPLACEMENT INSERT: **S4 (BL, GR)**
ANSI: **R3G164, R3G165**

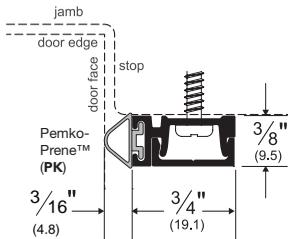

29313_PK

AVAILABLE FINISHES: **10BE, BSP, C, D, WSP**
REPLACEMENT INSERT: **PK588 (BL)**

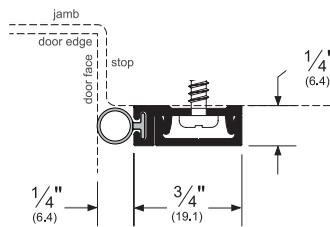

29326_NB

AVAILABLE FINISHES: **10BE, BSP, C, D, G, WSP**
REPLACEMENT INSERT: **P516062 (BL, GR, W)**
ANSI: **R3A164, R3A165**

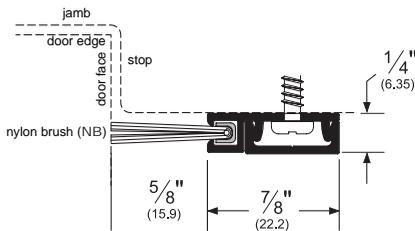

29344_NB

AVAILABLE FINISHES: **10BE, BSP, C, D, G, WSP**
REPLACEMENT INSERT: **P516041 (BL, GR)**
ANSI: **R3A164**

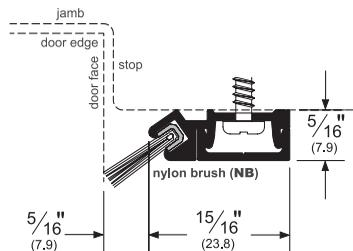

29346_NB

AVAILABLE FINISHES: **10BE, BSP, C, D, G, WSP**
REPLACEMENT INSERT: **P516062 (BL, GR, W)**
ANSI: **R3A164**

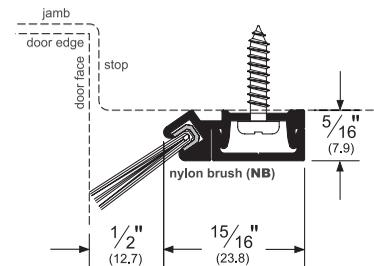

NOTE: Products shown in this section may not be drawn to scale.

AVAILABLE FINISHES FOR PRODUCTS SHOWN ON THIS PAGE

10BE (Satin Bronze Powder Coated Aluminum) **BSP** (Black Suede Powder Coated Aluminum) **C** (Clear Anodized) **D** (Dark Bronze Anodized) **G** (Gold Anodized) **WSP** (White Suede Powder Coated Aluminum)

800-824-3018 | www.pemko.com

Check the web site for the up-to-date catalog

PEMKO
ASSA ABLOY

Experience a safer
and more open world

KERF-IN WEATHERSTRIP

Foam

- Pemko's "Q" foam kerf-in weatherstrip is constructed from soft cell foam enclosed by an embossed, tear-resistant, low-friction, UV-stable polyethylene cover
- Includes rigid PVC insert with extended flange for fast and easy kerf installation

Q102_

AVAILABLE FINISHES: **BL, D, W**
 AVAILABLE LENGTHS: **36", 85", 97", 121"**
 Minimum space between the door face and the stop is $\frac{5}{16}$ "; maximum space is $\frac{1}{2}$ "

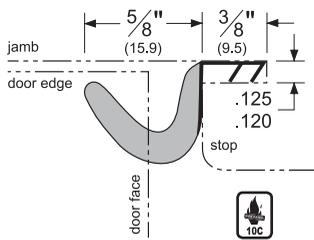

Q103_

AVAILABLE FINISHES: **BL, D, W**
 AVAILABLE LENGTHS: **36", 85", 97", 121"**
 Minimum space between the door face and the stop is $\frac{3}{16}$ "; maximum space is $\frac{5}{16}$ "

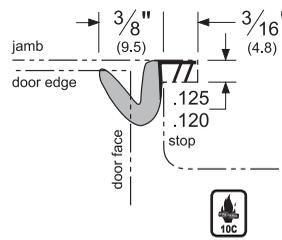

Q106_

AVAILABLE FINISHES: **D, W**
 AVAILABLE LENGTHS: **36", 85", 97", 121"**
 Minimum space between the door face and the stop is $\frac{5}{16}$ "; maximum space is $\frac{1}{2}$ "

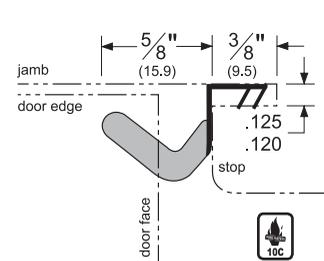

Q107_

AVAILABLE FINISHES: **BL, W**
 Minimum space between the door face and the stop is $\frac{1}{8}$ "; maximum space is $\frac{7}{16}$ "
 Sold per foot (specify length)

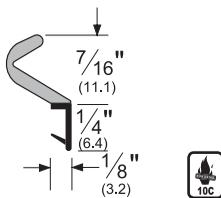

Q108_

AVAILABLE FINISHES: **BL**
 Minimum space between the door face and the stop is $\frac{1}{8}$ "; maximum space is $\frac{1}{2}$ "
 Sold per foot (specify length)

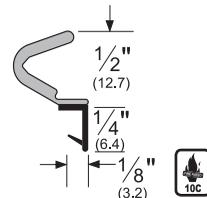

Silicone

- Extruded from platinum cross-linked silicon
- Self-extinguishing and non-toxic
- Unaffected by sunlight, ozone, and ultraviolet rays
- Impervious to fungus and mildew; will not deteriorate under normal exposure
- Available in 100ft lengths

S104_100

AVAILABLE FINISHES: **D, W**
 ANSI: **ROE156**
 Minimum space between the door face and the stop is $\frac{1}{16}$ "; maximum space is $\frac{1}{4}$ "

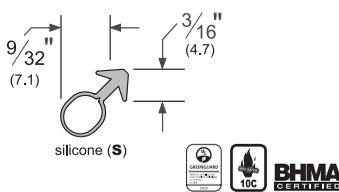

S109_100

AVAILABLE FINISHES: **D, W**
 ANSI: **ROE156**
 Minimum space between the door face and the stop is $\frac{1}{16}$ "; maximum space is $\frac{3}{16}$ "

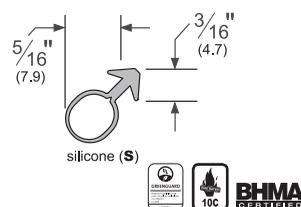

S105_100

AVAILABLE FINISHES: **D, W**
 ANSI: **ROE156**
 Minimum space between the door face and the stop is $\frac{1}{16}$ "; maximum space is $\frac{3}{8}$ "

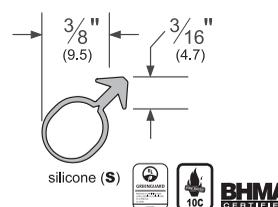

S52_100

AVAILABLE FINISHES: **BL, W**
 ANSI: **ROE154**
 Minimum space between the door face and the stop is $\frac{1}{16}$ "; maximum space is $\frac{3}{8}$ "

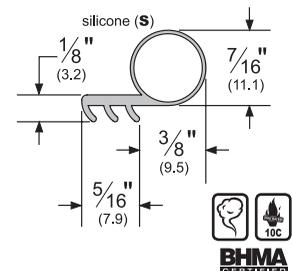

NOTE: Products shown in this section may not be drawn to scale.

AVAILABLE FINISHES FOR PRODUCTS SHOWN ON THIS PAGE

BL (Black) **D** (Black) **W** (White)

800-824-3018 | www.pemko.com

Check the web site for the up-to-date catalog

Copyright © 2015-2024, ASSA ABLOY Accessories and Door Controls Group, Inc., an ASSA ABLOY Group company. All rights reserved. Reproduction in whole or in part without the express written permission of ASSA ABLOY Accessories and Door Controls Group, Inc. is prohibited.

PEMCO
ASSA ABLOY

Experience a safer
 and more open world

KERF-IN WEATHERSTRIP (Cont.)

PK52_

AVAILABLE FINISHES: **BL, W**

ANSI: **ROG154**

AVAILABLE LENGTHS: **18', 20', 300'**

- Minimum space between the door face and the stop is $\frac{1}{16}$ " ; maximum space is $\frac{3}{8}$ "

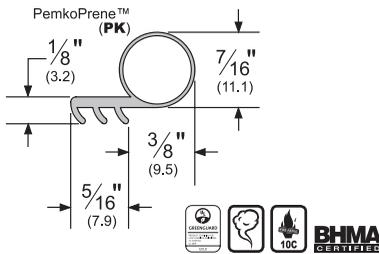

P50_

AVAILABLE FINISHES: **BL, W**

AVAILABLE LENGTHS: **17', 25', 250'**

- Minimum space between the door face and the stop is $\frac{1}{16}$ " ; maximum space is $\frac{5}{16}$ " .
- Thermoplastic elastomer formulation will not transigrate; remains flexible to -60° F

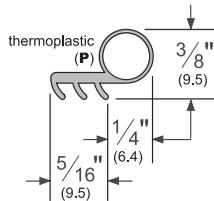

MAG349_

AVAILABLE FINISHES: **D, W**

AVAILABLE LENGTHS: **37", 85", 96", 121"**

- Minimum space between the door face and the stop is $\frac{3}{8}$ " ; maximum space is $\frac{7}{16}$ "
- Magnetic kerf-in weatherstrip features a magnetic strip encased by a UV-stable TPE cover
- Use for steel-faced door and wood frame applications
- Can be trimmed in the field and corner-mitered

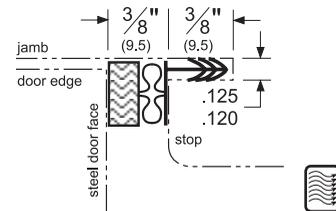

MAGNETIC WEATHERSTRIP

2815_M

AVAILABLE FINISHES: **C, D, G**

REPLACEMENT INSERT: **2815MAG**

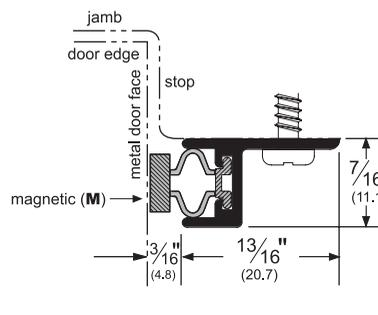

ADHESIVE PERIMETER GASKETING

For more information on these perimeter gasketing products, please see the Adhesive Gasketing section.

S773_

AVAILABLE FINISHES: **BL, D, GR, W**

AVAILABLE LENGTHS: **17', 18', 20', 21', 25', 30', 250', 500'**

ANSI: **ROE154, ROE155**

- Triple-fin design blocks light and sound from infiltrating a room
- Product designed as hospitality gasketing (see more hospitality products in the Hospitality Products section)
- Seal begins compressing at $\frac{3}{8}$ "

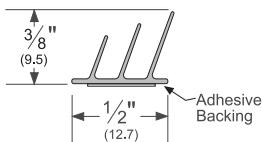

S88_

AVAILABLE FINISHES: **BL, C, D, GR, TAN, W**

AVAILABLE LENGTHS: **17', 18', 20', 21', 25', 30', 204', 510'**

ANSI: **ROE154, ROE155**

- Seal begins compressing at $\frac{1}{4}$ " ; compresses to seal up to a $\frac{1}{16}$ " gap
- Available with perforations for Behavioral Health applications. Substitute "P" in place of "S" to order this option.

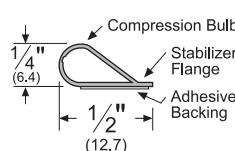

S44_

AVAILABLE FINISHES: **BL, C, D, GR, W**

AVAILABLE LENGTHS: **17', 18', 20', 21', 25', 30', 204', 510'**

ANSI: **ROE154, ROE155**

- Designed for tighter frames.
- Demonstrates extremely low closing force.
- Seal begins compressing at $\frac{5}{16}$ " ; compresses to seal up to a $\frac{1}{16}$ " gap
- Available with perforations for Behavioral Health applications. Substitute "P" in place of "S" to order this option.

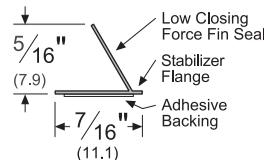

NOTE: Products shown in this section may not be drawn to scale.

AVAILABLE FINISHES FOR PRODUCTS SHOWN ON THIS PAGE

C (Clear Anodized) **D** (Dark Bronze Anodized) **G** (Gold Anodized)

AVAILABLE FINISHES FOR PRODUCTS SHOWN ON THIS PAGE

Adhesive Gasketing Colors: **BL** (Black) **C** (Clear) **D** (Dark Brown) **GR** (Light Gray) **TAN** (Tan) **W** (White)

PEMCO
ASSA ABLOY

Experience a safer
and more open world

ADHESIVE PERIMETER GASKETING (Cont.)

For more information on these perimeter gasketing products, please see the Adhesive Gasketing section.

S442

AVAILABLE FINISHES: **BL, D, W**
 AVAILABLE LENGTHS: **17', 18', 20', 21', 25', 30', 510'**
 ANSI: **R0E154, R0E155**

- Fits flush into corner
- Seal begins compressing at $\frac{5}{16}$ " ; compresses to seal up to a $\frac{1}{16}$ " gap

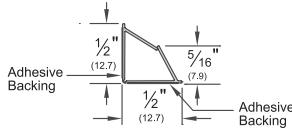

S776

AVAILABLE FINISHES: **BL**
 AVAILABLE LENGTHS: **17', 18', 20', 21', 25', 30'**
 ANSI: **R0E154, R0E155**

- Designed for hollow metal and wood meeting stile applications
- Seal begins compressing at $\frac{3}{8}$ "

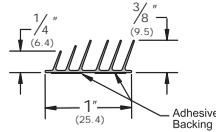

S771x6

AVAILABLE FINISH: **BL**
 AVAILABLE LENGTHS: **7', 8', 10', 17', 18', 20', 21', 25'**
 ANSI: **R0E154, R0E155**

- Designed for hollow metal and wood meeting stile applications
- Seal begins compressing at $\frac{5}{16}$ "

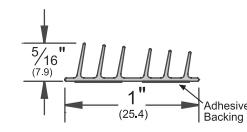

S77

AVAILABLE FINISHES: **C, BL, D, W**
 AVAILABLE LENGTHS: **17', 18', 20', 21', 25', 30', 204', 510'**
 ANSI: **R0E154, R0E155**

- Designed for hollow metal and wood meeting stile applications.
- Seal begins compressing at $\frac{5}{16}$ " ; compresses to seal up to a $\frac{1}{16}$ " gap

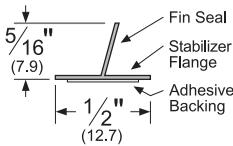

PK33

AVAILABLE FINISHES: **BL, D, W**
 AVAILABLE LENGTHS: **17', 18', 20', 21', 25', 30', 510'**
 ANSI: **R0G154, R0G155**

- Designed for tighter frames.
- Demonstrates extremely low closing force.
- Seal begins compressing at $\frac{3}{16}$ " ; compresses to seal up to a $\frac{1}{16}$ " gap

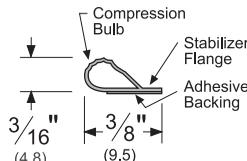

PK55

AVAILABLE FINISHES: **BL, D, W**
 AVAILABLE LENGTHS: **17', 18', 20', 21', 25', 30', 510'**
 ANSI: **R0G154, R0G155**

- Designed for tighter frames.
- Demonstrates extremely low closing force.
- Seal begins compressing at $\frac{3}{16}$ " ; compresses to seal up to a $\frac{1}{16}$ " gap

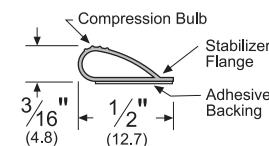

MICROSHIELD® ANTIMICROBIAL ADHESIVE GASKETING

AM88

AVAILABLE FINISHES: **BL, C, D, W**
 AVAILABLE LENGTHS: **17', 18', 20', 21', 25', 30', 510'**
 ANSI: **R8E154, R0E155**

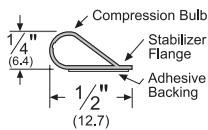

NOTES FOR ALL ADHESIVE GASKETING:
 Storage and shelf life: All adhesive gaskets have a limited shelf life. This product must be installed within 6 months of purchase and must be stored between 50°F and 100°F. For further notes/details, please see Adhesive Gasketing section.

NOTE: Products shown in this section may not be drawn to scale.
 AVAILABLE FINISHES FOR PRODUCTS SHOWN ON THIS PAGE
 Adhesive Gasketing Colors: **BL** (Black) **C** (Clear) **D** (Dark Brown) **W** (White)

800-824-3018 | www.pemko.com
 Check the web site for the up-to-date catalog

Copyright © 2015-2024, ASSA ABLOY Accessories and Door Controls Group, Inc., an ASSA ABLOY Group company. All rights reserved.
 Reproduction in whole or in part without the express written permission of ASSA ABLOY Accessories and Door Controls Group, Inc. is prohibited.



Experience a safer and more open world

EXCESSIVE GAP PERIMETER SOLUTION

XG90KIT

- Brings fire-rated doors with excessive vertical and head gaps back into spec - up to 3/8"
- UL Classified for 90-minutes
- Kit includes all products shown below

HSS20XGxS773

- Pressure sensitive adhesive backing
- AVAILABLE FINISH: **BL**

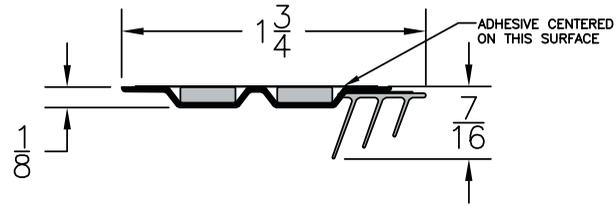

XG900

- 16ga galvanized steel
- Can be screw applied or welded to metal frame.
- If welded, specify with "no holes" for clean appearance.
- Can be field painted to match the frame
- AVAILABLE FINISH: **SP, SPBSP, SPWSP, SP10BE**

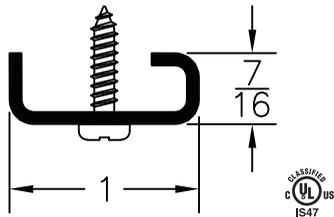

EZGAP™ (XG10 SERIES)

- Flexible, adhesive-applied solution for excessive gaps from 3/32"-1/4"
- Can be used as a full perimeter system or used independently on Latch Edge, Hinge Edge, or Header
- UL10C approved for 45 minute fire rated wood doors with gaps up to 1/4"
- AVAILABLE FINISH: **BL (Black), BR (Brown), GR (Grey), W (White)**
- AVAILABLE LENGTHS: **18 ft, 50 ft Rolls**

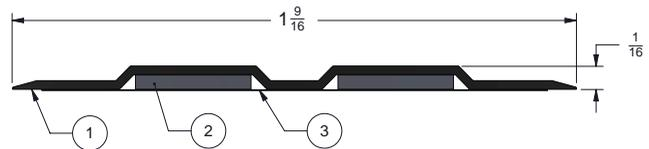

INTERLOCK WEATHERSTRIP FOR WOOD WINDOWS

Corrugated Rib Strips

- Corrugated rib strips are made from .015" spring bronze (B) or .0172" galvanized steel (Z)
- _4C is only available in 96" lengths

_4C (1 3/8" width)
AVAILABLE FINISHES: **B, Z**

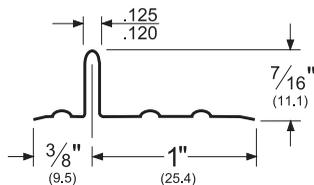

Flat Hooks

- _10 Flat hooks are made from .026" spring bronze (B) or .0172" galvanized steel (Z)

_10
AVAILABLE FINISHES: **B, Z**
AVAILABLE LENGTHS: **96"**

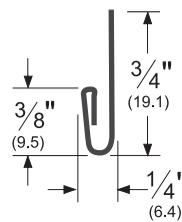

Plain Rib Strips

- Plain rib strips are made from .015" spring bronze (B) or .0172" galvanized steel (Z)

_2P (1" width)
AVAILABLE FINISHES: **B, Z**

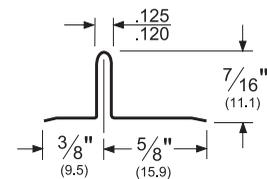

_4P (1 3/8" width)
AVAILABLE FINISHES: **B, Z**

_2P (1" width) shown at left; also available in _4P (1 3/8" width).
_2P and _4P available in 96" lengths only

NOTE: Products shown in this section may not be drawn to scale.

AVAILABLE FINISHES FOR PRODUCTS SHOWN ON THIS PAGE

SP10BE (Satin Bronze Powder) **B** (Bronze) **SPBSP** (Black Suede Powder)
SP (Galvanized Steel) **SPWSP** (White Suede Powder) **Z** (Galvanized Steel)



Experience a safer and more open world

800-824-3018 | www.pemko.com
Check the web site for the up-to-date catalog

Copyright © 2015-2024, ASSA ABLOY Accessories and Door Controls Group, Inc., an ASSA ABLOY Group company. All rights reserved. Reproduction in whole or in part without the express written permission of ASSA ABLOY Accessories and Door Controls Group, Inc. is prohibited.

INTERLOCK WEATHERSTRIP FOR WOOD DOORS

- Fasteners available at additional cost

Liner Strip

- Made from .008" spring bronze (B)

_30

AVAILABLE FINISH: **B**
AVAILABLE LENGTHS: **96"**

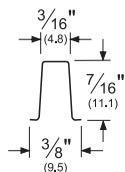

Lock Strip

- Made from .008" spring bronze (B)

_331

AVAILABLE FINISH: **B**
AVAILABLE LENGTHS: **6", 96"**

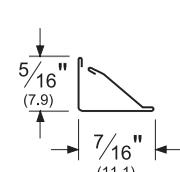

"L" Metal

- Bronze or zinc-plated wafer head drive screws available for _41M (sold separately)

_41M

AVAILABLE FINISHES: **B, Z**
AVAILABLE LENGTHS: **96"**

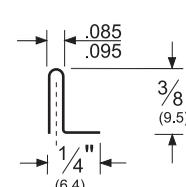

_43

AVAILABLE FINISH: **B**
AVAILABLE LENGTHS: **96"**

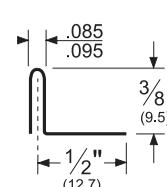

CUSHION/SPRING WEATHERSTRIP FOR WOOD OR METAL DOORS AND WINDOWS

Spring Bronze - Wood Doors/Windows

- Spring bronze weatherstrip fits wood doors and wood casement windows
- Made from .008" hemmed spring bronze/brass (B)
- Nails should be approximately 1 1/2" on center (sold separately)

_70C-100

AVAILABLE FINISH: **B**
AVAILABLE LENGTHS: **100'**

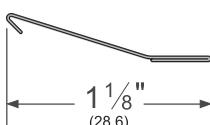

_70D-100

AVAILABLE FINISH: **B**
AVAILABLE LENGTHS: **100'**



_70E-100

AVAILABLE FINISH: **B**
AVAILABLE LENGTHS: **100'**

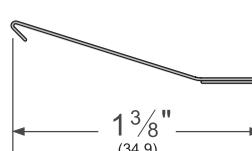

P51B17

P51B17 is 17 feet of _70C
Packaged with nails

CUSHION ("V") - WOOD OR METAL DOORS

- Cushion weatherstrip fits wood or metal doors
- Made from .008" hemmed spring bronze/brass (B)
- Nails should be approximately 3" on center (sold separately)
- Gap coverage is 1/8" minimum to 3/16" maximum

_73

AVAILABLE FINISH: **B**
AVAILABLE LENGTHS: **96"**

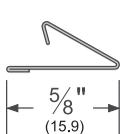

_74

AVAILABLE FINISH: **B**
AVAILABLE LENGTHS: **96"**

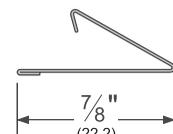

_75

AVAILABLE FINISH: **B**
AVAILABLE LENGTHS: **96"**

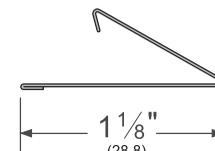

FASTENERS FOR CUSHION, SPRING AND INTERLOCK WEATHERSTRIP

- Fasteners for cushion, spring, and interlock weatherstrip are sold separately unless otherwise specified

NL1678_

AVAILABLE FINISHES: **BL, BP, Z**
For Wood: #16 x 7/8" flat head nail



NL1734CPXE_

AVAILABLE FINISHES: **BB, SS**
For Wood: #16 x 3/4" flat head nail



NOTE: Copper nails may be substituted for "BB" nails while brass remains unavailable.

800-824-3018 | www.pemko.com

Check the web site for the up-to-date catalog

Copyright © 2015-2024, ASSA ABLOY Accessories and Door Controls Group, Inc., an ASSA ABLOY Group company. All rights reserved.
Reproduction in whole or in part without the express written permission of ASSA ABLOY Accessories and Door Controls Group, Inc. is prohibited.

PEMCO
ASSA ABLOY

Experience a safer
and more open world



PEMKO ADHESIVE GASKETING

CONTENTS:

SiliconSeal Adhesive-Backed Fire/Smoke Gasketing	186
PemkoPrene® Adhesive-Backed Fire/Smoke Gasketing	187
SiliconSeal Adhesive-Backed Meeting Stile Gasketing	187
MicroShield® Antimicrobial Gasketing	188
Hot Smoke Seal/SiliconSeal Combination Fire/Smoke Sealing	188

INDEX:

<u>PRODUCT</u>	<u>PAGE</u>	<u>PRODUCT</u>	<u>PAGE</u>
AM88	188	S77	186
HSS1000.....	188	S88.....	186
HSS2000	188	S442	186
HSS2000xS44	188	S771.....	187
HSS2000xS88	187	S771x6.....	187
HSS7750	188	S772.....	187
PK33	187	S773.....	186
PK55	187	S776.....	186
S44.....	186		

800-824-3018 | www.pemko.com

Check the web site for the up-to-date catalog

Copyright © 2015-2024, ASSA ABLOY Accessories and Door Controls Group, Inc., an ASSA ABLOY Group company. All rights reserved.
Reproduction in whole or in part without the express written permission of ASSA ABLOY Accessories and Door Controls Group, Inc. is prohibited.

PEMKO
ASSA ABLOY

Experience a safer
and more open world

SILICONSEAL ADHESIVE-BACKED FIRE/SMOKE GASKETING

- SiliconSeal is extruded from high-temperature silicone; effective between -58°F and 450°F
- Self-extinguishing and non-toxic; unaffected by sunlight, ozone, and ultraviolet rays
- Impervious to fungus and mildew; will not deteriorate under normal exposure
- Meets FAR 25.853 Airworthiness Standards for Compartment Interiors

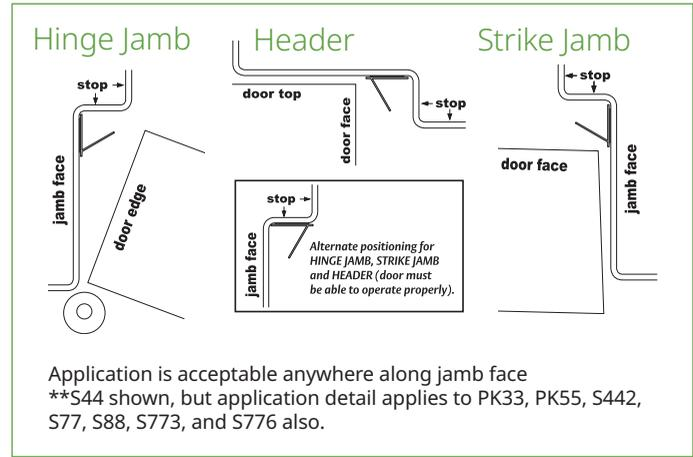

S44_

AVAILABLE FINISHES: **BL, C, D, GR, W**
 AVAILABLE LENGTHS: **17', 18', 20', 21', 25', 30', 204', 510'**
 ANSI: **ROE154, ROE155**

- Designed for tighter frames
- Demonstrates extremely low closing force
- Seal begins compressing at $5/16"$; compresses to seal up to a $1/16"$ gap

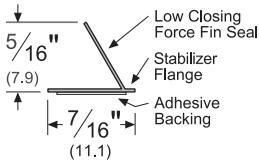

S442_

AVAILABLE FINISHES: **BL, D, W**
 AVAILABLE LENGTHS: **17', 18', 20', 21', 25', 30', 510'**
 ANSI: **ROE154, ROE155**

- Fits flush into corner
- Seal begins compressing at $5/16"$; compresses to seal up to a $1/16"$ gap in either direction

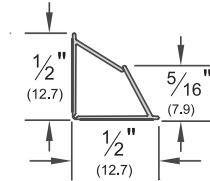

S77_

AVAILABLE FINISHES: **BL, C, D, W**
 AVAILABLE LENGTHS: **17', 18', 20', 21', 25', 30', 204', 500'**
 ANSI: **ROE154, ROE155**

- Designed for hollow metal and wood meeting stile applications
- Seal begins compressing at $5/16"$; compresses to seal up to a $1/16"$ gap

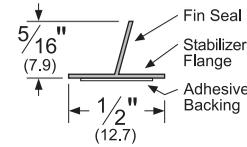

S88_

AVAILABLE FINISHES: **BL, C, D, GR, TAN, W**
 AVAILABLE LENGTHS: **17', 18', 20', 21', 25', 30', 204', 510'**
 ANSI: **ROE154, ROE155**

- Seal begins compressing at $1/4"$; compresses to seal up to a $1/16"$ gap

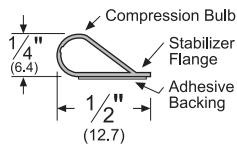

S773_

AVAILABLE FINISHES: **BL, D, GR, W**
 AVAILABLE LENGTHS: **17', 18', 20', 21', 25', 30', 250', 500'**
 ANSI: **ROE154, ROE155**

- Triple-fin design effectively blocks light and sound from infiltrating a room
- Seal begins compressing at $3/8"$; compresses to seal up to a $3/32"$ gap

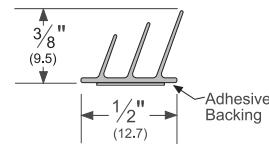

S776_

AVAILABLE FINISHES: **BL**
 AVAILABLE LENGTHS: **17', 18', 20', 21', 25', 30'**
 ANSI: **ROE154, ROE155**

- Designed for hollow metal and wood meeting stile applications
- Seal begins compressing at $3/8"$

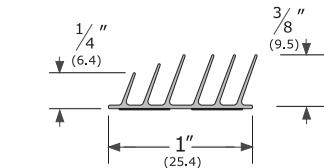

PEMKO
ASSA ABLOY

Experience a safer and more open world

AVAILABLE FINISHES FOR PRODUCTS SHOWN ON THIS PAGE

BL (Black) **C** (Clear) **D** (Dark Brown) **GR** (Light Gray) **TAN** (Tan) **W** (White)

800-824-3018 | www.pemko.com
 Check the web site for the up-to-date catalog

Copyright © 2015-2024, ASSA ABLOY Accessories and Door Controls Group, Inc., an ASSA ABLOY Group company. All rights reserved. Reproduction in whole or in part without the express written permission of ASSA ABLOY Accessories and Door Controls Group, Inc. is prohibited.

PEMKOPRENE® ADHESIVE-BACKED FIRE/SMOKE GASKETING

PK33_

AVAILABLE FINISHES: **BL, D, W**
 AVAILABLE LENGTHS: **17', 18', 20', 21', 25', 30', 510'**
 ANSI: **ROG154, ROG155**

- Designed for tighter frames
- Demonstrates extremely low closing force
- Seal begins compressing at $\frac{3}{16}$ " ; compresses to seal up to a $\frac{1}{16}$ " gap

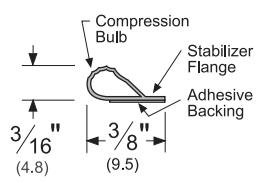

PK55_

AVAILABLE FINISHES: **BL, D, W**
 AVAILABLE LENGTHS: **17', 18', 20', 21', 25', 30', 510'**
 ANSI: **ROG154, ROG155**

- Designed for tighter frames
- Demonstrates extremely low closing force
- Seal begins compressing at $\frac{3}{16}$ " ; compresses to seal up to a $\frac{1}{16}$ " gap

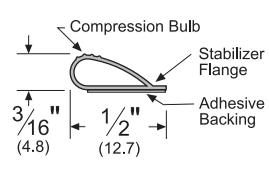

SILICONSEAL ADHESIVE-BACKED MEETING STILE GASKETING

- Excellent resistance to compression set, particularly at elevated temperatures and for extended periods of time
- Outstanding ozone resistance rating
- Smoke tested in accordance with UL1784; meets the requirements of NFPA 105 "Standard for the Installation of Smoke Door Assemblies and Other Opening Protectives"

S771_

AVAILABLE FINISHES: **BL, C, D, W**
 AVAILABLE LENGTHS: **7', 8', 9', 10'**
 ANSI: **ROE154, ROE155, ROE754, ROE755**

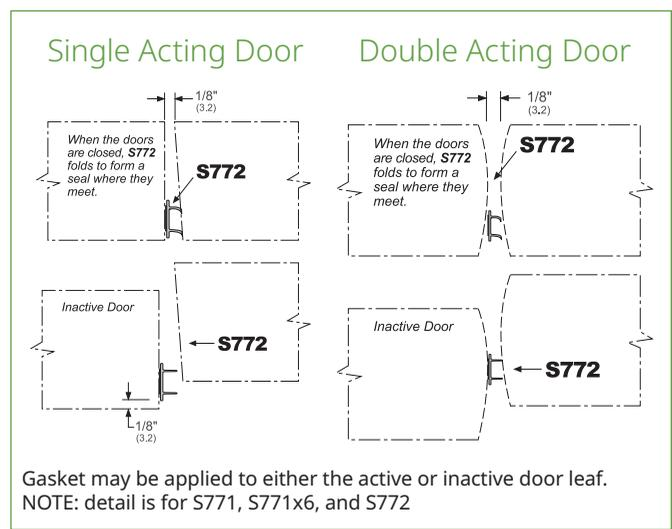
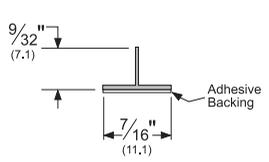

S771x6_

AVAILABLE FINISHES: **BL**
 AVAILABLE LENGTHS: **7', 8', 9', 10'**
 ANSI: **ROE154, ROE155, ROE754, ROE755**

- Designed for hollow metal and wood meeting stile applications
- Seal begins compressing at $\frac{5}{16}$ "

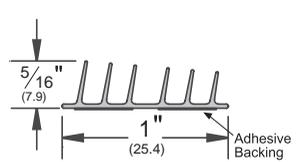

S772_

AVAILABLE FINISHES: **BL, C, D, W**
 AVAILABLE LENGTHS: **7', 8', 9', 10'**
 ANSI: **ROE154, ROE155, ROE754, ROE755**

- Designed for tighter frames
- Demonstrates extremely low closing force
- Seal begins compressing at $\frac{3}{16}$ " ; compresses to seal up to a $\frac{1}{16}$ " gap

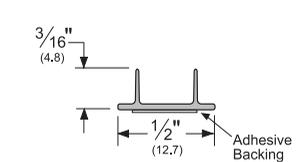

AVAILABLE FINISHES FOR PRODUCTS SHOWN ON THIS PAGE
BL (Black) **C** (Clear) **D** (Dark Brown) **W** (White)

800-824-3018 | www.pemko.com
 Check the web site for the up-to-date catalog

Copyright © 2015-2024, ASSA ABLOY Accessories and Door Controls Group, Inc., an ASSA ABLOY Group company. All rights reserved.
 Reproduction in whole or in part without the express written permission of ASSA ABLOY Accessories and Door Controls Group, Inc. is prohibited.



Experience a safer
 and more open world

MICROSHIELD® ANTIMICROBIAL GASKETING

- Extruded from high-temperature silicone with MicroShield®, a silver-based antimicrobial additive
- Effective between -58°F and 450°F
- Adhesive Backed

- Self-extinguishing and non-toxic
- Unaffected by sunlight, ozone and ultraviolet rays
- Exceeds the requirements for Antimicrobial Test JIS-Z-2801

AM88

AVAILABLE FINISHES: **BL, C, D, W**
 AVAILABLE LENGTHS: **17', 18', 20', 21', 25', 30', 510'**
 ANSI: **ROE154, ROE155**

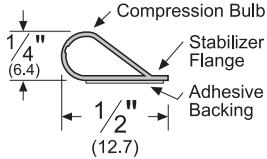

MicroShield®
 As part of their promise to provide innovative solutions to their customers, certain ASSA ABLOY Group brands offer the MicroShield® technology, a silver-based antimicrobial additive designed to inhibit the growth of bacteria.

MicroShield® is a registered trademark of Yale Security Inc., an ASSA ABLOY Group company.

HOT SMOKE SEAL/SILICONSEAL COMBINATION FIRE/SMOKE SEALING

- Chemically inert, highly stable, expandable graphite strip
- Tested and proven in positive pressure conditions to withstand both hot smoke and hot gasses, resulting in longer integrity of the door assembly
- More economical to use than specially modified doors in "tested assembly only" classifications

- Hot Smoke Seal can be painted to blend in with the finish of a frame
- Will not degrade from carbon dioxide and ozone like many competitive intumescent from other manufacturers
- Unaffected by moisture and will not break down like fiber-based or cellulose-based products

HSS1000

AVAILABLE FINISHES: Graphite (no finish code)
 AVAILABLE LENGTHS: **7', 8', 10', 18', 21', 24'**
 ANSI: **ROP124**

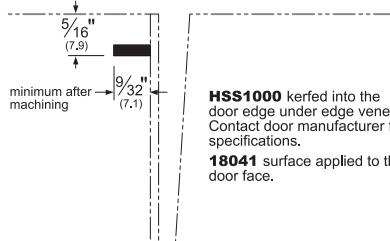
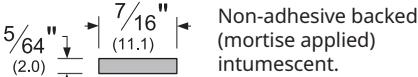

HSS1000 kerfed into the door edge under edge veneer. Contact door manufacturer for specifications.
18041 surface applied to the door face.

NOTES FOR ALL ADHESIVE GASKETING:

Storage and shelf life: All adhesive gaskets have a limited shelf life. This product must be installed within 6 months of purchase and must be stored between 50°F and 100°F. Before installing: Thoroughly clean the frame to remove grease, dust or cleanser build-up (cleansing towelettes are included with product). Painted frame surface must be completely dry. Some hospital environments have wax or anti-bacterial cleanser build-up. As an alternative or substitute cleanser, use isopropyl (rubbing) alcohol. Note: Mineral spirits or other petroleum based cleaning products should NOT be used.

HSS2000

AVAILABLE FINISHES: Graphite (no finish code)
 AVAILABLE LENGTHS: **7', 8', 10', 18', 21', 24'**
 ANSI: **ROP154**

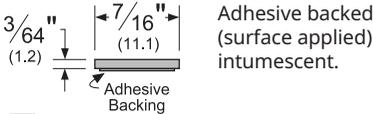

HSS2000xS44

AVAILABLE FINISHES: **BL, C, D, GR, W**
 AVAILABLE LENGTHS: **18', 20', 21', 24'**
 20' lengths can be supplied in 4-0 x 8-0 or 6-0 x 7-0. Specify when ordering
 ANSI: **ROU154, ROU155**

- Compresses to seal a gap up to 1/8"

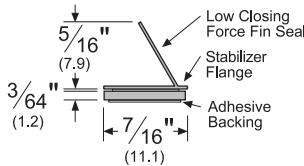

HSS2000xS88

AVAILABLE FINISHES: **BL, C, D, GR, W**
 AVAILABLE LENGTHS: **18', 20', 21', 24'**
 20' lengths can be supplied in 4-0 x 8-0 or 6-0 x 7-0. Specify when ordering
 ANSI: **ROU154, ROU155**

- Compresses to seal a gap up to 1/8"

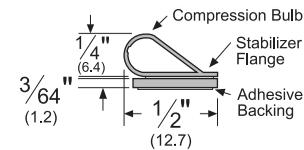

HSS7750

AVAILABLE FINISHES: **BL**
 AVAILABLE LENGTHS: **36", 48", 84", 96"**

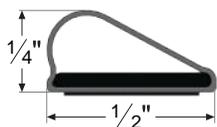

AVAILABLE FINISHES FOR PRODUCTS SHOWN ON THIS PAGE
BL (Black) **C** (Clear) **D** (Dark Brown) **GR** (Light Gray) **W** (White)



Experience a safer and more open world

800-824-3018 | www.pemko.com
 Check the web site for the up-to-date catalog

Copyright © 2015-2024, ASSA ABLOY Accessories and Door Controls Group, Inc., an ASSA ABLOY Group company. All rights reserved. Reproduction in whole or in part without the express written permission of ASSA ABLOY Accessories and Door Controls Group, Inc. is prohibited.

PEMKO HOSPITALITY PRODUCTS

CONTENTS:

Privacy Door Latch, Bracket and Decals.....	190
SiliconSeal Adhesive Gasketing.....	191
Automatic Door Bottoms: Acoustic.....	192
Door Shoes.....	192
Acoustic Adhesive Corner Pads.....	192
Automatic Door Bottoms.....	193
Eco-V™ Thresholds.....	194
Adjustable-Width Eco-V™ Threshold.....	195
Stainless Steel Sliding Track Hardware System.....	196
Cascading Door with Sample Configurations.....	197
SHS80 System.....	198
Bypass Track Series.....	199

INDEX:

PRODUCT	PAGE	PRODUCT	PAGE
411.....	193	H222R1.....	197
601H.....	197	HBP200A.....	199
1076.....	197	PDLAA.....	190
2113.....	192	PDLBRKT.....	190
2173.....	192	PDL-D1.....	190
2343.....	192	PDL-D2.....	190
2802.....	197	S44.....	191
2812.....	197	S88.....	191
3692.....	192	S442.....	191
4131.....	193	S771.....	191
ACP112.....	192	S771x6.....	191
ADJ232V8.....	195	S772.....	191
ADJ232V14.....	195	S773.....	191
ADJ232x2325V8.....	195	S776.....	191
EV232.....	194	SHS80.....	198
EV2320.....	194	STC411.....	192
EV2322.....	194	STC4131.....	192
EV2325.....	194	W60.....	196
EV2326.....	194		

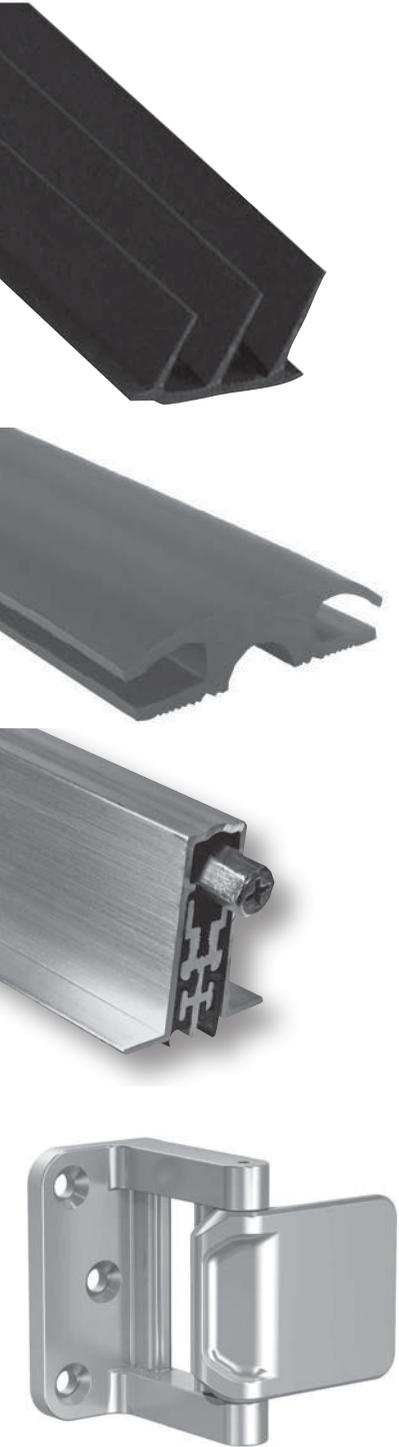

800-824-3018 | www.pemko.com

Check the web site for the up-to-date catalog

Copyright © 2015-2024, ASSA ABLOY Accessories and Door Controls Group, Inc., an ASSA ABLOY Group company. All rights reserved.
 Reproduction in whole or in part without the express written permission of ASSA ABLOY Accessories and Door Controls Group, Inc. is prohibited.

PEMKO
ASSA ABLOY

Experience a safer
 and more open world

PRIVACY DOOR LATCH

- Easy to install, simple to operate
- ADA Compliant
- Enhances room privacy
- UL Classified as a fire door accessory

PDLAA_

AVAILABLE COLORS:

- PDLAA26 Polished Chrome
- PDLAA26D/15 Polished Chrome/Satin Nickel
- PDLAA3 Polished Brass
- PDLAA4 Brushed Brass
- PDLAABSP Black Suede
- PDLAA10BE Dark Oxidized
- Satin Bronze, Equivalent

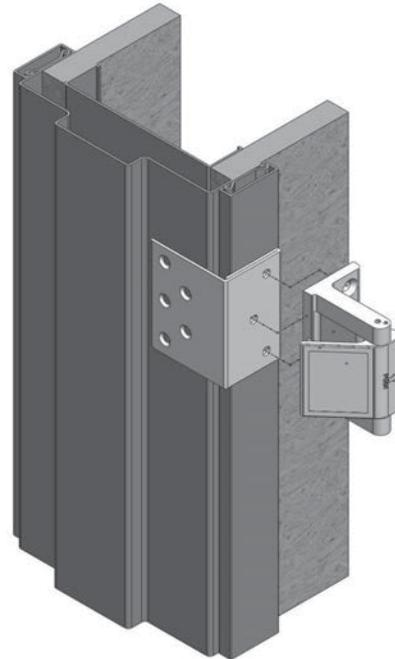
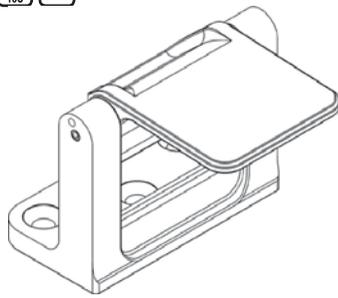
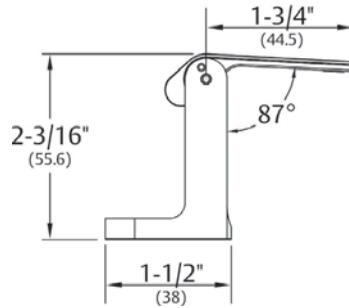

PRIVACY DOOR LATCH BRACKET

- Designed for Timely or Redi-Frame frames with snap on trim
- Bracket allows PDL to be installed in the correct position for proper operation
- Custom powder coat options available.

PDLBRKT_

- AVAILABLE COLORS:
- Paintable Galvannealed (blank)
 - Black Suede (BSP)
 - Satin Bronze (10BE)
 - White Suede (WSP)

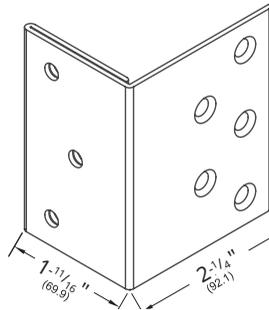

PRIVACY DOOR LATCH DECALS

- Used to cover holes left on door and frame from old style door latch. Per NFPA80 holes must first be filled with like material in order to maintain the fire opening rating
- Made from stable, mar-resistant plastic
- Sub-surface screen printing so verbiage will not be affected by gentle cleaning/dusting



PDL-D1



PDL-D2



Experience a safer
and more open world

SILICONSEAL ADHESIVE GASKETING

S44_

AVAILABLE FINISHES: **BL, C, D, GR, W**
 AVAILABLE LENGTHS: **17', 18', 20', 21', 25', 30', 204', 510'**
 ANSI: **ROE154, ROE155**

- Designed for tighter frames
- Demonstrates extremely low closing force
- Seal begins compressing at $\frac{5}{16}$ " ; compresses to seal up to a $\frac{1}{16}$ " gap



S88_

AVAILABLE FINISHES: **BL, C, D, GR, TAN, W**
 AVAILABLE LENGTHS: **17', 18', 20', 21', 25', 30', 204', 510'**
 ANSI: **ROE154, ROE155**

- Seal begins compressing at $\frac{1}{4}$ " ; compresses to seal up to a $\frac{1}{16}$ " gap

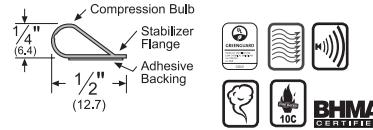

S442_

AVAILABLE FINISHES: **BL, D, W**
 AVAILABLE LENGTHS: **17', 18', 20', 21', 25', 30', 510'**
 ANSI: **ROE154, ROE155**

- Seal fits flush into corner
- Seal begins compressing at $\frac{5}{16}$ " ; compresses to seal up to a $\frac{1}{16}$ " gap in either direction

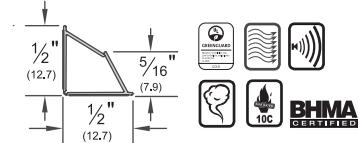

S771_

AVAILABLE FINISHES: **BL, C, D, W**
 AVAILABLE LENGTHS: **7', 8', 9', 10'**
 ANSI: **ROE154, ROE155, ROE754, ROE755**

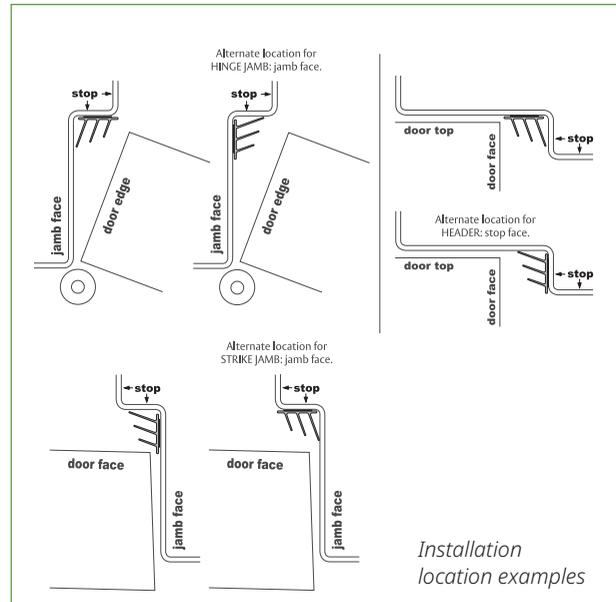
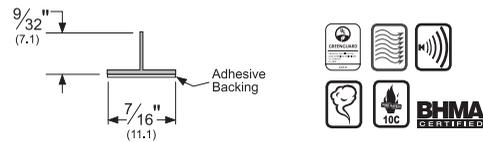

S772_

AVAILABLE FINISHES: **BL, C, D, W**
 AVAILABLE LENGTHS: **7', 8', 9', 10'**
 ANSI: **ROE154, ROE155, ROE754, ROE755**

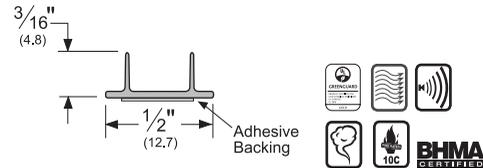

S773_

AVAILABLE FINISHES: **BL, D, GR, W**
 AVAILABLE LENGTHS: **17', 18', 20', 21', 25', 30', 250', 500'**
 ANSI: **ROE154, ROE155**

- Triple-fin design effectively blocks light and sound from infiltrating a room
- Seal begins compressing at $\frac{3}{8}$ " ; compresses to seal up to a $\frac{3}{32}$ " gap

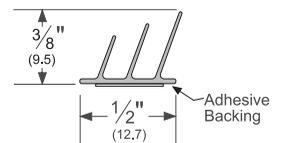

S776_

AVAILABLE FINISHES: **BL**
 AVAILABLE LENGTHS: **17', 18', 20', 21', 25', 30'**
 ANSI: **ROE154, ROE155**

- Designed for hollow metal and wood meeting stile applications
- Seal begins compressing at $\frac{3}{8}$ "

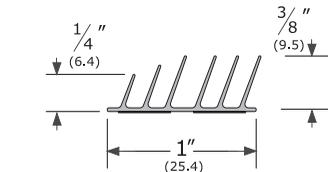

S771x6_

AVAILABLE FINISHES: **BL**
 AVAILABLE LENGTHS: **7', 8', 9', 10'**
 ANSI: **ROE154, ROE155, ROE754, ROE755**

- Designed for hollow metal and wood meeting stile applications
- Seal begins compressing at $\frac{5}{16}$ "

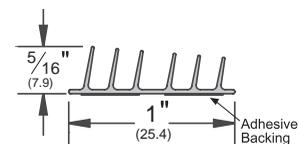

AVAILABLE FINISHES FOR PRODUCTS SHOWN ON THIS PAGE
BL (Black) **C** (Clear) **D** (Dark Brown) **GR** (Light Gray) **TAN** (Tan) **W** (White)

800-824-3018 | www.pemko.com

Check the web site for the up-to-date catalog

Copyright © 2015-2024, ASSA ABLOY Accessories and Door Controls Group, Inc., an ASSA ABLOY Group company. All rights reserved.
 Reproduction in whole or in part without the express written permission of ASSA ABLOY Accessories and Door Controls Group, Inc. is prohibited.

PEMKO
ASSA ABLOY

Experience a safer
 and more open world

AUTOMATIC DOOR BOTTOMS - ACOUSTIC

- Recommended gap under door is $\frac{3}{8}$ " for optimal acoustic performance; max drop is $\frac{3}{4}$ "
- Internal mechanism allows bar to accommodate slight imperfections in floor materials
- STC411 end plate kit is K435; for doors narrower than $1-\frac{3}{4}$ ", specify end plate kit K411
- STC4131 end plate kit is K4133C for Clear Anodized and K4133D for Dark Bronze Anodized
- Non-handed

STC411_PK

AVAILABLE FINISHES: **A**
REPLACEMENT INSERT:
PK4111 (BL)
ANSI: **R3G324, R3G325**

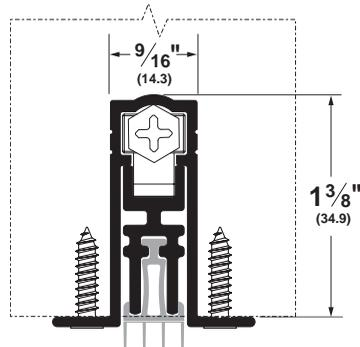

STC4131_PK

AVAILABLE FINISHES: **10BE, BSP, C, D, WSP**
REPLACEMENT INSERT: **PK4111 (BL)**
ANSI: **R3G334, R3G335, R3G344, R3G345**

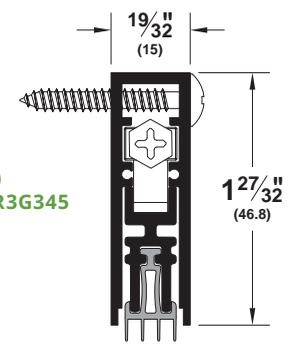

Door Shoes

2173_V

AVAILABLE FINISHES:
A, BSP, D, G, WSP
AVAILABLE LENGTHS:
36", 48"
REPLACEMENT INSERT:
EV94 (BL)
ANSI:
R3D414, R3D415

Also available with unnotched insert:

2173_V36UN
2173_V48UN

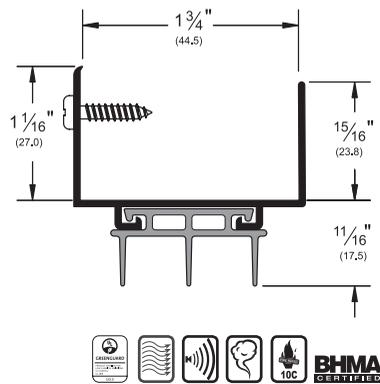

2113_V

AVAILABLE FINISHES:
A, BSP, D, G, WSP
AVAILABLE LENGTHS:
36", 48"
REPLACEMENT INSERT:
EV94 (BL)
ANSI:
R3D414, R3D415

Also available with unnotched insert:

2113_V36UN
2113_V48UN

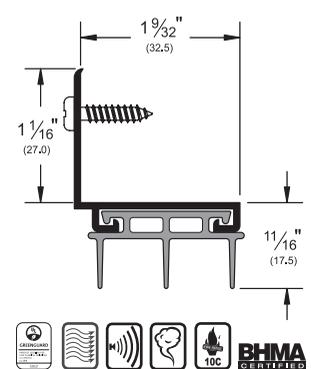

3692_PK773

AVAILABLE FINISH:
A
AVAILABLE LENGTHS:
36", 48"
REPLACEMENT INSERT:
PK773 (BL, GR)
ANSI:
R3G414, R3G415

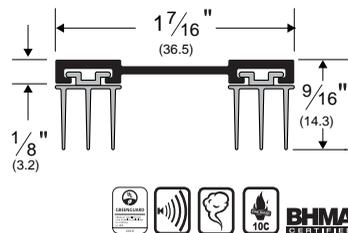

2343_V

AVAILABLE FINISHES:
A, BSP, D, G
AVAILABLE LENGTHS:
36", 48"
REPLACEMENT INSERT: **EV94 (BL)**
ANSI: **R3D414, R3D415**
Also available with unnotched insert:

2343_V36UN
2343_V48UN

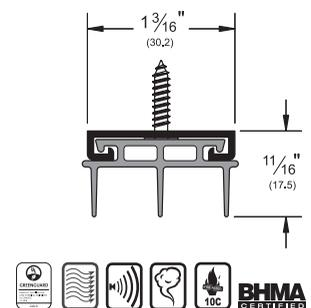

ACOUSTIC ADHESIVE CORNER PADS

- Corner pad with black or white polypropylene pile, with pressure-sensitive adhesive
- Apply to corner of jamb on hinge side to seal against air and light infiltration

ACP112_

AVAILABLE COLORS: **BL, W**

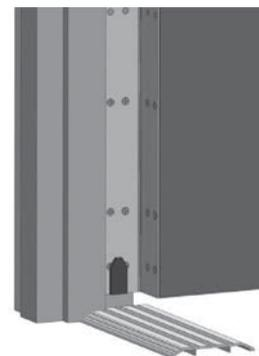
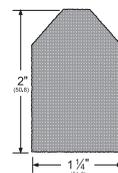

AVAILABLE FINISHES FOR PRODUCTS SHOWN ON THIS PAGE
10BE (Satin Bronze Powder Coated Aluminum) **A** (Mill Finish Aluminum)
BSP (Black Suede Powder Coated Aluminum) **D** (Dark Bronze Anodized) **G** (Gold Anodized)
WSP (White Suede Powder Coated Aluminum) Corner Pad: **BL** (Black) **W** (White)

PEMKO
ASSA ABLOY

Experience a safer
and more open world

800-824-3018 | www.pemko.com
Check the web site for the up-to-date catalog

Copyright © 2015-2024, ASSA ABLOY Accessories and Door Controls Group, Inc., an ASSA ABLOY Group company. All rights reserved. Reproduction in whole or in part without the express written permission of ASSA ABLOY Accessories and Door Controls Group, Inc. is prohibited.

AUTOMATIC DOOR BOTTOMS

- All Pemko Automatic Door Bottoms, 24" and up, can be manufactured for field alteration.
- Please specify when ordering: Allow 2" for field trimming

411_NBL

AVAILABLE FINISH:

- A**
- REPLACEMENT INSERT:
P14075 (BL, GR)
- ANSI:
R3A324, R3A325

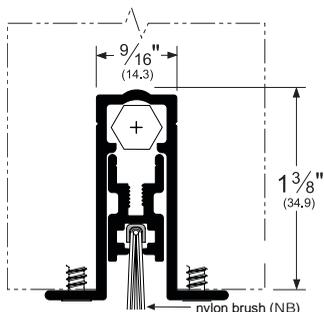

nylon brush (NB)



411_RL

AVAILABLE FINISH:

- A**
- REPLACEMENT INSERT:
E7 (BL)
- ANSI:
R3G324, R3G325

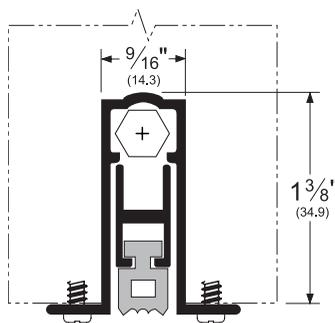

sponge EPDM (R)



Alternate Insert For 411

411_PKL

- AVAILABLE FINISH:
A
- REPLACEMENT INSERT:
PK4132 (BL)
- ANSI: **R3G324, R3G325**



411_SL

- AVAILABLE FINISH:
A
- REPLACEMENT INSERT:
SR6 (BL)
- ANSI:
R3E324, R3E325

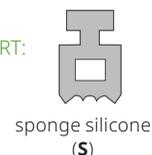

All above products



4131_NBL

AVAILABLE FINISHES:

- BSP, C, D, SN**
- REPLACEMENT INSERT:
P14075 (BL, GR)
- ANSI:
R3A334, R3A335, R3A344, R3A345

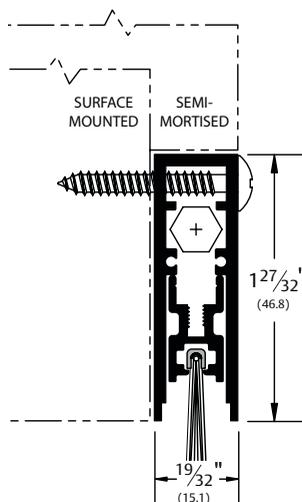

nylon brush (NB)



4131_RL

AVAILABLE FINISHES:

- BSP, C, D, SN**
- REPLACEMENT INSERT:
E7 (BL)
- ANSI:
R3G334, R3G335, R3G344, R3G345

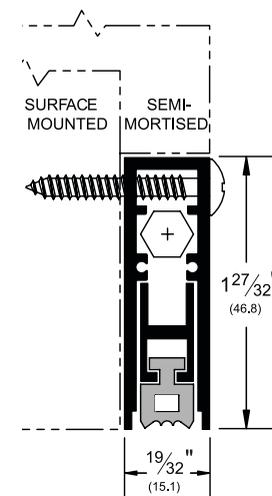

sponge EPDM (R)



Alternate Inserts For 4131

4131_PKL

- AVAILABLE FINISHES:
BSP, C, D, SN
- REPLACEMENT INSERT:
PK4132 (BL)
- ANSI: **R3G334, R3G335, R3G344, R3G345**



4131_SL

- AVAILABLE FINISHES:
BSP, C, D, SN
- REPLACEMENT INSERT:
SR6 (BL)
- ANSI: **R3E334, R3E335, R3E344, R3E345**

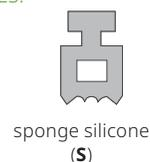

All above products



AVAILABLE FINISHES FOR PRODUCTS SHOWN ON THIS PAGE

- 10BE** (Satin Bronze Powder Coated Aluminum) **A** (Mill Finish Aluminum)
- BSP** (Black Suede Powder Coated Aluminum) **C** (Clear Anodized) **D** (Dark Bronze Anodized)
- WSP** (White Suede Powder Coated Aluminum) **SN** (Satin Nickel Anodized)

800-824-3018 | www.pemko.com

Check the web site for the up-to-date catalog

Copyright © 2015-2024, ASSA ABLOY Accessories and Door Controls Group, Inc., an ASSA ABLOY Group company. All rights reserved. Reproduction in whole or in part without the express written permission of ASSA ABLOY Accessories and Door Controls Group, Inc. is prohibited.



Experience a safer and more open world

ECO-V™ THRESHOLDS

- Eco-V™ thresholds create an ideal transition where two different pieces of carpet meet, or carpet meets another surface under a door
- Ideal for use in any high-traffic commercial installation, such as hotels and offices
- Eco-V™ thresholds are manufactured from slightly softer material than competitive products. This aids in the cutting and fitting of the threshold and facilitates easier insertion of the carpet into the holding cavities on the carpet side(s) of the threshold

- Eco-V™ thresholds are designed to work in conjunction with Pemko's **2173_V**, **2113_V** and **2343_V** door shoes
- **EV232**, **EV2325**, and **ADJ232V** thresholds meet the criteria outlined in **ADAAG-2010 (Amended)**; **ICC/ANSI A117.1** and **California Building Code, Title 24** for Barrier-Free Entry - ½" max rise above finished floor

EV232_

AVAILABLE COLORS: **BL, D**
 AVAILABLE LENGTHS: **36", 48", 73"**
 Serves as a transition where two pieces of carpet meet beneath an interior door

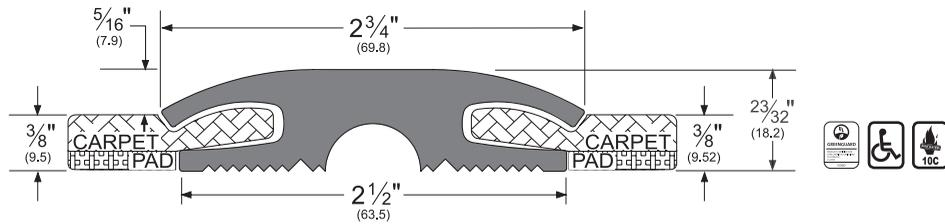

EV2325_

AVAILABLE COLORS: **BL, D**
 AVAILABLE LENGTHS: **36", 48", 73"**
 Serves as a transition where one piece of carpet meets tile beneath an interior door

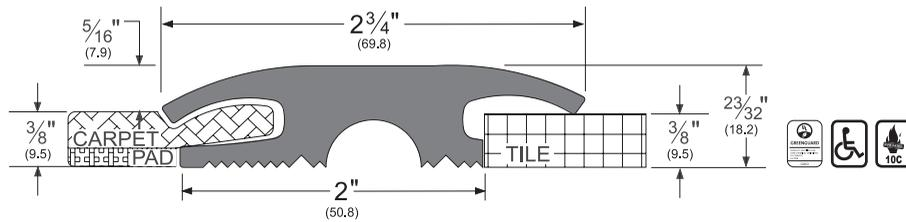

EV2326_

AVAILABLE COLORS: **BL, D**
 AVAILABLE LENGTHS: **36", 48", 73"**
 Serves as a transition where two pieces of tile meet beneath an interior door

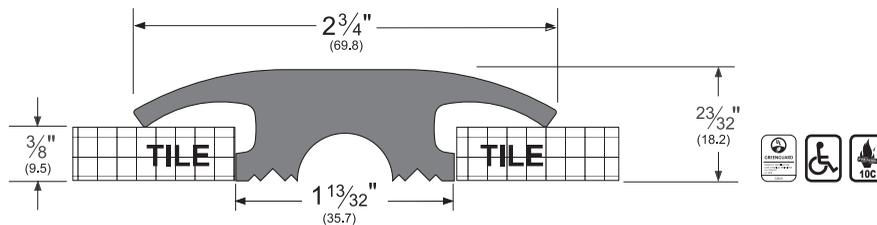

EV2320_

AVAILABLE COLOR: **BL**
 AVAILABLE LENGTHS: **36", 48", 73"**
 Serves as a transition where carpet meets concrete beneath an interior or exterior door

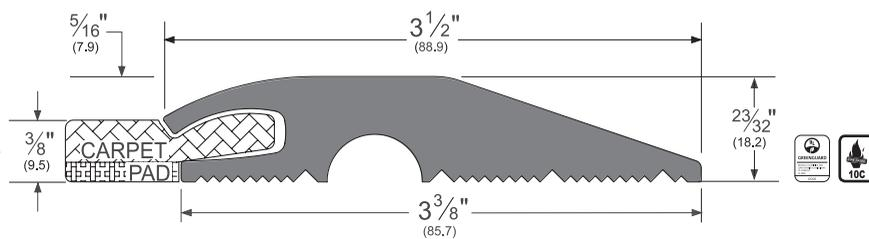

EV2322_

AVAILABLE COLOR: **BL**
 AVAILABLE LENGTHS: **36", 48", 73"**
 Serves as a transition where carpet meets 1/8" tile beneath an interior door

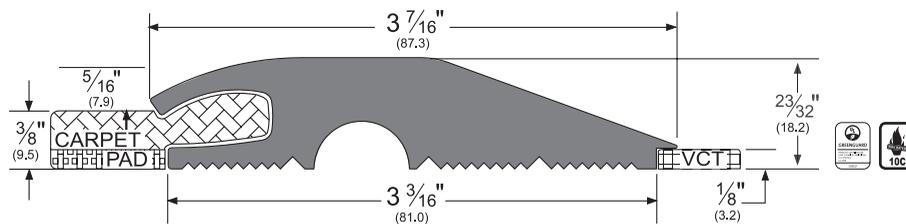

NOTE: Products shown in this section may not be drawn to scale.

AVAILABLE FINISHES FOR PRODUCTS SHOWN ON THIS PAGE
BL (Black) **D** (Dark Brown)



Experience a safer and more open world

ADJUSTABLE-WIDTH ECO-V™ THRESHOLD

- The adjustable-width threshold is designed for installations where the widths of the transition beneath a door may need to change, without completely disassembling and reinstalling the threshold
- The adjustable-width threshold consists of two Eco-V™ end pieces and one Eco-V™ adjustable center section
- Center section (**EV2321** below) can easily be cut to size with a standard razor knife

ADJ232V8_

AVAILABLE COLOR: **BL, D**
 AVAILABLE LENGTHS: **36", 48"**

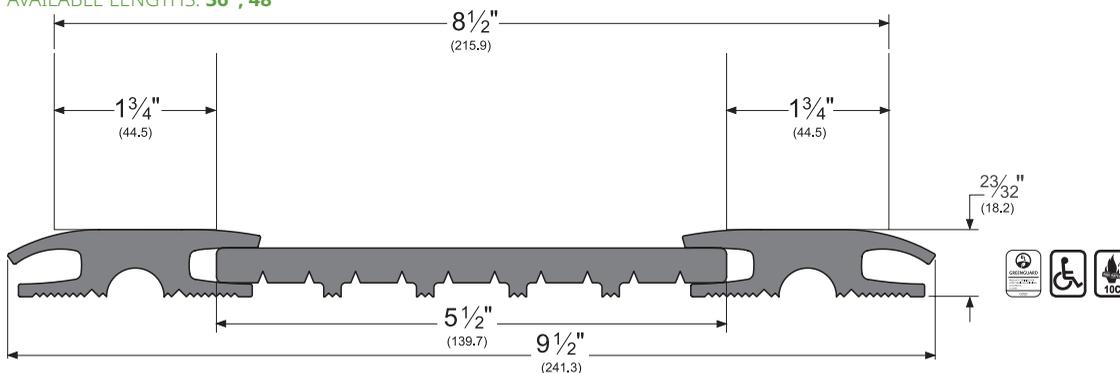

ADJ232V14_

AVAILABLE COLOR: **BL, D**
 AVAILABLE LENGTHS: **36", 48"**

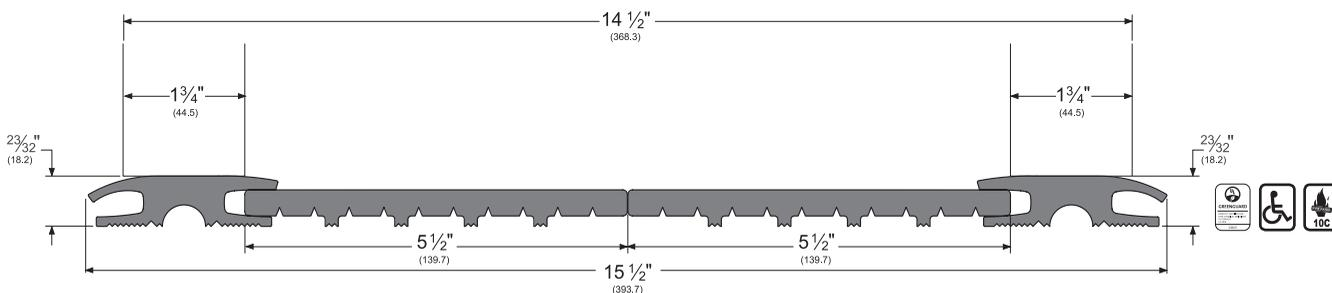

ADJ232x2325V8_

AVAILABLE COLOR: **BL, D**
 AVAILABLE LENGTHS: **36", 48"**

For carpet to tile applications; other combinations available

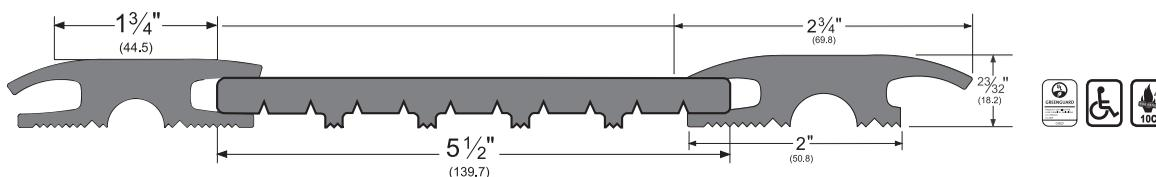

NOTE: Products shown in this section may not be drawn to scale.

AVAILABLE FINISHES FOR PRODUCTS SHOWN ON THIS PAGE

BL (Black) **D** (Dark Brown)

800-824-3018 | www.pemko.com

Check the web site for the up-to-date catalog

Copyright © 2015-2024, ASSA ABLOY Accessories and Door Controls Group, Inc., an ASSA ABLOY Group company. All rights reserved. Reproduction in whole or in part without the express written permission of ASSA ABLOY Accessories and Door Controls Group, Inc. is prohibited.



Experience a safer and more open world

STAINLESS STEEL SLIDING TRACK HARDWARE SYSTEM

W60 SERIES FOR WOOD DOORS

For Sliding Panels up to 176 lbs.

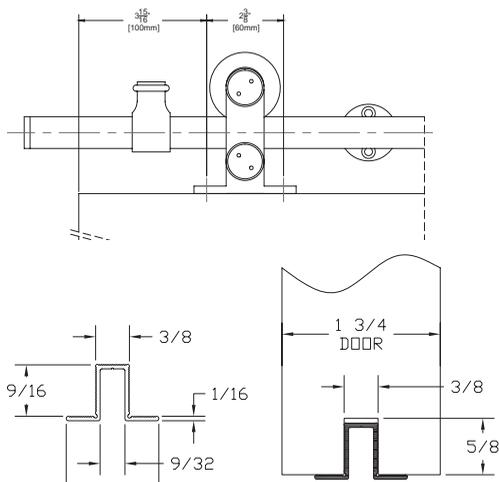
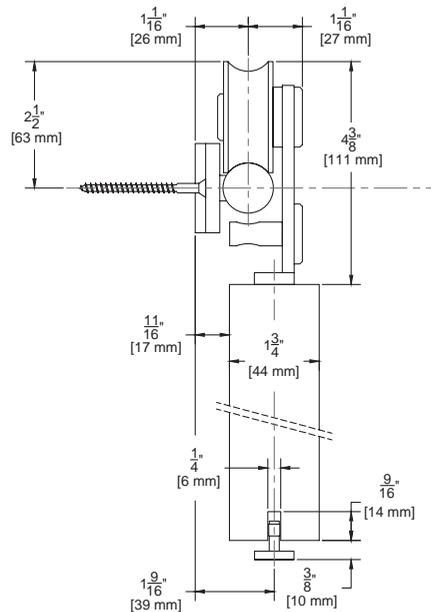
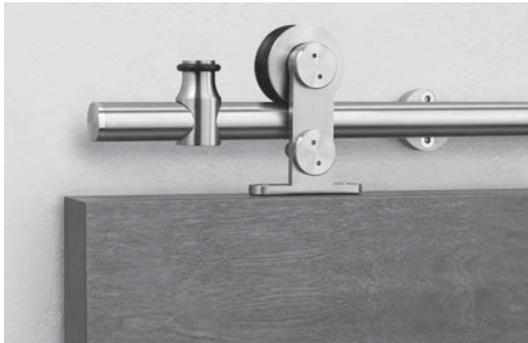

NOTE: Alternate route dimension when using optional EPD3BL

Configurations:

- Single
- Bi-parting

Installations:

- Side Wall Mount (only)

Features:

- Made of 304 stainless steel
- Nylon coated stainless steel wheel for smooth operation
- 176 lb. panel capacity
- 5 year warranty
- Meets ADA push force requirements

Finishes:

- Brushed Stainless Steel (W60)
- Black Powder Coated Stainless Steel (W60D)
- Polished Stainless Steel (W60P)

W60 Kits Include:

- 1 ea **BAR/** Stainless Steel Track
- **BRACKET2** Stainless Steel Wall Brackets
- 2 ea **62** Stainless Steel Hangers
- 1 ea **102SS-KIT** Stainless Steel Guide
- 2 ea **STOP2** Stainless Steel Stops Mounting Hardware

NOTE: If ordering individual parts in the optional Black Powder Coat, Polished finishes be sure to include a prefix "D" for Black Powder Coat, or "P" for Polished Stainless

Standard Kit Sizes			
PART NUMBER	MATERIAL	TRACK LENGTH	DOOR WIDTH
W60/6	304 Stainless Steel	78 ³ / ₄ "	36"
W60/8	304 Stainless Steel	98 ⁷ / ₁₆ "	48"
W60D/6	Black Powder Coated Stainless Steel	78 ³ / ₄ "	36"
W60D/8	Black Powder Coated Stainless Steel	98 ⁷ / ₁₆ "	48"
W60P/6	304 Polished Stainless Steel	78 ³ / ₄ "	36"
W60P/8	304 Polished Stainless Steel	98 ⁷ / ₁₆ "	48"

Custom lengths are available. Please contact the factory to order.

Options:

- Hardware Pack (One Door) **W60_H/PACK**
- Mortise Guides **102N**
- Polypropylene Guide Rail **EPD3BL** For Use With 102N
- 5/8" Spacer **BLD-SPACER-58** Pack of 5 5/8" Spacer Recommended for use with 5/8" Gypsum Board When Mounting Track Directly to Gypsum Board



Experience a safer and more open world

CASCADING SLIDING DOOR SYSTEM

For Sliding Panels up to 200 lbs. each.



Note: All doors must be of equal width. Minimum overlap between doors is 2".

Cased Opening

NOTE: Aluminum "T" Guide **102PB** Shown Under Options Must be Ordered Separately for Fixed Panel in Cased Opening Application



Pocket

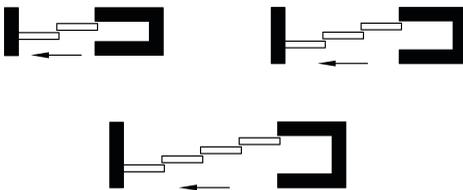

Side Wall Mount

NOTE: Side Wall track Brackets Shown Under Options Must be Ordered Separately for Side Wall Mount Openings



Configurations:

- Bi-part Telescoping
- Single Direction Telescoping

Features:

- Opening and closing of lead door results in the trailing doors to follow because of interlocking hardware at door top edges
- Easy to install with self aligning components on 1 3/4" and 1 3/8" thick doors
- Telescoping panels glide along the track
- Solid steel catches with rubber bumpers ensure durable yet quiet operation
- 200 lb. per door weight capacity
- 5 year warranty

Cascading Kit Includes:

CAS-05 Catches - Mechanical Catch system - 2 Per Door

601H - Track Stops - 2 Per Door

H222R1 - Hangers - 2 Per Door

DBG-02R1 - Door Bottom Guides - 1 Per Door

TELS-23 - End Plates - 2 Per Door

2802C - Single Extrusion - Dual Track

280C - Single Extrusion - Single Track

C1076-TC - Track Connector for CAS200A-4/_ Kits

EPD3-BL - Polypropylene Guide Rails - 1 Per Door

WRENCH14 - 1 Hanger Wrench Hardware Fasteners

Cascading System Kits

PART NUMBER	TRACK LENGTH	# OF DOORS	INSTALLATION
CAS200A-2/6	6'	2	Pocket Side Wall
CAS200A-2/8	8'	2	
CAS200A-2/10	10'	2	
CAS200A-2/12	12'	2	
CAS200A-3/8	8'	3	Pocket Cased Opening Side Wall
CAS200A-3/10	10'	3	
CAS200A-3/12	12'	3	
CAS200A-3/16	16'	3	
CAS200A-4/8	8'	4	Pocket Cased Opening
CAS200A-4/10	10'	4	
CAS200A-4/12	12'	4	
CAS200A-4/16	16'	4	

For special number of doors and for dark bronze track, please contact Technical Support for more information

Options:

Lock Kit	SIM150-LOCKKIT includes lock with edge pull and cup pull
Bolt Kit	SIM150-BOLTKIT includes surface bolt, dust-proof strike, cup pull, and edge pull
Fascia	F134C Snap-on Fascia
Splice Kit	C1076-2SPLKIT for use with Bi-Parting systems and 2802C Track C1076-3SPLKIT for use with Bi-Parting systems and 2803C Track
Back Stop	TELS-25 for use with pocket systems when no access to in track stops in pocket
Aluminium "T" Guide	102PB for use with fixed panel in cased opening applications
Side Wall Track Bracket	2812KIT for use with 2802C Track (1 for every 12" of track) 2813KIT for use with 2803C Track (1 for every 12" of track)
Side Wall Joining Bracket	2813-5KIT for use with Side Wall Bi-Parting systems and 2803C Track

PEMKO
ASSA ABLOY

Experience a safer
and more open world

800-824-3018 | www.pemko.com

Check the web site for the up-to-date catalog

Copyright © 2015-2024, ASSA ABLOY Accessories and Door Controls Group, Inc., an ASSA ABLOY Group company. All rights reserved. Reproduction in whole or in part without the express written permission of ASSA ABLOY Accessories and Door Controls Group, Inc. is prohibited.

SHS80 SERIES

For Sliding Panels up to 200 lbs.

Overhead Mount

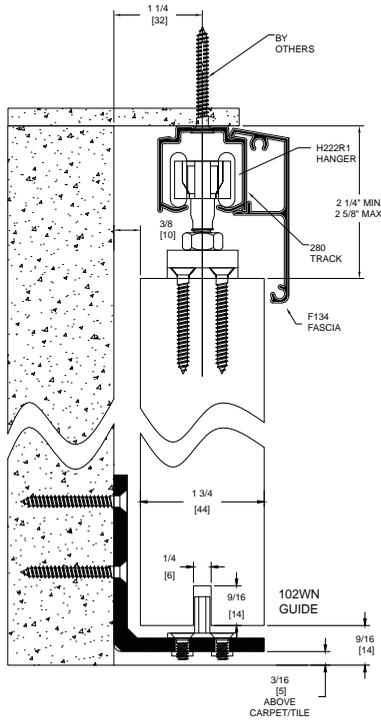

Side Wall Mount

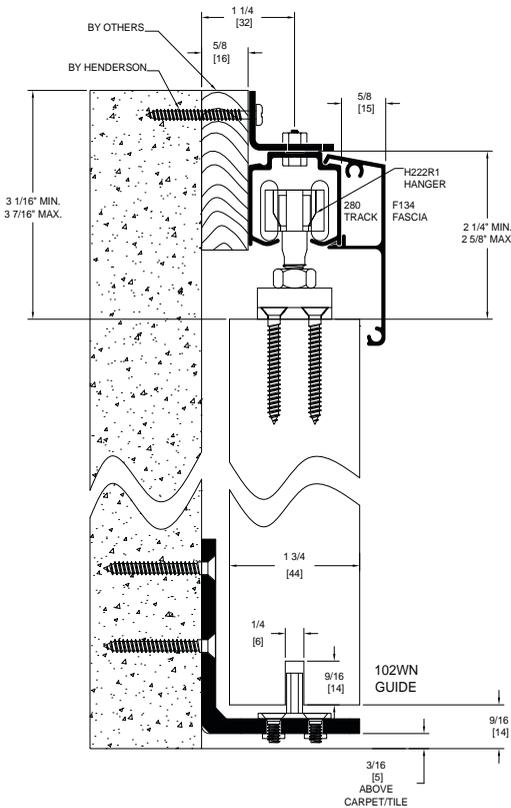

Configurations:

- Single
- Bi-parting

Installations:

- Overhead Mount
- Side Wall Mount

Features:

- Hanger body is made of nickel plated zinc alloy for durability and long life
- Steel ball bearing wheels coated in nylon for smooth operation
- 200 lb. panel capacity
- Optional Soft Close
- 5 year warranty
- Meets ADA push force requirements

SHS80 Kits Include:

- 1 ea **280C** Clear Anodized Aluminum Track
- 2 ea **H222R1** - Nickel Plated Zinc Alloy Body
- 2 ea **601H** Nylon In-Track Clip Stop
- 1 ea **102WN** White Nylon Mortise Guide on Zinc Plated Steel "L" Metal

Standard Kit Sizes			
PART NUMBER	MATERIAL	TRACK LENGTH	DOOR WIDTH
SHS80/6	Aluminum	72"	36"
SHS80/8	Aluminum	96"	48"

Options:

- Fascia **F134C** clear anodized aluminum fascia **F134D** dark bronze anodized fascia
- Side Wall Track Brackets **PC2815** available as 5 pack only, PC2815 pack of 5 281 zinc plated side wall bracket. NOTE: Need one at each end and no more than 2 feet in-between. Fasteners included.
- Track **280D** dark bronze anodized track
- End Plate Kit **K134EP** (use with F134C and 280C only)
- Bottom Channel **94A**
- Roller Guide **106R/94**
- Threshold **971A**
- Side Wall Mount **SHS80/PACK**
- Extra Hardware Pack **102N**
- Mortise Floor Guide **EPD3BL** for use with 102N or 102WN
- Polypropylene Guide Rail **Soft Close** available. See page 269-271 for more information.

Alternate Route for EPD3BL

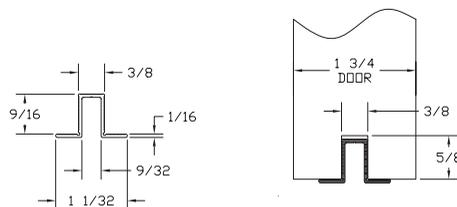

Experience a safer and more open world

800-824-3018 | www.pemko.com
Check the web site for the up-to-date catalog

Copyright © 2015-2024, ASSA ABLOY Accessories and Door Controls Group, Inc., an ASSA ABLOY Group company. All rights reserved. Reproduction in whole or in part without the express written permission of ASSA ABLOY Accessories and Door Controls Group, Inc. is prohibited.

BYPASS TRACK SERIES

For Bypass Panels up to 200 lbs.

1 3/4" Thick Doors Side Wall Mount

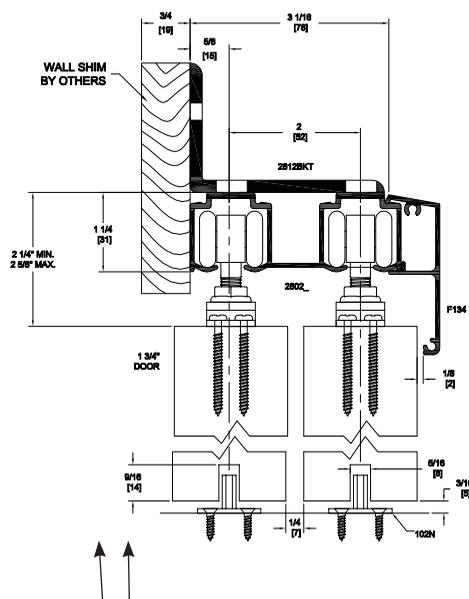

NOTE: Route door 9/16" deep by 1/4" wide to receive 102N Guide.

1 3/4" Thick Doors Overhead Mount

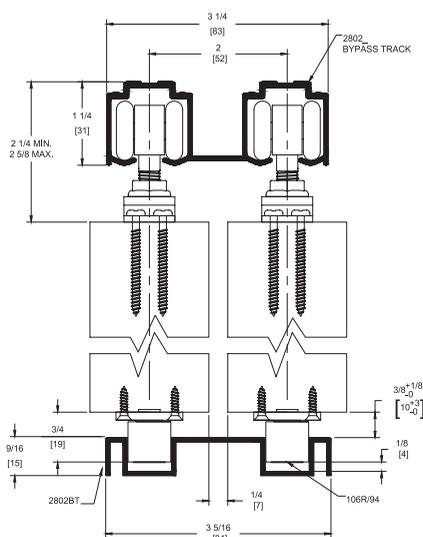

* Side Wall mounting: use one (1) 2812KIT at each end of track and 24" on center

AVAILABLE FINISHES FOR PRODUCTS SHOWN ON THIS PAGE

A (Mill Finish Aluminum) C (Clear Anodized)
800-824-3018 | www.pemko.com

Check the web site for the up-to-date catalog

Copyright © 2015-2024, ASSA ABLOY Accessories and Door Controls Group, Inc., an ASSA ABLOY Group company. All rights reserved.
Reproduction in whole or in part without the express written permission of ASSA ABLOY Accessories and Door Controls Group, Inc. is prohibited.

Configurations:

- For Bypass Doors

Features:

- Fits 1 3/8" and 1 3/4" doors
- Hanger body is made of nickel plated zinc alloy for durability and long life
- Steel ball bearing wheels coated in nylon for smooth operation
- 200 lb. panel capacity
- Load capacity 200 lbs. per door panel (2 hangers)
- Extruded aluminum track
- Optional Soft Close
- 5 year warranty
- Meets ADA push force requirements

HBP200A Kits Include:

- 1 ea **2802C** Clear Anodized Aluminum Track
- 4 ea **H222R1** Hangers
- 2 ea **102N** White Nylon Mortise Guide
- 4 ea **TELS-14KIT** In Track Stops
- 1 ea Adjusting Wrench and Mounting Hardware

Standard Kit Sizes

PART NUMBER	TRACK LENGTH	DOOR WIDTH
HBP200A/4	48"	2 @ 26" Min*
HBP200A/5'4	64"	2 @ 34" Min*
HBP200A/6	72"	2 @ 38" Min*
HBP200A/7	84"	2 @ 44" Min*
HBP200A/8	96"	2 @ 50" Min*
HBP200A/10	120"	2 @ 62" Min*
HBP200A/12	144"	2 @ 74" Min*

*Minimum door overlap is 2".

Options:

- Hardware Kit **H200PACK**
- Mounting Bracket **2812KIT**
- Track **2802D** dark bronze anodized track
- Track Stop (bumper) **287R1-KIT**
- Bottom Channel **94A**
- Fascia, Snap-On **F134C** clear anodized aluminum fascia. **F134D** dark bronze anodized aluminum fascia
- Roller Guide **106R/94**
- Dual Guide Channel **2802BT**
- Polypropylene Guide Rail **EPD3BL** for use with 102N
- Soft Close available. See page 269-271 for more information.



Experience a safer
and more open world



Experience a safer
and more open world

PEMKO ACOUSTIC PRODUCTS

CONTENTS:

Basic Acoustic Information	202
Acoustic Seal Sets	204
Acoustic Thresholds	205
Saddle Thresholds	206
Automatic Door Bottoms - Acoustic	207
Door Shoes	207
Acoustic Adhesive Corner Pads	207
Standard Perimeter Gasketing	208
SiliconSeal Adhesive-Backed Gasketing	208

INDEX:

PRODUCT	PAGE	PRODUCT	PAGE	PRODUCT	PAGE
151	206	2006STC_	205	S44	208
154	206	2008	205	S442	208
175	206	2009	205	S773	208
303	208	2212	207	STC411	207
312	208	3692	207	STC4131	207
315	208	ACP112_	207		
1547	206	PEMKOSTCSET	204		

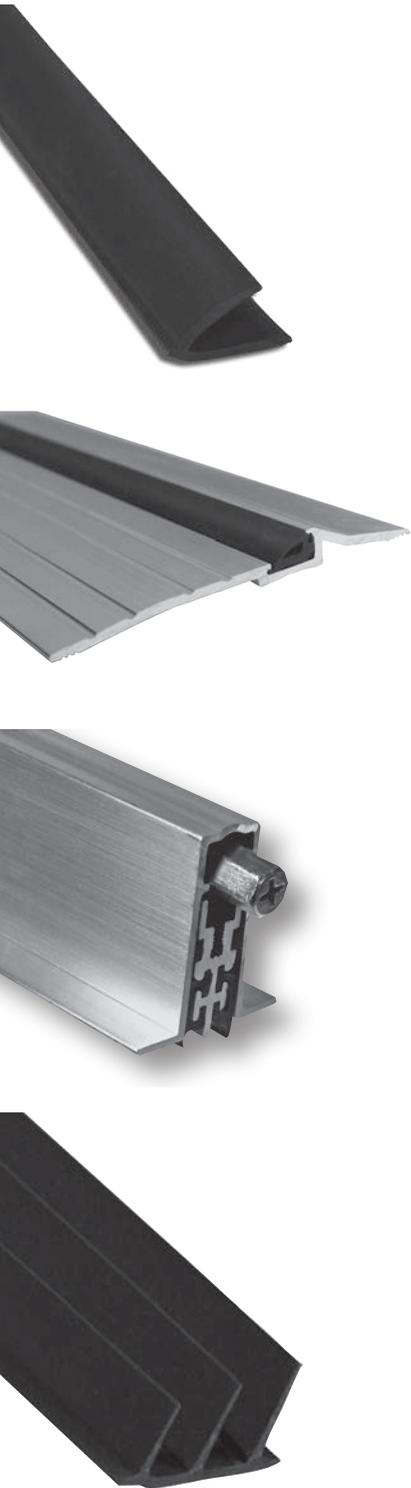

The Impact of Sound

Everyday our ears are met with a barrage of sounds. Sounds can be pleasant, like music or laughter. But they can also be disruptive, like construction or traffic, or even just the people in the cubicle next door. At a certain point sound becomes noise and we look for ways to control it. Sound control is especially important in classrooms, hospitals, hotels and offices, as it impacts our ability to learn, heal, sleep and think. The U.S. Green Building Council recognizes the importance of acoustical control by including LEED Indoor Environment Quality (IEQ) credits for acoustics.

Description of Sound

Sound can be described as vibrations in the air moving in waves. The rate of sound vibrations measured in cycles per second is called frequency and is measured in hertz (Hz). Sound pressure levels are measured in decibels (dB). For a list of common noises and their related decibel level, see the chart on the right.

Sound Level dB		
0	Threshold of hearing	Inaudible
20	Very rural environment	Extremely quiet
30	Quiet home	Faint
40	Quiet office	Distant sounds audible
50	Background conversation	Moderate
60	Radio/Television in home	Moderate
70	Highway noise	Moderately loud
80	Background factory noise	Loud
90	Noisy factory	Very loud
105	Elevated train	Deafening
120	Bass drum at 3'	Physical pain
130	Jet aircraft at 100'	Physical pain

Basic Acoustics

Sound transmission reduction relies on two main principles:

Sound Absorption - Removing sound energy from within a room by using materials such as acoustic tiles or open cell foam to soak up sound.

Sound Insulation - Preventing the transmission of sound waves by introducing a barrier. Examples include brick, concrete, metal, heavy doors, etc.

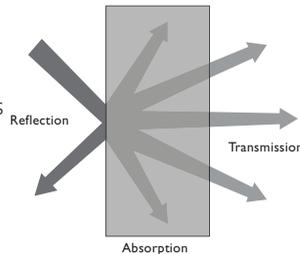

Sound waves will travel the path of least resistance. A high performing door will not compensate for less performing materials in the walls around it.

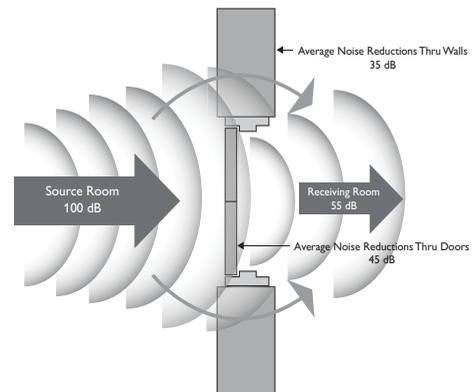

In order to reduce the transmission of sound, materials are added between the source room and the receiving room. The resulting change in decibel level is the sound transmission loss and is given a Sound Transmission Class (STC) rating.

The higher the rating number, the lower the transmission of sound. The STC rating is roughly the decibel reduction a partition can provide. For instance, if a 100 dB noise is reduced to 55 dB, that product roughly has a STC 45 rating.



Experience a safer and more open world

Sound Flanking

Flanking is the leakage of airborne sound around a door opening through any available gap. Flanking between the door leaf and the surrounding frame is reduced by the use of seals.

Optimum sound attenuation performance is likely achieved using a four sided frame with a sill made to the same detail as the head and the seals set in a single plane. If a full four sided frame is not an option, then alternative threshold sealing options should be made such as automatic door bottoms, door shoes and/or thresholds.

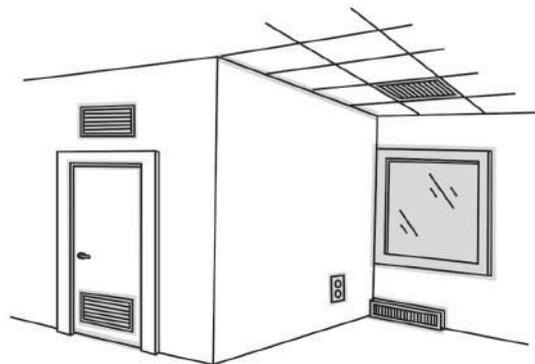

Active STC Rating	Level Of Speech Heard
STC-30	Loud speech understood
STC-35	Loud speech heard but not understood
STC-40	Loud speech audible as a murmur
STC-45	Some loud speech barely audible
STC-48	Hearing strained to hear loud speech
STC-50	Loud speech not audible

STC Ratings

Acoustic Door Testing is done on “sealed-in-place” (fully caulked) doors for door STC ratings, as well as on assemblies (with gasketing and door bottoms) for operable STC ratings. Operable STC ratings are always equal to or lower than the sealed-in-place ratings. The best performance rating on the operable test is a 'zero drop' in the assembly's STC rating. For example, a door with a STC 45 rating can only achieve an operable STC of 45 at its very best; it can never achieve a STC 50.

Also, since sound waves travel the path of least resistance, a high performing door will not compensate for elements like improperly installed seals around doors, the lack of a threshold under the door, a non-insulated frame, louvered doors, or poor seals at the wall/ceiling/floor/mullion connections.

When STC ratings are determined, normal human speech and hearing are used. In most cases the level of reduction does not totally eliminate but rather muffles the sound to an unintelligible level. The chart shown on the left compares the level of speech that would be heard through a door system with the indicated operable STC rating.

Look for Pemko products with this symbol:



Tested To: ASTM E 90-2009

Products indicated by this symbol have been acoustically tested in accordance with ASTM E90 - Standard Test Method for Laboratory Measurement of Airborne Sound Transmission Loss of Building Partitions and Elements.

Need STC Rated Doors?

Pemko Acoustic Seal Sets are an important part of an overall acoustic solution. ASSA ABLOY Group brands can provide the other elements of the solution including STC Rated Doors, STC Rated Frames and complete STC Rated Assemblies.

For more information please see:

CECO DOORS: www.cecodoor.com
 CURRIES: www.curries.com

Acoustic Seal Sets

Pemko acoustic components are available in their appropriate sets. These product combinations are lab tested and have known decibel drops when used with sound-rated doors. Each kit includes gasketing, a door bottom or threshold, and a complete set of installation instructions. Installation instructions show the proper installation location for each component for optimal performance.

HOW TO:

1. Locate the Sealed-In-Place (inoperable) rating for your door.
2. Determine the maximum allowable drop for your opening (i.e. -1 db). Note: the numbers are represented as negative numbers as they will decrease your inoperable rating by the number shown (i.e. 45 using a -1 kit will decrease the inoperable rating from 45 to an operable of 44)
3. Find a number in the column below your door's inoperable rating that will keep your opening in the allowable range.
4. Select a kit (or one of the kits given if Alternate Kits are shown), place it on your Purchase Order and add your opening size in inches (i.e. a 3/0 x 7/0 opening will be ordered as a 3684).

Item Number	Sealed-In-Place Door STC Rating				
	58 to 54	53 to 49	48 to 46	45 to 43	<42
PEMKOSTCSET-1A Alternate Kits: 1B, 1C, 1D, 1E		-2	-2	-1	0
PEMKOSTCSET-2C	-3	-2	-2	-1	0
PEMKOSTCSET-2D Alternate Kits: 2A, 2B	-3	-2	-1	-1	0
PEMKOSTCSET-2E	-2	-2	-1	-1	0
PEMKOSTCSET-3A		-2	-1	0	0
PEMKOSTCSET-3D		-2	-1	0	0
PEMKOSTCSET-3E	-2	-2	-1	0	0
PEMKOSTCSET-3B				0	0
PEMKOSTCSET-4A	-3	-2	-1	0	0
PEMKOSTCSET-4B	-3	-2	-1	0	0
PEMKOSTCSET-4D	-3	-2	-1	0	0
PEMKOSTCSET-4E	-2	-2	-1	0	0

NOTE: A seal set cannot increase the sealed-in-place rating; a zero drop is the best performance any seal set can provide.

Item Number	Gasketing	Door Bottom	Threshold	Corner Pad
PEMKOSTCSET-1A	S773BL (Single Row) and S44BL (Single Row)	STC411APK		ACP112BL
PEMKOSTCSET-1B	S44BL (Two Rows)	STC411APK		ACP112BL
PEMKOSTCSET-1C	S442BL (Single Row) and S44BL (Single Row)	STC411APK		ACP112BL
PEMKOSTCSET-1D	303AS and S44BL (Single Row)	STC411APK		ACP112BL
PEMKOSTCSET-1E	312CR and S44BL (Single Row)	STC411APK		ACP112BL
PEMKOSTCSET-2A	S773BL (Single Row) and S44BL (Single Row)		2008APK	
PEMKOSTCSET-2B	S44BL (Two Rows)		2008APK	
PEMKOSTCSET-2C	S442BL (Single Row) and S44BL (Single Row)		2008APK	
PEMKOSTCSET-2D	303AS and S44BL (Single Row)		2008APK	
PEMKOSTCSET-2E	312CR and S44BL (Single Row)		2008APK	
PEMKOSTCSET-3A	S773BL (Single Row) and S44BL (Single Row)	3692APK773BL		
PEMKOSTCSET-3B	S44BL (Two Rows)	3692APK773BL		
PEMKOSTCSET-3D	303AS and S44BL (Single Row)	3692APK773BL		
PEMKOSTCSET-3E	312CR and S44BL (Single Row)	3692APK773BL		
PEMKOSTCSET-4A	S773BL (Single Row) and S44BL (Single Row)		2009APK	
PEMKOSTCSET-4B	S44BL (Two Rows)		2009APK	
PEMKOSTCSET-4D	303AS and S44BL (Single Row)		2009APK	
PEMKOSTCSET-4E	312CR and S44BL (Single Row)		2009APK	

NOTE: 2008PK and 2009PK have acoustic equivalency.



Experience a safer
and more open world

800-824-3018 | www.pemko.com
Check the web site for the up-to-date catalog

Copyright © 2015-2024, ASSA ABLOY Accessories and Door Controls Group, Inc., an ASSA ABLOY Group company. All rights reserved. Reproduction in whole or in part without the express written permission of ASSA ABLOY Accessories and Door Controls Group, Inc. is prohibited.

ACOUSTIC THRESHOLDS

- Pemko Acoustic Thresholds are designed to aid with a door's STC rating
- Thresholds will not improve a doors "sealed in-place" STC rating
- Visit www.assaabloydooraccessories.us, for more Acoustic products and additional information

2006STC_

AVAILABLE FINISHES: **10BE, A, BSP, D, WSP**
 REPLACEMENT INSERT: **T5 (BL)**
 ANSI (aluminum): **J36100, J36130**

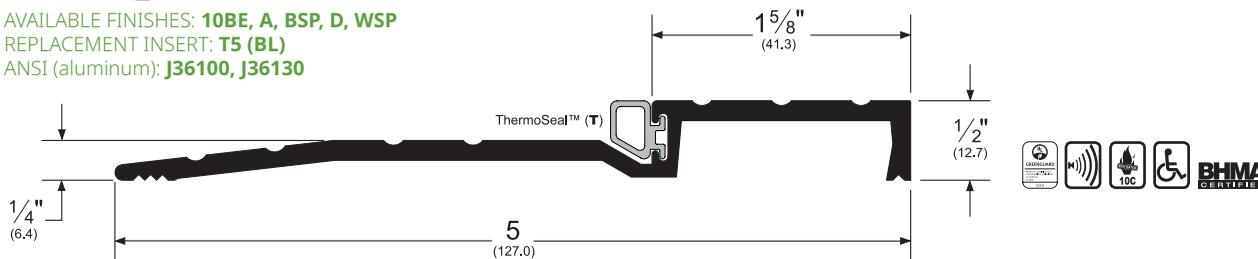

2008_PK

AVAILABLE FINISHES: **10BE, A, BSP, D, WSP**
 REPLACEMENT INSERT: **PK381 (BL)**
 ANSI (aluminum): **J36100, J36130**

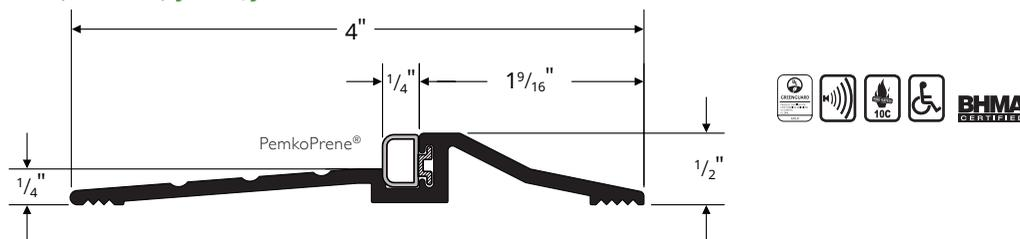

2009_PK

AVAILABLE FINISHES: **10BE, A, BSP, D, WSP**
 REPLACEMENT INSERT: **PK20 (BL)**
 ANSI: **J36100, J36130**
 Allow 3/8" door clearance

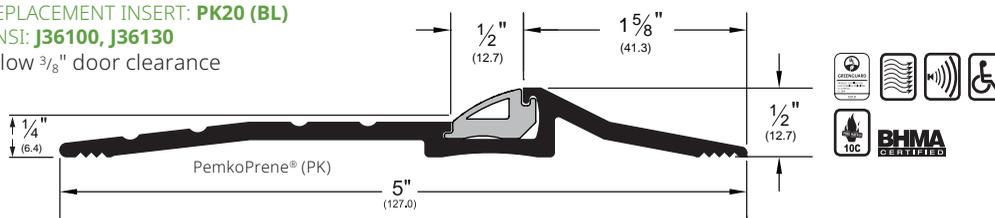

AVAILABLE FINISHES FOR PRODUCTS SHOWN ON THIS PAGE
10BE (Satin Bronze Powder Coated Aluminum) **A** (Mill Finish Aluminum)
BSP (Black Suede Powder Coated Aluminum) **D** (Dark Bronze Anodized)
WSP (White Suede Powder Coated Aluminum)

800-824-3018 | www.pemko.com
 Check the web site for the up-to-date catalog

Copyright © 2015-2024, ASSA ABLOY Accessories and Door Controls Group, Inc., an ASSA ABLOY Group company. All rights reserved.
 Reproduction in whole or in part without the express written permission of ASSA ABLOY Accessories and Door Controls Group, Inc. is prohibited.

PEMKO
ASSA ABLOY

Experience a safer
 and more open world

SADDLE THRESHOLDS

- Use these with Pemko Automatic Door Bottoms to create a smooth, even sealing surface

151_

AVAILABLE FINISHES: **10BE**, **A**, **B**, **BSP**, **D**, **WSP**
 ANSI (aluminum): **J32300**, **J32330**
 ANSI (brass): **J12300**, **J12330**

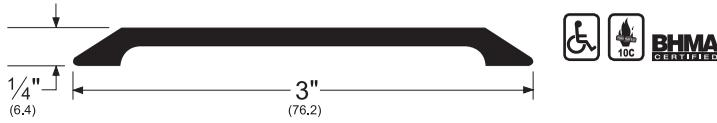

175_

AVAILABLE FINISHES: **10BE**, **A**, **B**, **BSP**, **D**, **WSP**
 ANSI (aluminum): **J32300**, **J32330**
 ANSI (brass): **J12300**, **J12330**

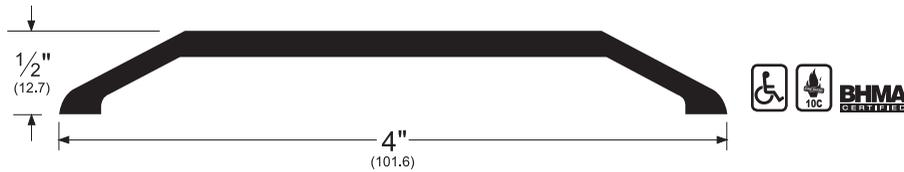

154_

AVAILABLE FINISHES: **10BE**, **A**, **BSP**, **D**, **WSP**
 ANSI (aluminum): **J32300**, **J32330**

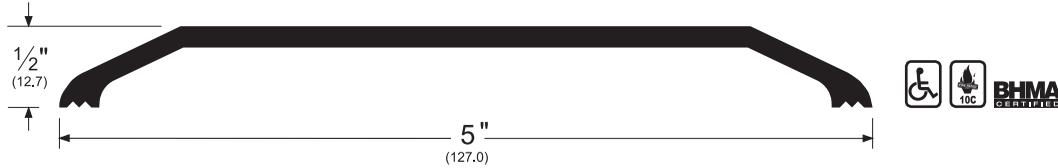

1547_

AVAILABLE FINISHES: **10BE**, **A**, **BSP**, **WSP**
 ANSI (aluminum): **J32300**, **J32330**

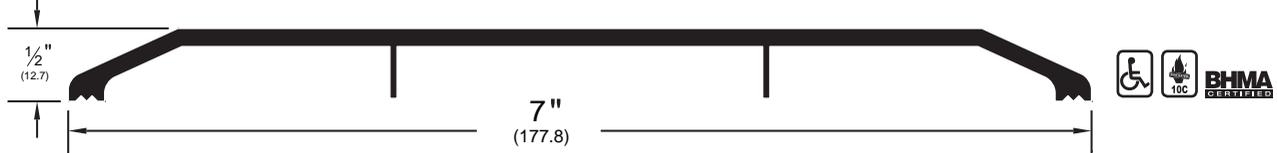

Experience a safer and more open world

AVAILABLE FINISHES FOR PRODUCTS SHOWN ON THIS PAGE
10BE (Satin Bronze Powder Coated Aluminum) **A** (Mill Finish Aluminum)
B (Mill Finish [Brass] Bronze) **BSP** (Black Suede Powder Coated Aluminum)
D (Dark Bronze Anodized) **WSP** (White Suede Powder Coated Aluminum)

800-824-3018 | www.pemko.com
 Check the web site for the up-to-date catalog

Copyright © 2015-2024, ASSA ABLOY Accessories and Door Controls Group, Inc., an ASSA ABLOY Group company. All rights reserved. Reproduction in whole or in part without the express written permission of ASSA ABLOY Accessories and Door Controls Group, Inc. is prohibited.

AUTOMATIC DOOR BOTTOMS - ACOUSTIC

- Non-handed
- Recommended gap under door is 1/2" for optimal acoustic performance max drop is 3/4"
- Internal mechanism allows bar to accommodate slight imperfections in floor materials
- STC411 end plate kit is K435; for doors narrower than 1-3/4", specify end plate kit K411
- STC4131 end plate kit is K4133C for Clear Anodized and K4133D for Dark Bronze Anodized

STC411_PK

AVAILABLE FINISHES: **A**
REPLACEMENT INSERT:
PK4111 (BL)
ANSI: **R3G324, R3G325**

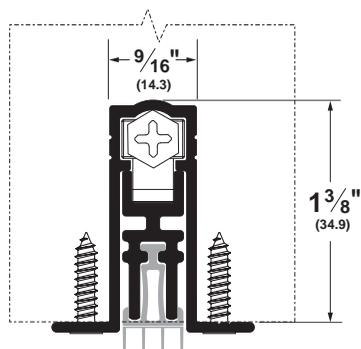

STC4131_PK

AVAILABLE FINISHES: **10BE, BSP, C, D, WSP**
REPLACEMENT INSERT: **PK4111 (BL)**
ANSI: **R3G334, R3G335, R3G344, R3G345**



NOTE:
STC411_PK Automatic Door Bottom is now included in PEMKOSTCSET-1 (A through E). Please see Acoustic Products section for more information.

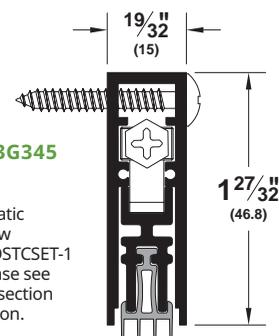

DOOR SHOES

- Slotted holes for easy adjustment
- Provided with stainless steel fasteners
- Use a flat saddle to create a positive sealing surface that ensures maximum acoustic performance

3692_PK773

AVAILABLE FINISH: **A**
AVAILABLE LENGTHS: **36", 48"**
REPLACEMENT INSERT: **PK773 (BL, GR)**
ANSI: **R3G414, R3G415**

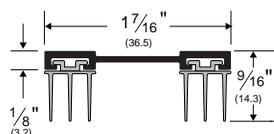

2212_PK773

AVAILABLE FINISHES: **10BE, A, BSP, WSP**
REPLACEMENT INSERT: **PK773 (BL)**
ANSI: **R3G416**

- Combination door shoe and kick plate
- Excellent Acoustic performance

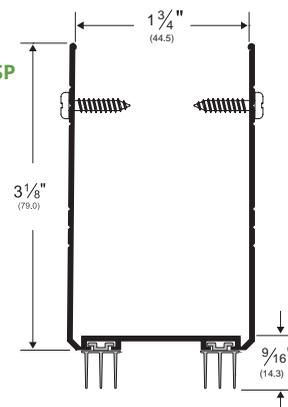

ACOUSTIC ADHESIVE CORNER PADS

- Corner pad with black or white polypropylene pile, with pressure-sensitive adhesive
- Apply to corner of jamb on hinge side to seal against air and light infiltration

ACP112_

AVAILABLE COLORS: **BL, W**

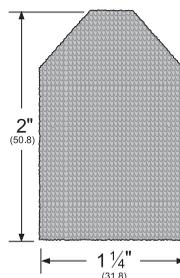

NOTE: Products shown in this section may not be drawn to scale.

AVAILABLE FINISHES FOR PRODUCTS SHOWN ON THIS PAGE
10BE (Satin Bronze Powder Coated Aluminum) **A** (Mill Finish Aluminum)
BSP (Black Suede Powder Coated Aluminum) **C** (Clear Anodized)
D (Dark Bronze Anodized) **WSP** (White Suede Powder Coated Aluminum)
Corner Pads: **BL** (Black) **W** (White)

800-824-3018 | www.pemko.com

Check the web site for the up-to-date catalog

Copyright © 2015-2024, ASSA ABLOY Accessories and Door Controls Group, Inc., an ASSA ABLOY Group company. All rights reserved.
Reproduction in whole or in part without the express written permission of ASSA ABLOY Accessories and Door Controls Group, Inc. is prohibited.

PEMCO
ASSA ABLOY

Experience a safer
and more open world

STANDARD PERIMETER GASKETING

- Rigid jamb weatherstrip shown mounted on openings with $\frac{1}{16}$ " gaps; however, each weatherstrip can seal gaps up to the depth of its seal. Seal depth provided on each illustration (example: the **303** has a $\frac{1}{4}$ " seal; therefore, it can seal up to a $\frac{1}{4}$ " gap)
- Punched on 6" centers with slotted holes for adjustment
- Model 303 is available with self-adhesive two-sided tape (TST) and tek screws (3 slotted holes per part) for easy installation. To obtain this option, add "TST" to the end of the part when ordering (example: **303AVTST**)
- Pemko is continually commissioning tests for acoustic assemblies. More profiles may be tested from this category. Please contact Customer Service if the options here don't suit your application.

303_S

AVAILABLE FINISHES: **10BE, A, BSP, C, D, G, PW, SN, WSP**
 REPLACEMENT INSERT: **S3 (BL, GR, W)**
 ANSI: **R3E164, R3E165**

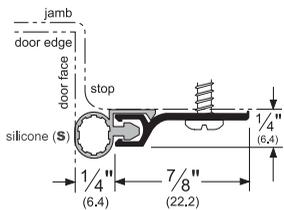

312_R

AVAILABLE FINISHES: **10BE, BSP, C, D, WSP**
 REPLACEMENT INSERT: **ER9BL (BL)**
 ANSI (alum): **R3G164, R3G165**

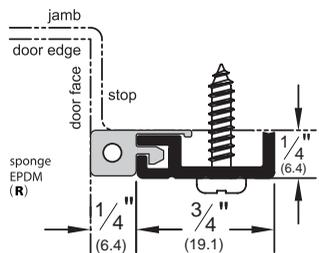

315_R

AVAILABLE FINISHES: **10BE, BSP, C, D, WSP**
 REPLACEMENT INSERT: **ER9BL (BL)**
 ANSI (alum): **R3G164, R3G165**

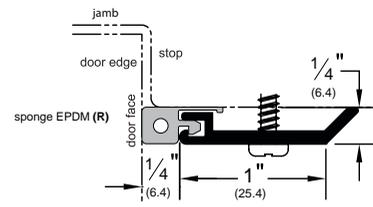

SILICONSEAL ADHESIVE-BACKED GASKETING

- SiliconSeal is extruded from high-temperature silicone; effective between -58°F and 450°F
- Self-extinguishing and non-toxic; unaffected by sunlight, ozone, and ultraviolet rays
- Impervious to fungus and mildew; will not deteriorate under normal exposure
- Meets FAR 25.853 Airworthiness Standards for Compartment Interiors

S44_

AVAILABLE FINISHES: **BL, C, D, GR, W**
 AVAILABLE LENGTHS: **17', 18', 20', 21', 25', 30', 204', 510'**
 ANSI: **ROE154, ROE155**

- Designed for tighter frames
- Demonstrates extremely low closing force
- Seal begins compressing at $\frac{5}{16}$ "; compresses to seal up to a $\frac{1}{16}$ " gap

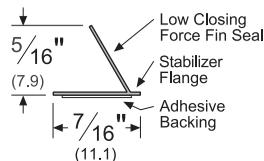

S442_

AVAILABLE FINISHES: **BL, D, W**
 AVAILABLE LENGTHS: **17', 18', 20', 21', 25', 30', 510'**
 ANSI: **ROE154, ROE155**

- Fits flush into corner
- Seal begins compressing at $\frac{5}{16}$ "; compresses to seal up to a $\frac{1}{16}$ " gap in either direction

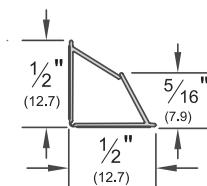

S773_

AVAILABLE FINISHES: **BL, D, GR, W**
 AVAILABLE LENGTHS: **17', 18', 20', 21', 25', 30', 250', 500'**
 ANSI: **ROE154, ROE155**

- Triple-fin design effectively blocks light and sound from infiltrating a room
- Seal begins compressing at $\frac{3}{8}$ "; compresses to seal up to a $\frac{3}{32}$ " gap

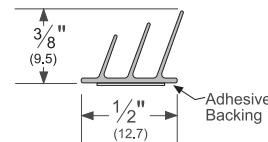

NOTE: Products shown in this section may not be drawn to scale.

AVAILABLE FINISHES FOR PRODUCTS SHOWN ON THIS PAGE

Metal: **10BE** (Satin Bronze Powder Coated Aluminum) **A** (Mill Finish Aluminum)

BSP (Black Suede Powder Coated Aluminum) **D** (Dark Bronze Anodized) **G** (Gold Anodized)

PW (Painted White) **SN** (Satin Nickel Anodized) **WSP** (White Suede Powder Coated Aluminum)

SiliconSeal: **BL** (Black) **C** (Clear) **D** (Dark) **GR** (Gray) **W** (White)

PEMKO
ASSA ABLOY

Experience a safer
 and more open world



CONTENTS:

H180A Series	210
SHS80 Series.....	211
Sliding 200 Series.....	212
Side Wall Track (SWT) System.....	213
Bypass Track Series.....	216
SIM200A Series.....	217
LP200 Series	218
Sirocco Series.....	219
H300S-OH Series.....	220
H300S-SW Series.....	221
H440A-OH Series	222
H440A-SW Series.....	223
TBS250A-OH Series.....	224
TBS250A-SW Series.....	225
H600S-OH Series.....	226
H600S-SW Series.....	227
H800S-OH Series.....	228
H800S-SW Series.....	229
H1100A-OH Series	230
H1100A-SW Series	231
Husky Sliding Glass Series.....	232
Pocket Frame Kit.....	233
Folding 100 Series.....	234
Pacer Interior End Fold Series.....	235
Flexirol Interior End Fold Series.....	236
Stainless Steel Sliding Track Hardware System for Wood Doors	237
Stainless Steel Sliding Track Hardware System for Glass Doors	246
Builders Series Flat Track for Wood Doors	248
Designer Series Flat Track for Wood Doors.....	250
SIM 150 - 2 Door	252
SIM 150 - 3 Door	253
Cascading Door with Sample Configurations	254
SDL Privacy Barn Door Lock.....	255
Options and Accessories.....	256
Privacy Seal Sets.....	256
Soft Close Systems.....	257

INDEX:

PRODUCT	PAGE	PRODUCT	PAGE	PRODUCT	PAGE	PRODUCT	PAGE	PRODUCT	PAGE		
1A/290.....	221	94A.....	234	281.....	232	1075C.....	210	H300S-OH.....	220	PFBS.....	256
1A/290/EC.....	220	94A.....	256	281.....	234	1076.....	254	H300S-SW.....	221	PFCDKIT.....	233
1A/301.....	227	102N.....	210	281.....	256	2802.....	216	H440A-OH.....	222	PFFC-8.....	233
1A/301/EC.....	226	102N.....	220	282HD.....	234	2802.....	254	H440A-SW.....	223	PFHB-1.....	233
1A/550.....	231	102N.....	237	283.....	234	2802BT.....	216	H600S-OH.....	226	PFHB-2.....	233
1AX/290.....	221	102N.....	248	284D.....	232	2802BT.....	256	H600S-SW.....	227	PFHS.....	233
1AX/301.....	227	102N.....	256	287R1-KIT.....	210	2803.....	252	H800S-OH.....	228	PFKIT-4.....	233
1AX/301.....	229	102WA.....	210	287R1-KIT.....	212	2812.....	216	H800S-SW.....	229	PFKIT-8.....	233
1B.....	223	102WA.....	212	287R1-KIT.....	216	2812.....	254	H1100A-OH.....	230	SIM150-BOLTKIT.....	252
1BX.....	223	102WA.....	217	289B.....	234	2812.....	256	H1100A-SW.....	231	SIM150-LOCKKIT.....	252
3A/290.....	220	102WA.....	221	289T.....	234	BAR.....	237	HBP200A.....	216	SDL.....	255
3A/301.....	226	102WA.....	223	290.....	220	BRACKET2.....	237	HF2/100.....	234	SHS80.....	211
3A/301.....	228	102WA.....	229	301.....	226	EPD3.....	210	HF2/100PACK.....	234	SIM100.....	217
3AX/290.....	220	102WA.....	256	403/2.....	235	EPD3.....	216	HF2/100PACK.....	256	SIM150.....	252
3AX/301.....	226	102WN.....	210	550A.....	230	EPD3.....	237	HF4/100.....	234	SIM150-BOLTKIT.....	252
3AX/301.....	228	102WN.....	217	550A.....	236	EPD3.....	248	HH3/290.....	220	SIM150-LOCKKIT.....	252
8-12/SN.....	232	102WN.....	221	556/21.....	236	EPD3.....	252	HH3/301.....	226	SIM200A.....	217
12.....	246	102WN.....	223	556/57.....	230	F134.....	210	K28_SWEP.....	213	SIRLH/SIRRH.....	219
21/550/P.....	236	102WN.....	227	600A.....	222	F134.....	216	K134EP.....	211	SOFT CLOSE.....	257
21BO/4.....	235	102WN.....	229	600A.....	235	F134.....	252	K134EP.....	217	STOP1.....	240
21B/P.....	235	102WN.....	248	601H.....	211	F134.....	256	K134EP.....	256	STOP1.....	247
21N/94.....	235	106HF/94.....	234	601H.....	217	F160C.....	222	K1077_SWEP.....	210	STOP1.....	256
21R/94.....	236	106N/94.....	256	601H.....	232	F160ECP.....	222	LH100.....	218	STOP2.....	237
32.....	247	106R/94.....	210	601H.....	254	F200C.....	223	LP200A.....	218	STOP2.....	239
57A/N.....	228	106R/94.....	220	601H.....	256	F200ECP.....	223	PF2x6KIT.....	233	STOP2.....	245
57A/S.....	226	106R/94.....	256	601P.....	222	FIF2/275A.....	236	PF134 KIT.....	233	TBS250A-OH.....	224
57B.....	222	111.....	243	971A.....	210	G60 to G70.....	246	PF28200A.....	233	TBS250A-SW.....	225
57K/N.....	220	280.....	210	971A.....	217	GLASSGUIDE.....	246	PFAS.....	233	W60 to W100.....	237
62.....	237	280.....	217	971A.....	220	H180A.....	210	PFAS88.....	233		
72.....	240	280.....	234	971A.....	222	H200.....	212	PFAS100.....	233		
82.....	241	280_SWF.....	213	971A.....	226	H200PACK.....	212	PFBG-4.....	233		
89/2N.....	220	280_SWT.....	213	971A.....	228	H200PACK.....	256	PFBG-4.....	256		
92.....	242	280_SWTKIT.....	213	971A.....	230	H222R1.....	210	PFBG-8.....	233		
94A.....	210	281.....	211	971A.....	234	H222R1.....	233	PFBG-8.....	256		
94A.....	220	281.....	217	971A.....	256	H222R1.....	254	PFBS.....	233		

800-824-3018 | www.pemko.com

Check the web site for the up-to-date catalog

Copyright © 2015-2024, ASSA ABLOY Accessories and Door Controls Group, Inc., an ASSA ABLOY Group company. All rights reserved. Reproduction in whole or in part without the express written permission of ASSA ABLOY Accessories and Door Controls Group, Inc. is prohibited.

PEMCO
ASSA ABLOY

Experience a safer
and more open world

H180A SERIES

For Sliding Panels up to 200 lbs.

Overhead Mount

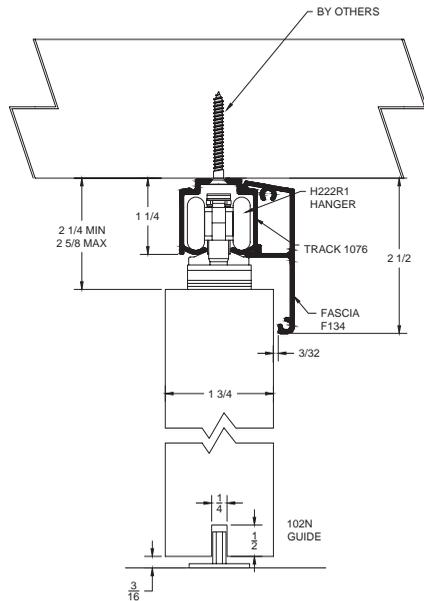

Side Wall Mount

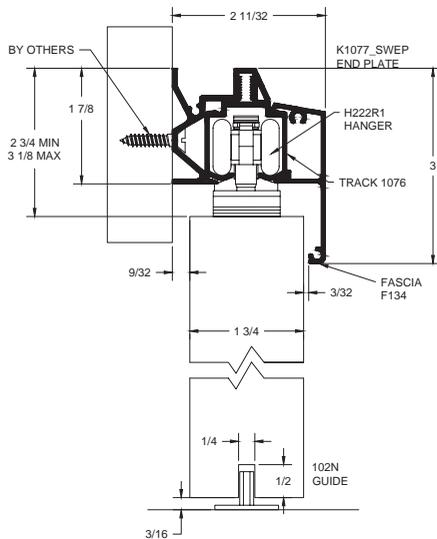

Configurations:

- Single
- Bi-parting

Installations:

- Overhead Mount
- Side Wall Mount

Features:

- Hanger body is made of nickel plated zinc alloy for durability and long life
- Steel ball bearing wheels coated in nylon for smooth operation
- 200 lb. panel capacity
- Optional side wall bracket reduces the amount of wall space needed to mount the track
- Optional Soft Close
- 5 year warranty
- Meets ADA push force requirements

H180A Kits Include:

- 1 ea **280C** Clear Anodized Aluminum Track
- 2 ea **H222R1** - Nickel Plated Zinc Alloy Body
Zinc Alloy Wheels Coated in Nylon
- 2 ea **287R1-KIT** Rubber Bumper In-Track Stop
- 1 ea **102N** White Nylon Mortise Guide

Standard Kit Sizes

PART NUMBER	MATERIAL	TRACK LENGTH	DOOR WIDTH
H180A/6	Aluminum	72"	36"
H180A/8	Aluminum	96"	48"

Options:

Fascia

F134C clear anodized aluminum fascia

Side Wall Track Bracket

F134D dark bronze anodized fascia
1075C clear anodized aluminum bracket- order same length as track

Track

280D dark bronze anodized track

End Plate Kit

K1077C-SWEP (use with F134C fascia and 1075C side wall bracket only)

Bottom Channel

94A

Roller Guide

106R/94

Threshold

971A

Side Wall Mount

102WN (nylon) and **102WA** (steel)

Mortise Guides

Polypropylene Guide Rail

EPD3BL for use with 102N or 102WN

Soft Close available. See pages 269-271 for more information.

Alternate Route for EPD3BL

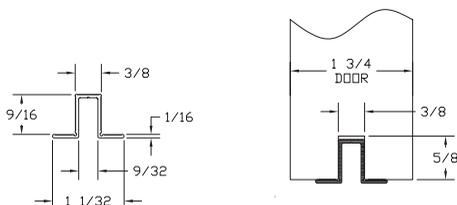

Experience a safer and more open world

SHS80 SERIES

For Sliding Panels up to 200 lbs.

Overhead Mount

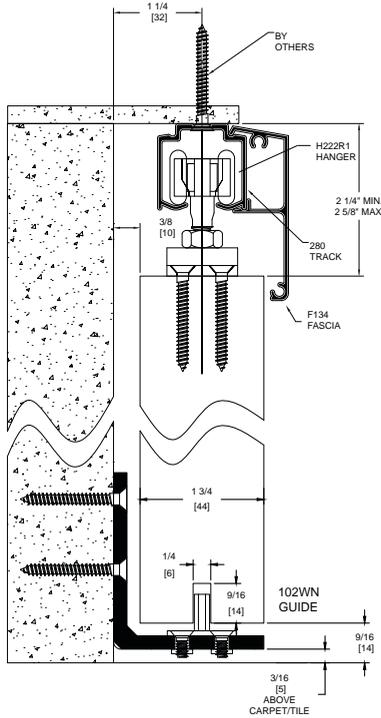

Side Wall Mount

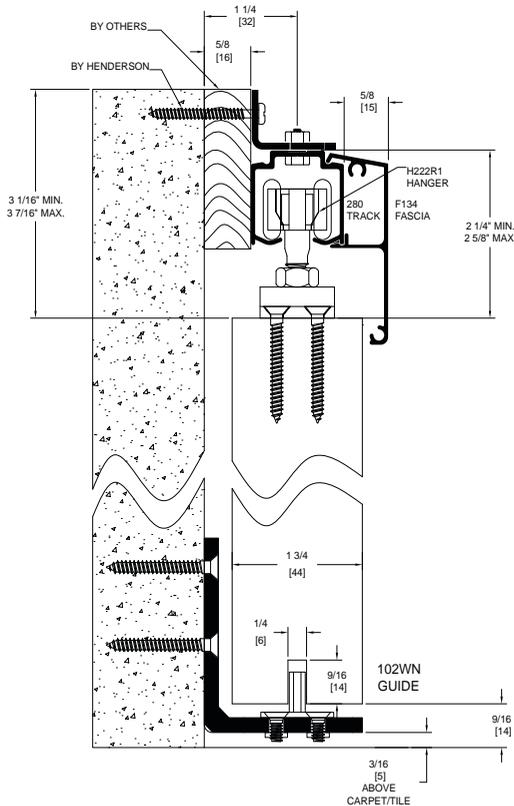

Configurations:

- Single
- Bi-parting

Installations:

- Overhead Mount
- Side Wall Mount

Features:

- Hanger body is made of nickel plated zinc alloy for durability and long life
- Steel ball bearing wheels coated in nylon for smooth operation
- 200 lb. panel capacity
- Optional Soft Close
- 5 year warranty
- Meets ADA push force requirements

SHS80 Kits Include:

- 1 ea **280C** Clear Anodized Aluminum Track
- 2 ea **H222R1** - Nickel Plated Zinc Alloy Body
- 2 ea **601H** Nylon In-Track Clip Stop
- 1 ea **102WN** White Nylon Mortise Guide on Zinc Plated Steel "L" Metal

Standard Kit Sizes

PART NUMBER	MATERIAL	TRACK LENGTH	DOOR WIDTH
SHS80/6	Aluminum	72"	36"
SHS80/8	Aluminum	96"	48"

Options:

Fascia

F134C clear anodized aluminum fascia

Side Wall Track Brackets

F134D dark bronze anodized fascia

PC2815 available as 5 pack only, PC2815 pack of 5 281 zinc plated side wall bracket. NOTE: Need one at each end and no more than 2 feet in-between. Fasteners included.

Track

280D dark bronze anodized track

End Plate Kit

K134EP (use with F134C and 280C only)

Bottom Channel

94A

Roller Guide

106R/94

Threshold

971A

Side Wall Mount

Extra Hardware Pack

SHS80/PACK

Mortise Floor Guide

102N

Polypropylene Guide Rail

EPD3BL for use with 102N or 102WN

Soft Close available. See pages 269-271 for more information.

Alternate Route for EPD3BL

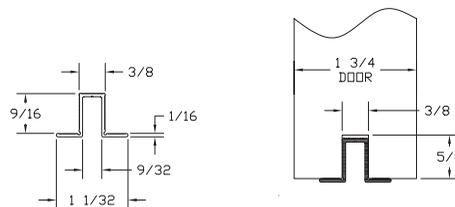

800-824-3018 | www.pemko.com

Check the web site for the up-to-date catalog

Copyright © 2015-2024, ASSA ABLOY Accessories and Door Controls Group, Inc., an ASSA ABLOY Group company. All rights reserved. Reproduction in whole or in part without the express written permission of ASSA ABLOY Accessories and Door Controls Group, Inc. is prohibited.

PEMKO
ASSA ABLOY

Experience a safer
and more open world

SLIDING 200 SERIES

For Sliding Panels up to 200 lbs.
Manufactured by P.C. Henderson

280C Side Wall Mounted

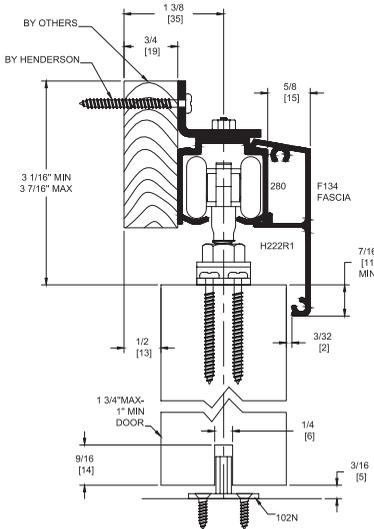

280C Soffit Mounted with Fascia

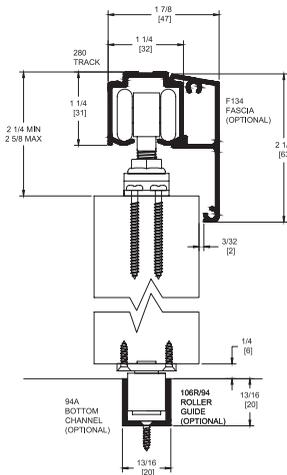

Configurations:

- Single
- Bi-parting

Installations:

- Overhead Mount
- Side Wall Mount

Features:

- Hanger body is made of nickel plated zinc alloy for durability and long life
- Steel ball bearing wheels coated in nylon for smooth operation
- 200 lb. panel capacity
- Galvanized steel track 280
- Clear anodized aluminum track 280C
- Optional Soft Close
- 5 year warranty
- Meets ADA push force requirements

H200A Kits Include:

- 1 ea **280C** Clear Anodized Aluminum Track
- 2 ea **H222R1** Hangers
- 1 ea **102N** Nylon Guide
- 2 ea **TELS-14KIT** Stops
- 1 ea Adjusting Wrench and Mounting Hardware

H200 Kits Include:

- 1 ea **280** Steel Track
- 2 ea **H222R1** Hangers
- 1 ea **102N** Nylon Guide
- 2 ea **TELS-14KIT** Stops
- 1 ea Adjusting Wrench and Mounting Hardware

Standard Kit Sizes

PART NUMBER	MATERIAL	TRACK LENGTH	DOOR WIDTH
H200A/4	Aluminum	48"	24"
H200A/6	Aluminum	72"	36"
H200A/7	Aluminum	84"	42"
H200A/8	Aluminum	96"	48"
H200A/10	Aluminum	120"	60"
H200A/12	Aluminum	144"	72"
H200/6	Steel	72"	36"
H200/8	Steel	96"	48"

Options:

Hardware Kit
Mounting Bracket

Track Stop (bumper)
Bottom Channel
Fascia, Snap-On

Track
Roller Guide
Side Wall Mortise Guide
Threshold
End Plate
Polypropylene Guide Rail
Soft Close available. See pages 269-271 for more information.

H200PACK

PC2815 available as 5 pack only, **PC2815** pack of 5 281 zinc plated side wall bracket
NOTE: Need one at each end and no more than 2 feet in-between. Fasteners included.

287R1-KIT

94A
F134C clear anodized (280C aluminum track only)
F134D dark bronze anodized fascia

280D dark bronze anodized
106R/94

102WA (steel) and **102WN** (nylon)

971A

K134EP (use with F134C and 280C only)

EPD3BL for use with 102N or 102WN



Experience a safer and more open world

SIDE WALL TRACK (SWT) SYSTEM

For Sliding Panels up to 200 lbs.

The Pemko Side Wall Track System has a unique mounting bracket that is extruded with the track. An innovative wall mounted bottom guide assembly allows carpet to be replaced without removing the door.



SWT Kit Side Wall Mounted

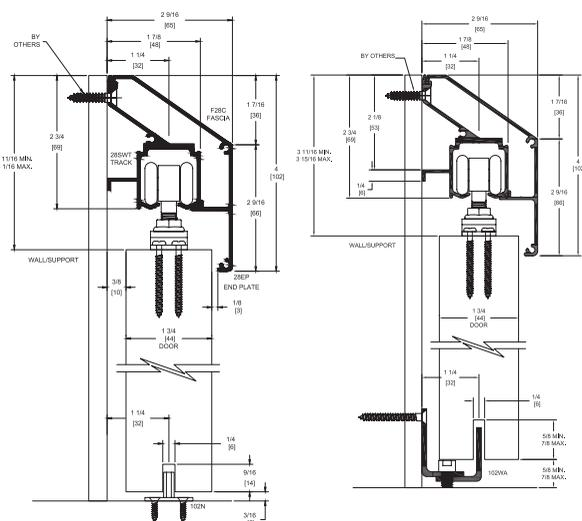

Configurations:

- Single
- Bi-parting

Installations:

- Side Wall Mount

Features:

- Unique mounting bracket extruded into track
- Supports up to 200 lbs. per door
- Quick, easy attachment
- New construction or retrofit
- Optional Soft Close
- 5 year warranty
- Meets ADA push force requirements

280SWT Kits Include:

- 1ea **280_-SWT** Aluminum Track
- 1ea **280_-SWF** Aluminum Fascia
- 1ea **K28_-SWEP** Pair of End Plates
- 2ea **H222R1** Hangers
- 2ea **TELS-14KIT** In Track Stops
- 1ea **102N** White Nylon Mortise Guide
- 1ea **102WA** Wall Mounted Mortise Guide
- 1ea Adjusting Wrench

Standard Kit Sizes

PART NUMBER	TRACK LENGTH	DOOR WIDTH
(Mill Finished Track/Clear Anodized Fascia/End Plates)		
280C-SWTKIT/6	72"	36"
280C-SWTKIT/8	96"	48"
280C-SWTKIT/12*	144"	2 @ 36"
(Dark Bronze Anodized Track/Fascia/End Plates)		
280D-SWTKIT/6	72"	36"
280D-SWTKIT/8	96"	48"
280D-SWTKIT/12*	144"	2 @ 36"

*NOTE: 280_-SWTKIT/12 comes with enough hardware for two doors.

Options:

- Hardware Kit (one door) **H200PACK**
 - Roller Guide **106R/94**
 - Bottom Channel **94A**
 - Nylon Mortise Guide **102WN**
 - Stainless Steel Flush Bolt **FB150SS**
 - Stainless Steel Flush Pull **503SF**
- Soft Close available. See pages 269-271 for more information.

AVAILABLE FINISHES FOR PRODUCTS SHOWN ON THIS PAGE
 A (Mill Finish Aluminum) C (Anodized Aluminum) D (Dark Bronze Anodized)

800-824-3018 | www.pemko.com
 Check the web site for the up-to-date catalog

Copyright © 2015-2024, ASSA ABLOY Accessories and Door Controls Group, Inc., an ASSA ABLOY Group company. All rights reserved.
 Reproduction in whole or in part without the express written permission of ASSA ABLOY Accessories and Door Controls Group, Inc. is prohibited.



Experience a safer
 and more open world

SIDE WALL TRACK SYSTEM WITH RADIUS FASCIA (RF280_-SWTK)

For Sliding Panels up to 200 lbs.

Pemko Side Wall Track Systems have a unique mounting bracket that is extruded with the track. An innovative wall mounted bottom guide assembly allows carpet to be replaced without removing the door.

SWT Kit Side Wall Mounted

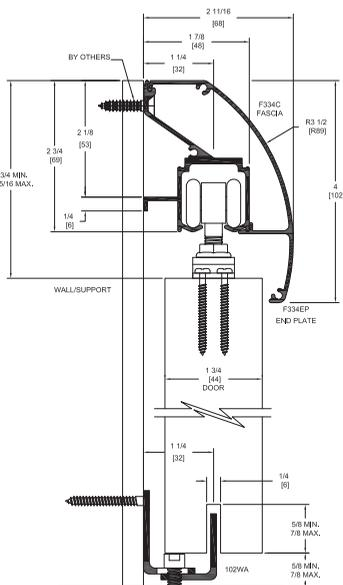
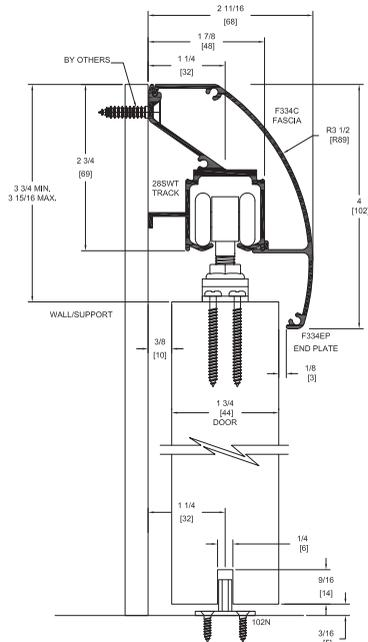

Experience a safer and more open world

Configurations:

- Single
- Bi-parting

Installations:

- Side Wall Mount

Features:

- Unique mounting bracket extruded into track
- Supports up to 200 lbs. per door
- Quick, easy attachment
- New construction or retrofit
- Optional Soft Close
- 5 year warranty
- Meets ADA push force requirements

RF280 SWT Kits Include:

- 1ea **280_-SWT** Aluminum Track
- 1ea **F334_** Aluminum Fascia
- 1ea **KF334_-SWEP** Pair of End Plates
- 2ea **H222R1** Hangers
- 2ea **TELS-14KIT** In Track Stops
- 1ea **102N** White Nylon Mortise Guide
- 1ea **102WA** Wall Mounted Mortise Guide
- 1ea Adjusting Wrench

Standard Kit Sizes		
PART NUMBER	TRACK LENGTH	DOOR WIDTH
(Mill Finished Track/Clear Anodized Fascia/End Plates)		
RF280C-SWTK/6	72"	36"
RF280C-SWTK/8	96"	48"
RF280C-SWTK/12 *	144"	2 @ 36"
(Dark Bronze Anodized Track/Fascia/End Plates)		
RF280D-SWTK/6	72"	36"
RF280D-SWTK/8	96"	48"
RF280D-SWTK/12 *	144"	2 @ 36"

*NOTE: RF280_-SWTK/12 comes with enough hardware for two doors.

Options:

- Hardware Kit (one door) **H200PACK**
- Roller Guide **106R/94**
- Bottom Channel **94A**
- Nylon Mortise Guide **102WN**
- Stainless Steel Flush Bolt **FB150SS**
- Stainless Steel Flush Pull **503SF**
- Soft Close available. See pages 269-271 for more information.

AVAILABLE FINISHES FOR PRODUCTS SHOWN ON THIS PAGE
 A (Mill Finish Aluminum) C (Clear Anodized) D (Dark Bronze Anodized)

800-824-3018 | www.pemko.com
 Check the web site for the up-to-date catalog

Copyright © 2015-2024, ASSA ABLOY Accessories and Door Controls Group, Inc., an ASSA ABLOY Group company. All rights reserved. Reproduction in whole or in part without the express written permission of ASSA ABLOY Accessories and Door Controls Group, Inc. is prohibited.

SIDE WALL TRACK SYSTEM WITH SQUARE FASCIA (SF280_-SWTK)

For Sliding Panels up to 200 lbs.

Pemko Side Wall Track Systems have a unique mounting bracket that is extruded with the track. An innovative wall mounted bottom guide assembly allows carpet to be replaced without removing the door.

SWT Kit Side Wall Mounted

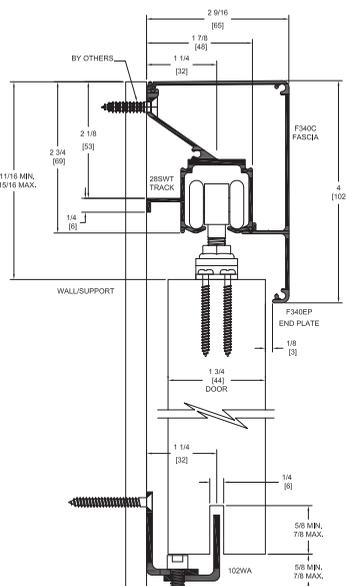
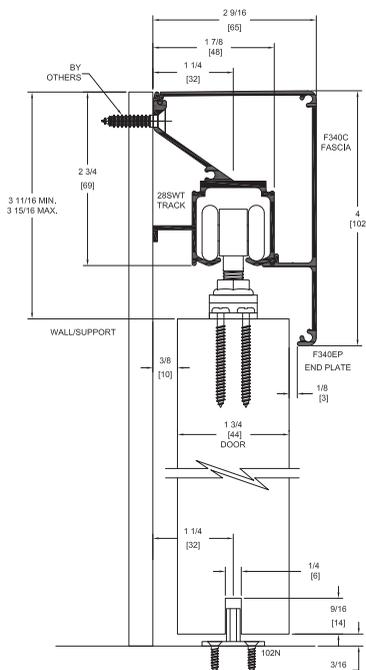

Configurations:

- Single
- Bi-parting

Installations:

- Side Wall Mount

Features:

- Unique mounting bracket extruded into track
- Supports up to 200 lbs. per door
- Quick, easy attachment
- New construction or retrofit
- Optional Soft Close
- 5 year warranty
- Meets ADA push force requirements

SF280SWT Kits Include:

- 1ea **280_-SWT** Aluminum Track
- 1ea **F340_** Aluminum Fascia
- 1ea **KF340_-SWEP** Pair of End Plates
- 2ea **H222R1** Hangers
- 2ea **TELS-14KIT** In Track Stops
- 1ea **102N** White Nylon Mortise Guide
- 1ea **102WA** Wall Mounted Mortise Guide
- 1ea Adjusting Wrench

Standard Kit Sizes		
PART NUMBER	TRACK LENGTH	DOOR WIDTH
(Mill Finished Track/Clear Anodized Fascia/End Plates)		
SF280C-SWTK/6	72"	36"
SF280C-SWTK/8	96"	48"
SF280C-SWTK/12 *	144"	2 @ 36"
(Dark Bronze Anodized Track/Fascia/End Plates)		
SF280D-SWTK/6	72"	36"
SF280D-SWTK/8	96"	48"
SF280D-SWTK/12 *	144"	2 @ 36"

*NOTE: SF280_-SWTK/12 comes with enough hardware for two doors.

Options:

- Hardware Kit (one door) **H200PACK**
 - Roller Guide **106R/94**
 - Bottom Channel **94A**
 - Nylon Mortise Guide **102WN**
 - Stainless Steel Flush Bolt **FB150SS**
 - Stainless Steel Flush Pull **503SF**
- Soft Close available. See pages 269-271 for more information.

AVAILABLE FINISHES FOR PRODUCTS SHOWN ON THIS PAGE
A (Mill Finish Aluminum) C (Clear Anodized) D (Dark Bronze Anodized)

800-824-3018 | www.pemko.com
Check the web site for the up-to-date catalog

Copyright © 2015-2024, ASSA ABLOY Accessories and Door Controls Group, Inc., an ASSA ABLOY Group company. All rights reserved.
Reproduction in whole or in part without the express written permission of ASSA ABLOY Accessories and Door Controls Group, Inc. is prohibited.



Experience a safer
and more open world

BYPASS TRACK SERIES

For Bypass Panels up to 200 lbs.

1 3/4" Thick Doors Side Wall Mount

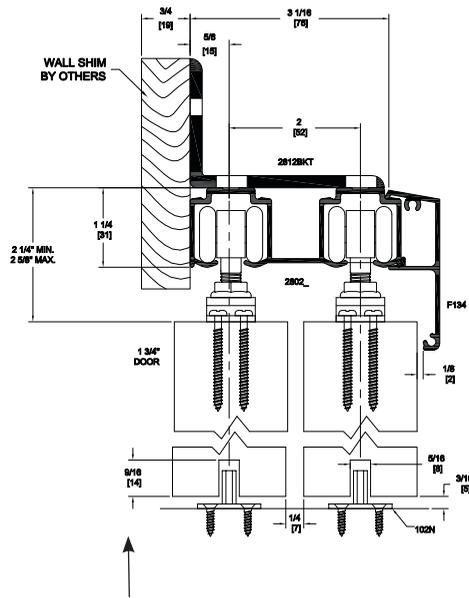

NOTE: Route door 9/16" deep by 1/4" wide to receive 102N Guide.

1 3/4" Thick Doors Overhead Mount

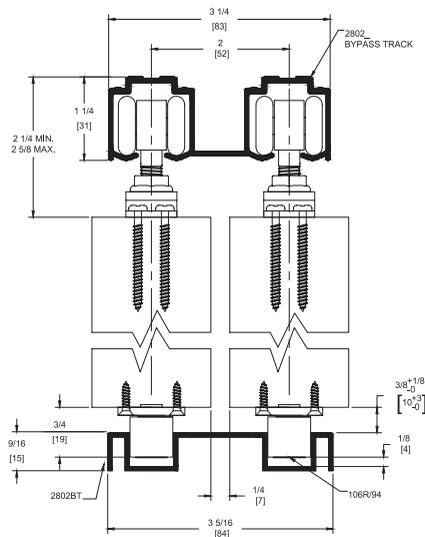

* Side Wall mounting: use one (1) 2812KIT at each end of track and 24" on center

Configurations:

- For Bypass Doors

Features:

- Fits 1 3/8" and 1 3/4" doors
- Hanger body is made of nickel plated zinc alloy for durability and long life
- Steel ball bearing wheels coated in nylon for smooth operation
- 200 lb. panel capacity
- Load capacity 200 lbs. per door panel (2 hangers)
- Extruded aluminum track
- Optional Soft Close
- 5 year warranty
- Meets ADA push force requirements

HBP200A Kits Include:

- 1 ea **2802C** Clear Anodized Aluminum Track
- 4 ea **H222R1** Hangers
- 2 ea **102N** White Nylon Mortise Guide
- 4 ea **TELS-14KIT** In Track Stops
- 1 ea Adjusting Wrench and Mounting Hardware

Standard Kit Sizes

PART NUMBER	TRACK LENGTH	DOOR WIDTH
HBP200A/4	48"	2 @ 26" Min*
HBP200A/5'4	64"	2 @ 34" Min*
HBP200A/6	72"	2 @ 38" Min*
HBP200A/7	84"	2 @ 44" Min*
HBP200A/8	96"	2 @ 50" Min*
HBP200A/10	120"	2 @ 62" Min*
HBP200A/12	144"	2 @ 74" Min*

*Minimum door overlap is 2".

Options:

- Hardware Kit **H200PACK**
 - Mounting Bracket **2812KIT**
 - Track **2802D** dark bronze anodized track
 - Track Stop (bumper) **287R1-KIT**
 - Bottom Channel **94A**
 - Fascia, Snap-On **F134C** clear anodized aluminum fascia.
F134D dark bronze anodized aluminum fascia
 - Roller Guide **106R/94**
 - Dual Guide Channel **2802BT**
 - Polypropylene Guide Rail **EPD3BL** for use with 102N
- Soft Close available. See pages 269-271 for more information.

AVAILABLE FINISHES FOR PRODUCTS SHOWN ON THIS PAGE
A (Mill Finish Aluminum) C (Clear Anodized) D (Dark Bronze Anodized)

PEMKO
ASSA ABLOY

Experience a safer
and more open world

SIM200A SERIES

For Sliding Doors up to 48" wide and 200 lbs.

Manufactured by P.C. Henderson

Side Wall Mount

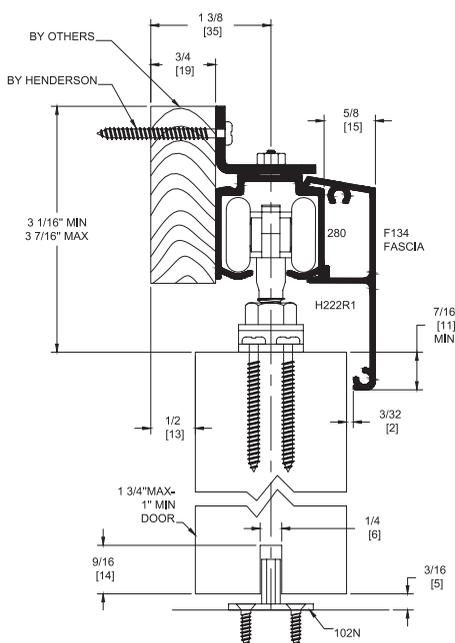

Overhead Mount

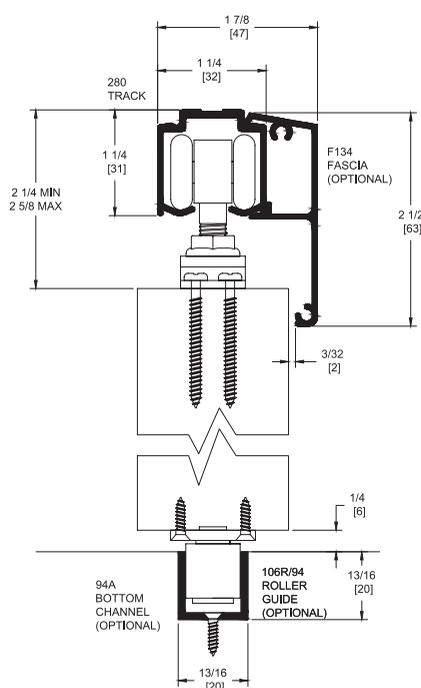

Simultaneous Action Unit (SIM) allows the simultaneous operation of two doors.

Configurations:

- Bi-parting

Installations:

- Overhead Mount
- Side Wall Mount

Features:

- Allows individual bi-part doors to act as a single operating unit. When one door is opened or closed, the second door operates simultaneously
- 200 lb. panel capacity
- Hanger body is made of nickel plated zinc alloy for durability and long life
- Steel ball bearing wheels coated in nylon for smooth operation
- Clear anodized aluminum track 280C
- 2 year warranty

SIM200A Kits Include:

- 1 ea **280C** Clear Anodized Aluminum Track
- 4 ea **H222R1** Hangers
- 4 ea **601H** Nylon In-Track Clip Stop
- 2 ea **102N** White Nylon Mortise Guide
- 1 ea **SIM100** Cable and Pulley Kit

Standard Kit Sizes

PART NUMBER	MATERIAL	TRACK LENGTH	DOOR WIDTH
SIM200A/6	Aluminum	72"	2 @ 18"
SIM200A/8	Aluminum	96"	2 @ 24"
SIM200A/12	Aluminum	2 @ 72"	2 @ 36"
SIM200A/16	Aluminum	2 @ 96"	2 @ 48"

Options:

Fascia

F134C clear anodized aluminum fascia
F134D dark bronze anodized fascia
280D dark bronze anodized

Side Wall Track Brackets

PC2815 available as 5 pack only,
PC2815 pack of 5 281 zinc plated side wall bracket.

NOTE: Need one at each end and no more than 2 feet in-between. Fasteners included.

End Plates
 Bottom Channel

K134EP (use with F134C only)
94A

Roller Guide

106R/94

Threshold

971A

Side Wall Mortise Guides

102WN (nylon) and **102WA** (steel)

Polypropylene Guide Rail

EPD3BL for use with 102N or 102WN

800-824-3018 | www.pemko.com

Check the web site for the up-to-date catalog

Copyright © 2015-2024, ASSA ABLOY Accessories and Door Controls Group, Inc., an ASSA ABLOY Group company. All rights reserved. Reproduction in whole or in part without the express written permission of ASSA ABLOY Accessories and Door Controls Group, Inc. is prohibited.

PEMKO
ASSA ABLOY

Experience a safer
 and more open world

LP200 SERIES

For Sliding Panels up to 200 lbs.

Manufactured by P.C. Henderson

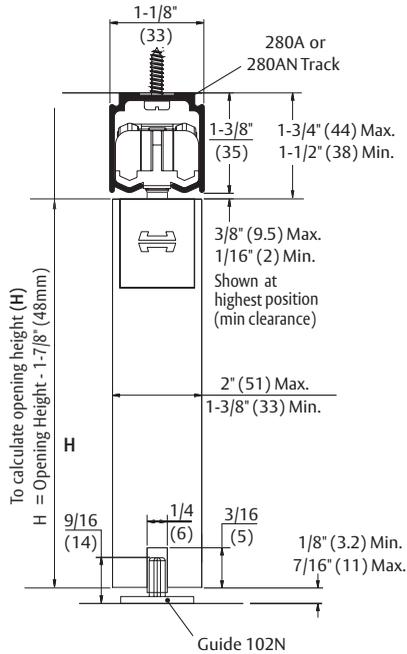

Low profile design for use where space is limited.

Configurations:

- Single
- Bi-parting

Installations:

- Overhead Mount
- Side Wall Mount

Features:

- Used to maximize door height
- Designed to give a modern clean finish with all parts concealed. Ideal for applications where minimal clearance between track and door is required
- Easy installation and adjustment
- 200 lb. panel capacity
- Needle bearing nylon wheels for smooth operation
- Clear anodized aluminum track 280C
- 2 year warranty
- Meets ADA push force requirements

LP200A Kits Include:

- 1 ea **280C** Clear Anodized Aluminum Track
- 1 ea **LH100** Hardware Kit

LH100 Hardware Kits Include:

- 2 ea Low Head Room Units
- 2 ea End Caps
- 2 ea In-Track Clip Stops
- 1 ea Screw Pack
- 2 ea Low Head Room Hangers
- 1 ea **102N** White Nylon Mortise Guide
- 1 ea Small Spanner and 4mm Allen Key

Standard Kit Sizes

PART NUMBER	MATERIAL	TRACK LENGTH	DOOR WIDTH
LP200A/6	Aluminum	72"	36"
LP200A/8	Aluminum	96"	48"
LP200A/10	Aluminum	120"	60"

Options:

Side Wall Track Bracket

PC2815 available as 5 pack only, **PC2815** pack of 5 281 zinc plated side wall bracket
NOTE: Need one at each end and no more than 2 feet in-between. Fasteners included.

Bottom Channel

94A

Roller Guide

106R/94

Threshold

971A

PEMKO
ASSA ABLOY

Experience a safer
and more open world

SIROCCO SERIES

For Sliding Panels up to 176 lbs.

Manufactured by P.C. Henderson

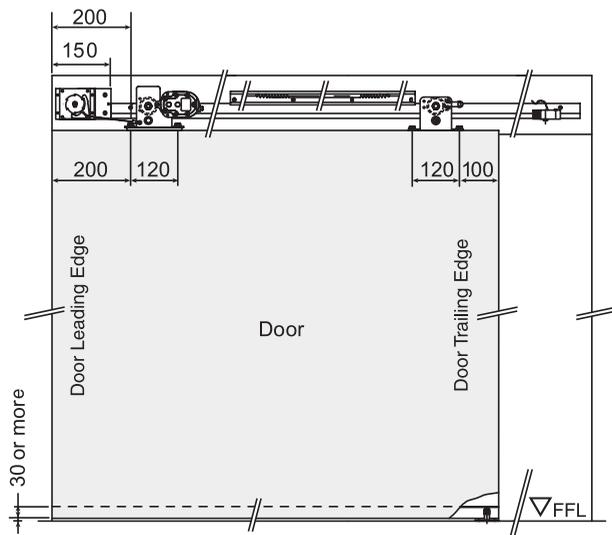

Right Hand SIRRH Shown Above and Below

The Sirocco system is a quiet, user friendly, self closing system which brings the door gently to a close.

The integrated hydraulic soft stop brings the door to a safe and cushioned close making it ideal for disabled access systems or public areas. The internal door brake can also be adjusted to allow the user to dictate the speed of opening preventing damage to the door and system.

Configurations:

- Single

Installations:

- Side Wall Mount

Features:

- Self closing system for a single door from 31½" to 47¼" wide and up to 176 lbs.
- Interior applications only
- Comes complete with a hydraulically controlled soft close feature
- Adjustable closing speed
- Door brake to reduce opening speed to prevent damage to the door and system
- Optional hold open unit giving adjustable time delay before self closing
- Operational between temperature ranges of 50 to 104 degrees Fahrenheit
- 2 year warranty
- Meets ADA push force requirements

Sirocco Series Kits Include:

- 1 ea Track 86.61" long
- 1 ea Leading hanger
- 1 ea Trailing hanger
- 1 ea Hydraulic Control Unit
- 1 ea Closing brake rack
- 1 ea Opening brake rack
- 1 ea Power spring mounting bracket
- 7 ea Height adjustment plates
- 1 ea Power spring unit
- 1 ea Guide roller
- 1 ea Opening door stop
- 1 ea Door stop roller
- 1 ea Closing door stop
- 2 ea Wooden door plate (and all required screws and bolts)

Standard Kits	
PART NUMBER	DESCRIPTION
SIRRH	Right Hand Opening Kit
SIRLH	Left Hand Opening Kit

H300S-OH SERIES

For Sliding Panels up to 300 lbs.
Manufactured by P.C. Henderson

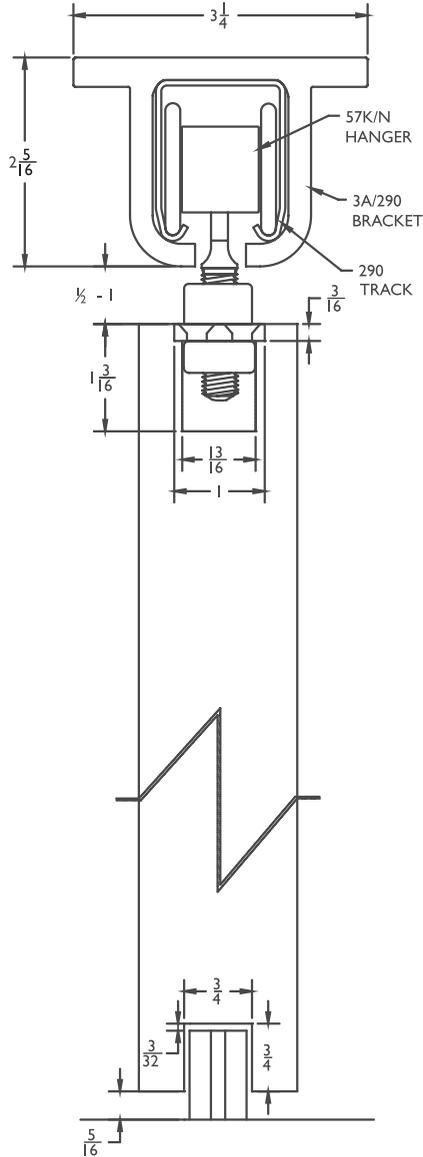

Configurations:

- Single
- Bi-parting

Installations:

- Overhead Mount

Features:

- Overhead mount system
- Nylon wheels for smooth operation
- 300 lb. panel capacity
- Galvanized steel track 290
- 2 year warranty

H300S-OH Kits Include:

- 1 ea **290** Galvanized Steel Track
- **3A/290** Aluminum Alloy Overhead Mount Track Brackets (One at each end and no more than 3 feet in between)
- 2 ea **1A/290/EC** Aluminum Alloy End Caps
- 2 ea **57K/N** White Nylon Body and Wheels, Zinc Coated Steel Pendant Bolt Hangers
- 2 ea **HH3/290** Galvanized Steel In-Track Stop
- 1 ea **89/2N** Gray Nylon Mortise Guide

Standard Kit Sizes

PART NUMBER	MATERIAL	TRACK LENGTH	DOOR WIDTH
H300S-OH/6	Steel	72"	36"
H300S-OH/8	Steel	96"	48"
H300S-OH/10	Steel	120"	60"
H300S-OH/12	Steel	144"	72"

Options:

- Bottom Channel **94A**
- Roller Guide **106R/94**
- Threshold **971A**
- Joining Bracket **3AX/290**
- Mortise Guides **102N**
- Stainless Steel Flush Bolt **FB150SS**
- Stainless Steel Flush Pull **503SF**



Experience a safer
and more open world

H300S-SW SERIES

For Sliding Panels up to 300 lbs.

Manufactured by P.C. Henderson

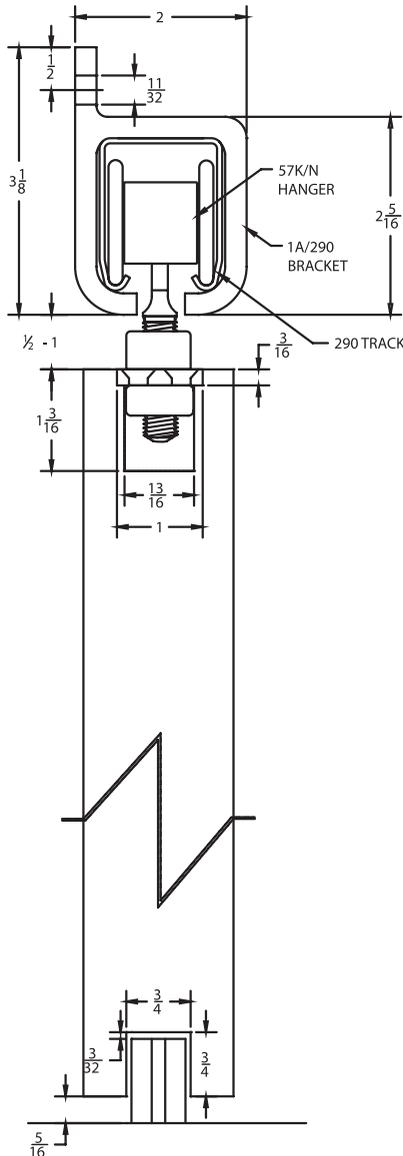

Configurations:

- Single
- Bi-parting

Installations:

- Side Wall Mount

Features:

- Side wall mount system
- Nylon wheels for smooth operation
- 300 lb. panel capacity
- Galvanized steel track 290
- 2 year warranty

H300S-SW Kits Include:

- 1 ea **290** Galvanized Steel Track
- **1A/290** Side Wall Mount Track Brackets (One at each end and no more than three feet in between)
- 2 ea **1A/290/EC** Aluminum Alloy End Caps
- 2 ea **57K/N** White Nylon Body and Wheels, Zinc Coated Steel Pendant Bolt Hangers
- 2 ea **HH3/290** Galvanized Steel In-Track Stops
- 1 ea **89/2N** Gray Nylon Mortise Guide

Standard Kit Sizes

PART NUMBER	MATERIAL	TRACK LENGTH	DOOR WIDTH
H300S-SW/6	Steel	72"	36"
H300S-SW/8	Steel	96"	48"
H300S-SW/10	Steel	120"	60"
H300S-SW/12	Steel	144"	72"

Options:

- Bottom Channel **94A**
- Roller Guide **106R/94**
- Mortise Guides **102N**
- Side Wall Mortise Guides **102WN** (nylon) and **102WA** (steel)
- Joining Bracket **1AX/290**
- Stainless Steel Flush Bolt **FB150SS**
- Stainless Steel Flush Pull **503SF**

H440A-OH SERIES

For Sliding Panels up to 440 lbs.
Manufactured by P.C. Henderson

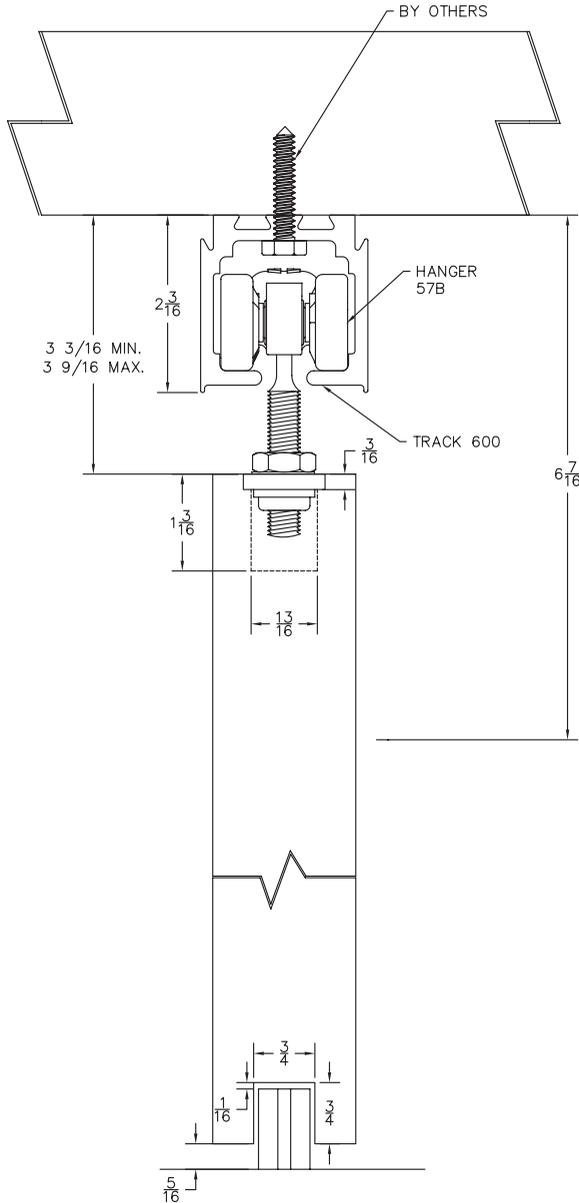

Configurations:

- Single
- Bi-parting

Installations:

- Overhead Mount

Features:

- Overhead mount system
- Nylon body and steel ball bearing nylon wheels for smooth operation
- 440 lb. panel capacity
- Mill finished aluminum track 600A
- 2 year warranty
- Meets ADA push force requirements

H440A-OH Kits Include:

- 1 ea **600A** Mill Finished Aluminum Track
- 2 ea **57B** Hangers: Gray Nylon Body, Zinc Coated Steel Pendant Bolt, Steel Ball Bearing Nylon Wheels
- 2 ea **601P** Nylon In-Track Clip Stop
- 1 ea **89/2N** Gray Nylon Mortise Guide

Standard Kit Sizes

PART NUMBER	MATERIAL	TRACK LENGTH	DOOR WIDTH
H440A-OH/6	Aluminum	72"	36"
H440A-OH/8	Aluminum	96"	48"
H440A-OH/10	Aluminum	120"	60"
H440A-OH/12	Aluminum	144"	72"
H440A-OH/16	Aluminum	192"	96"

Options:

- Bottom Channel **94A**
- Roller Guide **106R/94**
- Threshold **971A**
- Mortise Guides **102N**
- Stainless Steel Flush Bolt **FB150SS**
- Stainless Steel Flush Pull **503SF**

PEMKO
ASSA ABLOY

Experience a safer
and more open world

H440A-SW Series

For Sliding Panels up to 440 lbs.

Manufactured by P.C. Henderson

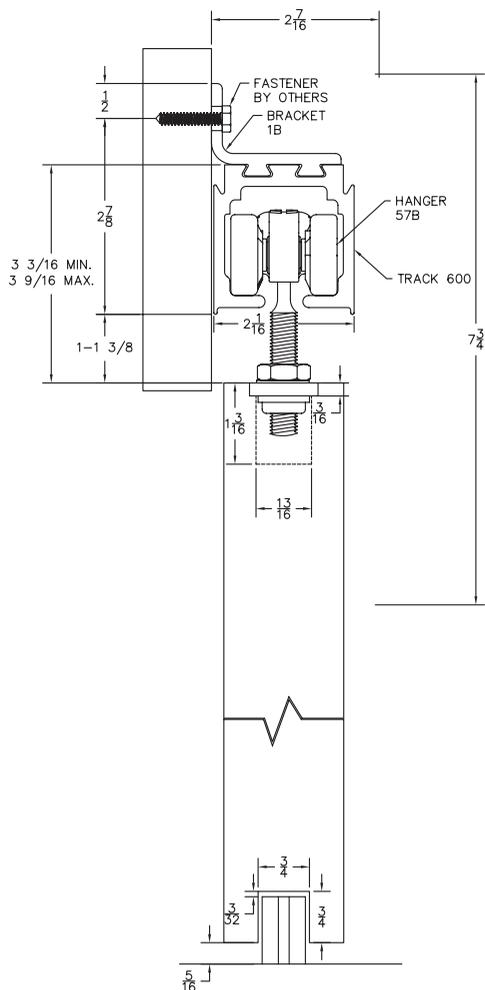

Configurations:

- Single
- Bi-parting

Installations:

- Side Wall Mount

Features:

- Side wall mount system
- Nylon body and steel ball bearing nylon wheels for smooth operation
- 440 lb. panel capacity
- Mill finished aluminum track 600A
- 2 year warranty
- Meets ADA push force requirements

H440A-SW Kits Include:

- 1 ea **600A** Mill Finished Aluminum Track
- **1B** Side Wall Mount Track Brackets (One at each end and no more than 3 feet in between)
- 2 ea **57B** Hangers: Gray Nylon Body, Zinc Coated Steel Pendant Bolt, Steel Ball Bearing Nylon Wheels
- 2 ea **601P** Nylon In-Track Clip Stop
- 1 ea **89/2N** Gray Nylon Mortise Guide

Standard Kit Sizes

PART NUMBER	MATERIAL	TRACK LENGTH	DOOR WIDTH
H440A-SW/6	Aluminum	72"	36"
H440A-SW/8	Aluminum	96"	48"
H440A-SW/10	Aluminum	120"	60"
H440A-SW/12	Aluminum	144"	72"
H440A-SW/16	Aluminum	192"	96"

Options:

- Bottom Channel **94A**
- Roller Guide **106R/94**
- Mortise Guides **102N**
- Side Wall Mortise Guides **102WN** (nylon) and **102WA** (steel)
- Joining Bracket **1BX**
- Stainless Steel Flush Bolt **FB150SS**
- Stainless Steel Flush Pull **503SF**

800-824-3018 | www.pemko.com

Check the web site for the up-to-date catalog

Copyright © 2015-2024, ASSA ABLOY Accessories and Door Controls Group, Inc., an ASSA ABLOY Group company. All rights reserved.
Reproduction in whole or in part without the express written permission of ASSA ABLOY Accessories and Door Controls Group, Inc. is prohibited.

PEMCO
ASSA ABLOY

Experience a safer
and more open world

TBS250A-OH Series

For Sliding Panels up to 250 lbs.

Manufactured by Pemko Manufacturing

Configurations:

- Single
- Bi-parting

Installations:

- Overhead Mount

Features:

- Overhead mount system
- Nylon body and steel ball bearing nylon wheels for smooth operation
- 250 lb. panel capacity
- Mill finished aluminum track 600A
- 2 year warranty
- Meets ADA push force requirements

TBS250A-OH Kits Include:

- 1 ea **600A** Mill Finished Aluminum Track
- 2 ea **56B** Hangers: Gray Nylon Body, Zinc Coated Steel Pendant Bolt, Steel Ball Bearing Nylon Wheels
- 2 ea **53B/APRON** Mounting Brackets Thru-bolted
- 1 ea **ADJ-BG** Surface Type Guide
- 2 ea **601P** Nylon In-Track Clip Stop

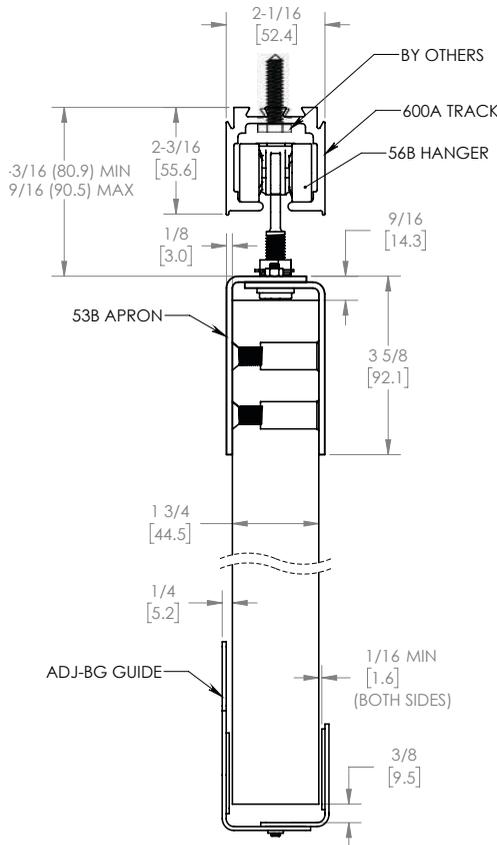

Standard Kit Sizes

PART NUMBER	MATERIAL	TRACK LENGTH	DOOR WIDTH
TBS250A-OH/6	Aluminum	72"	36"
TBS250A-OH/8	Aluminum	96"	48"
TBS250A-OH/10	Aluminum	120"	60"
TBS250A-OH/12	Aluminum	144"	72"
TBS250A-OH/16	Aluminum	192"	96"

PEMKO
ASSA ABLOY

Experience a safer
and more open world

TBS250A-SW Series

For Sliding Panels up to 250 lbs.

Manufactured by Pemko Manufacturing

Configurations:

- Single
- Bi-parting

Installations:

- Side Wall Mount

Features:

- Side wall mount system
- Nylon body and steel ball bearing nylon wheels for smooth operation
- 250 lb. panel capacity
- Mill finished aluminum track 600A
- 2 year warranty
- Meets ADA push force requirements

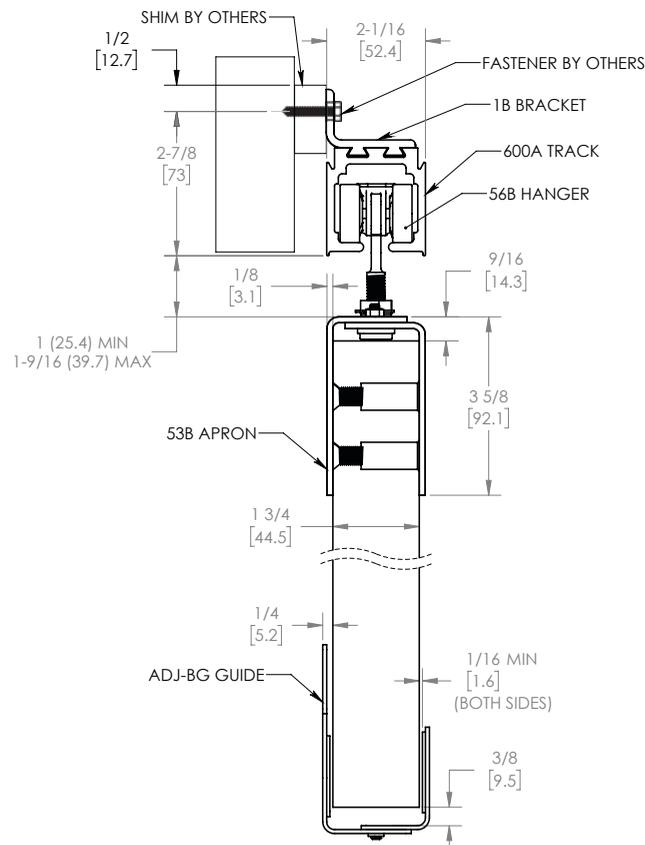

TBS250A-SW Kits Include:

- 1 ea **600A** Mill Finished Aluminum Track
- **1B** Side Wall Mount Track Brackets (One at each end and no more than 3 feet in between)
- 2 ea **56B** Hangers: Gray Nylon Body, Zinc Coated Steel Pendant Bolt, Steel Ball Bearing Nylon Wheels
- 2 ea **53B/APRON** Mounting Brackets Thru-bolted
- 1 ea **ADJ-BG** Surface Type Guide
- 2 ea **601P** Nylon In-Track Clip Stop

Standard Kit Sizes			
PART NUMBER	MATERIAL	TRACK LENGTH	DOOR WIDTH
TBS250A-SW/6	Aluminum	72"	36"
TBS250A-SW/8	Aluminum	96"	48"
TBS250A-SW/10	Aluminum	120"	60"
TBS250A-SW/12	Aluminum	144"	72"
TBS250A-SW/16	Aluminum	192"	96"

H600S-OH Series

For Sliding Panels up to 600 lbs.
Manufactured by P.C. Henderson

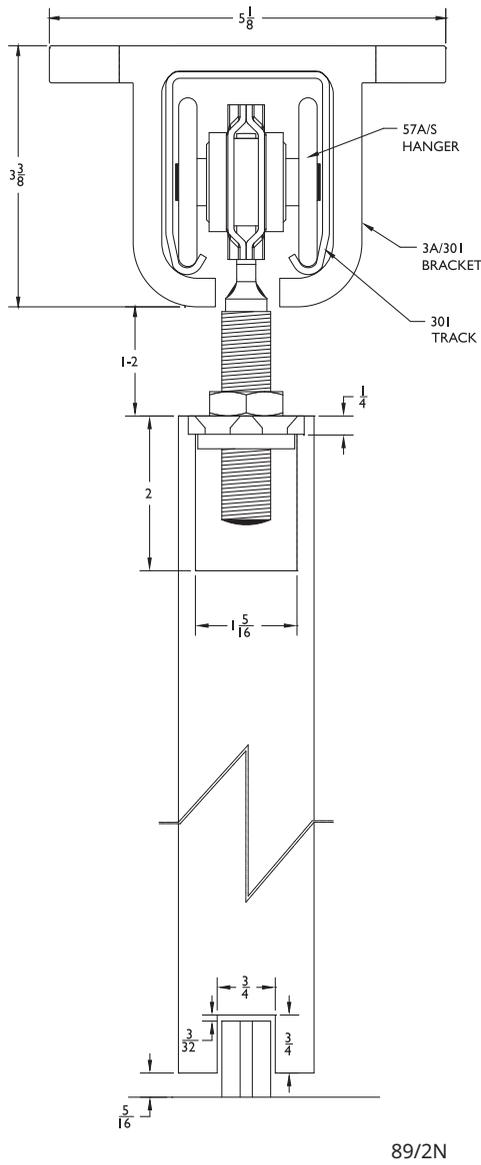

89/2N

Configurations:

- Single
- Bi-parting

Installations:

- Overhead Mount

Features:

- Overhead mount system
- Heavy duty zinc coated steel
- Ball bearing wheels
- 600 lb. panel capacity
- Galvanized steel track 301
- 2 year warranty

H600S-OH Kits Include:

- 1 ea **301** Galvanized Steel Track
- **3A/301** Aluminum Alloy Overhead Mount Track Brackets
(One at each end and no more than three feet in between)
- 2 ea **1A/301/EC** Aluminum Alloy End Caps
- 2 ea **57A/S** Zinc Coated Steel Body, Wheels, and Pendant Bolt Hangers
- 2 ea **HH3/301** Galvanized Steel In-Track Stops
- 1 ea **89/2N** Gray Nylon Mortise Guide

Standard Kit Sizes

PART NUMBER	MATERIAL	TRACK LENGTH	DOOR WIDTH
H600S-OH/8	Steel	96"	48"
H600S-OH/10	Steel	120"	60"
H600S-OH/12	Steel	144"	72"

Options:

Bottom Channel	94A
Roller Guide	106R/94
Mortise Guides	102N
Threshold	971A
Joining Bracket	3AX/301
Stainless Steel Flush Bolt	FB150SS
Stainless Steel Flush Pull	503SF

PEMKO
ASSA ABLOY

Experience a safer
and more open world

H600S-SW SERIES

For Sliding Panels up to 600 lbs.

Manufactured by P.C. Henderson

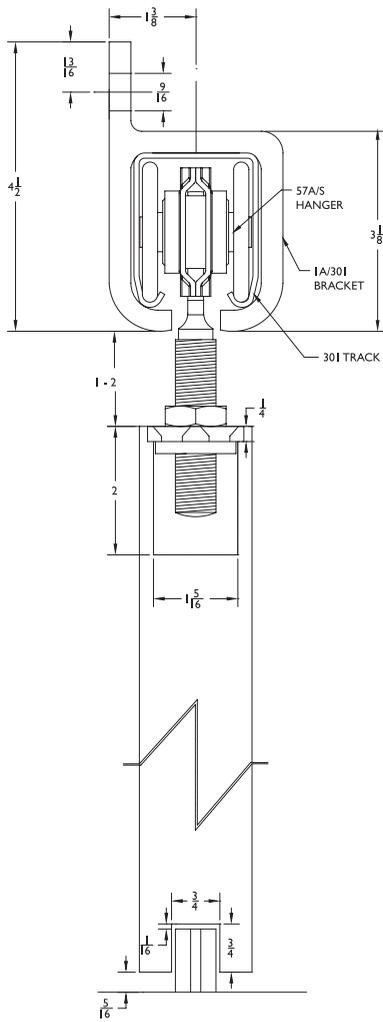

89/2N

Configurations:

- Single
- Bi-parting

Installations:

- Side Wall Mount

Features:

- Side wall mount system
- Heavy duty zinc coated steel
- Ball bearing wheels
- 600 lb. panel capacity
- Galvanized steel track 301
- 2 year warranty

H600S-SW Kits Include:

- 1 ea **301** Galvanized Steel Track
- **1A/301** Side Wall Mount Track Brackets
(One at each end and no more than three feet in between)
- 2 ea **1A/301/EC** Aluminum Alloy End Caps
- 2 ea **57A/S** Zinc Coated Steel Body, Wheels, and Pendant Bolt Hangers
- 2 ea **HH3/301** Galvanized Steel In-Track Stops
- 1 ea **89/2N** Gray Nylon Mortise Guide

Standard Kit Sizes

PART NUMBER	MATERIAL	TRACK LENGTH	DOOR WIDTH
H600S-SW/8	Steel	96"	48"
H600S-SW/12	Steel	144"	72"

Options:

- Bottom Channel **94A**
- Roller Guide **106R/94**
- Mortise Guides **102N**
- Side Wall Mortise Guides **102WN**
- Joining Bracket **1AX/301**
- Stainless Steel Flush Bolt **FB150SS**
- Stainless Steel Flush Pull **503SF**

H800S-OH SERIES

For Sliding Panels up to 800 lbs.

Manufactured by P.C. Henderson

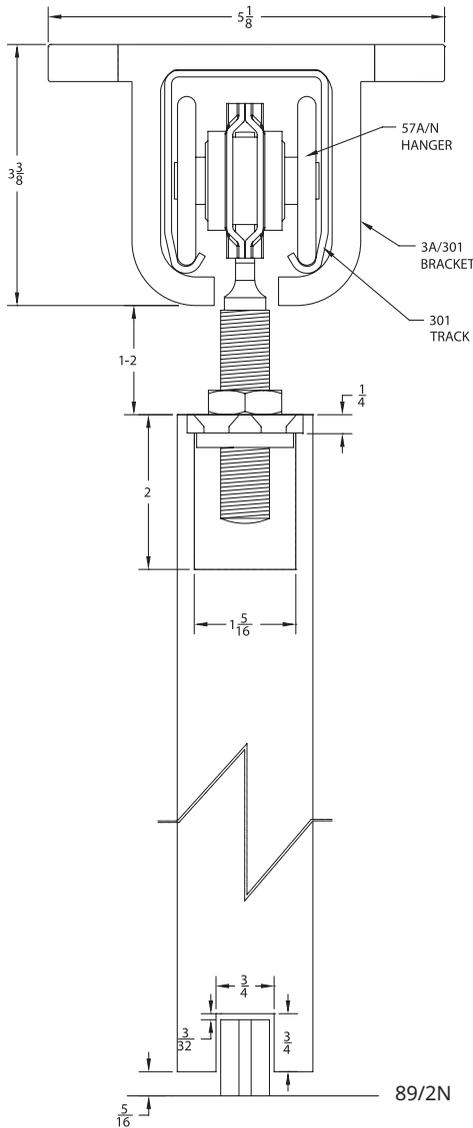

Configurations:

- Single
- Bi-parting

Installations:

- Overhead Mount

Features:

- Overhead mount system
- Heavy duty zinc coated steel body
- Ball bearing nylon wheels for smooth operation
- 800 lb. panel capacity
- Galvanized steel track 301
- 2 year warranty

H800S-OH Kits Include:

- 1 ea **301** Galvanized Steel Track
- **3A/301** Overhead Mount Track Brackets (One at each end and no more than three feet in between)
- 2 ea **1A/301/EC** Aluminum Alloy End Caps
- 2 ea **57A/N** Zinc Coated Steel Body, Nylon Wheels, and Pendant Bolt Hangers
- 2 ea **HH3/301** Galvanized Steel In-Track Stop
- 1 ea **89/2N** Gray Nylon Mortise Guide

Standard Kit Sizes

PART NUMBER	MATERIAL	TRACK LENGTH	DOOR WIDTH
H800S-OH/8	Steel	96"	48"
H800S-OH/10	Steel	120"	60"

Options:

- Bottom Channel **94A**
- Roller Guide **106R/94**
- Mortise Guides **102N**
- Threshold **971A**
- Joining Bracket **3AX/301**
- Stainless Steel Flush Bolt **FB150SS**
- Stainless Steel Flush Pull **503SF**

PEMKO
ASSA ABLOY

Experience a safer
and more open world

H800S-SW SERIES

For Sliding Panels up to 800 lbs.
Manufactured by P.C. Henderson

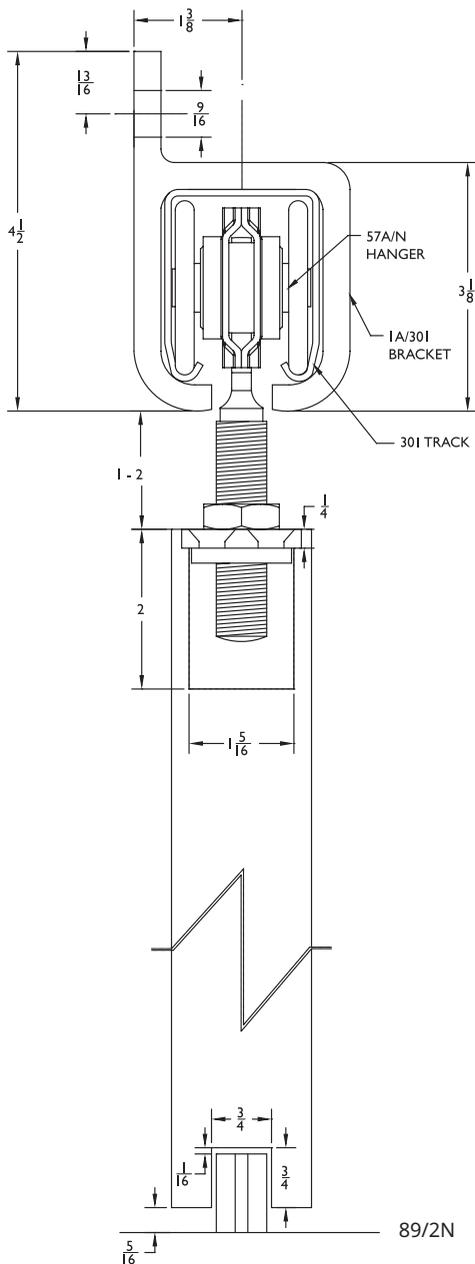

Configurations:

- Single
- Bi-parting

Installations:

- Side Wall Mount

Features:

- Side wall mount system
- Heavy duty zinc coated steel body
- Heavy ball bearing nylon wheels for smooth operation
- 800 lb. panel capacity
- Galvanized steel track 301
- 2 year warranty

H800S-SW Kits Include:

- 1 ea **301** Galvanized Steel Track
- **1A/301** Aluminum Alloy Side Wall Mount Track Brackets (One at each end and no more than three feet in between)
- 2 ea **1A/301/EC** Aluminum Alloy End Caps
- 2 ea **57A/N** Zinc Coated Steel Body, Nylon Wheels, and Pendant Bolt Hangers
- 2 ea **HH3/301** Galvanized Steel In-Track Stops
- 1 ea **89/2N** Gray Nylon Mortise Guide

Standard Kit Sizes			
PART NUMBER	MATERIAL	TRACK LENGTH	DOOR WIDTH
H800S-SW/6	Steel	72"	36"
H800S-SW/10	Steel	120"	60"
H800S-SW/12	Steel	144"	72"

Options:

- Bottom Channel **94A**
- Roller Guide **106R/94**
- Mortise Guides **102N**
- Side Wall Mortise Guides **102WN** (nylon) and **102WA** (steel)
- Joining Bracket **1AX/301**
- Stainless Steel Flush Bolt **FB150SS**
- Stainless Steel Flush Pull **503SF**

H1100A-OH SERIES

For Sliding Panels up to 1100 lbs.
 Manufactured by P.C. Henderson

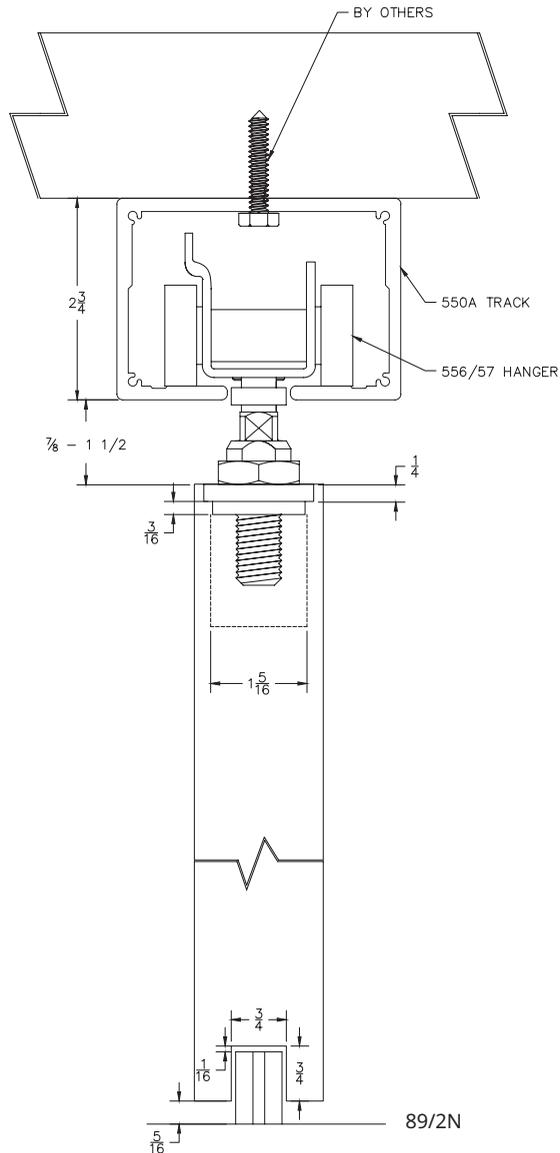

Ideally suited for large doors that require high performance and an attractive finish.

Typical applications are hotels, conference centers, shop-fronts and showrooms.

Configurations:

- Single
- Bi-parting

Installations:

- Overhead Mount

Features:

- For top hung wood and metal doors
- Heavy duty black painted steel body
- Ball bearing steel wheels
- 1100 lb. panel capacity
- Mill finished aluminum track 550A
- 2 year warranty

H1100A-OH Kits Include:

- 1 ea **550A** Mill Finished Aluminum Track
- 2 ea **556/57** Painted Black Steel Body - Zinc Coated Steel Wheels and Pendant Bolt Hangers
- 2 ea **HH3/301** Galvanized Steel In-Track Stops
- 1 ea **89/2N** Gray Nylon Mortise Guide

Standard Kit Sizes

PART NUMBER	MATERIAL	TRACK LENGTH	DOOR WIDTH
H1100A-OH/6	Aluminum	72"	36"
H1100A-OH/8	Aluminum	96"	48"
H1100A-OH/10	Aluminum	120"	60"
H1100A-OH/12	Aluminum	144"	72"
H1100A-OH/16	Aluminum	197"	98"

Options:

- Bottom Channel **94A**
- Roller Guide **106R/94**
- Threshold **971A**
- Stainless Steel Flush Bolt **FB150SS**
- Stainless Steel Flush Pull **503SF**



Experience a safer and more open world

HUSKY SLIDING GLASS SERIES

For Sliding Panels up to 165 lbs.
 Manufactured by P.C. Henderson

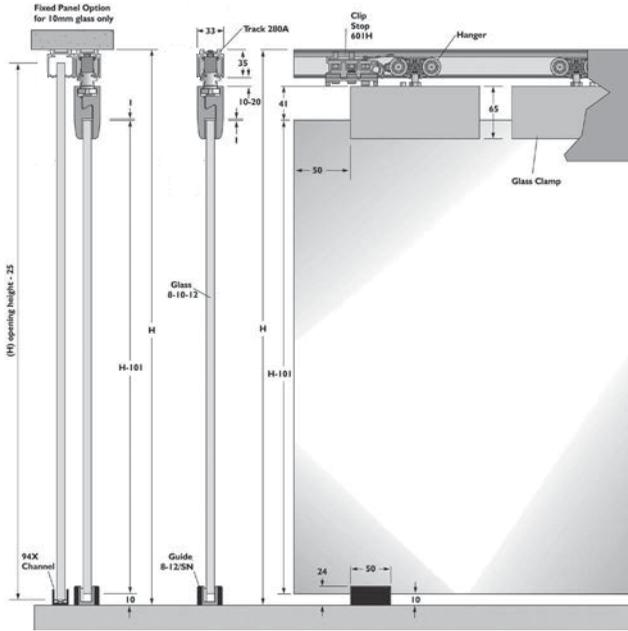

For lightweight glass applications such as office doors and small glass partitions.
 • 2 year warranty

Capacity:

- Max. door weight 165 lbs. (75kg)
- Max. door height 7' 10" (2400mm)
- Max. door width 4' 1" (1250mm)
- Glass thickness 5/16" (8mm) & 3/8" (10mm)

Door Types:

Glass panels of 5/16" (8mm) or 3/8" (10mm) thickness in tempered or laminated glass.
 Meets ADA push force requirements

8/HY/75 and 10/HY/75 HUSKY Glass Clamp Kit:

- 8/HY/75 is for 8mm or 5/16" thick glass
- 10/HY/75 kit is for 10mm or 3/8" thick glass
- 2 ea **284D** Hangers
- 2 ea GLASS Clamps
- 2 ea **601H** End stops
- 1 ea **8-12/SN** adjustable guide for 5/16" or 3/8" glass guide

Standard Track Sizes		
PART NUMBER	MATERIAL	STANDARD TRACK SIZES (Track Ordered Separately)
280C72	Aluminum	72"
280C96	Aluminum	96"

Options:

- Face mount bracket: **PC2815** available as 5 pack only, **PC2815** pack of 5 281 zinc plated side wall bracket. NOTE: Need one at each end and no more than 2 feet in-between. Fasteners included.
- Guides: **8-12/SN** adjustable guide for 5/16" or 3/8" glass guide
- Accessories: **601H** retaining stop mounted within the track



Experience a safer and more open world

POCKET FRAME KIT

For Sliding Panels up to 200 lbs.

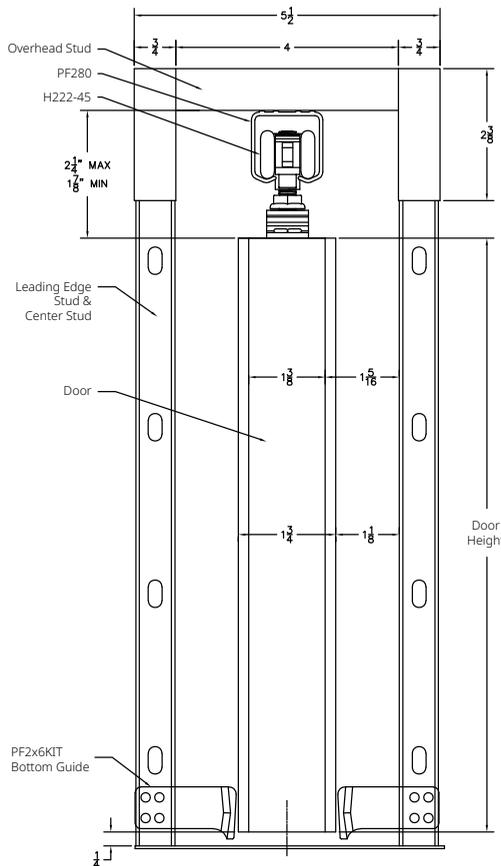

NOTE: 3/4" plywood can be installed to the studs in the pocket to add strength and rigidity to pocket door walls.

Rough Frame Opening Dimensions:
2 x Door Width + 1" and Door Height + 5"

Features:

- Heavy duty hardware supports doors up to 200 lbs. each
- Standard kit is for 1 3/8" door. For 1 3/4" door, MUST use PF134KIT (see Options below)
- For standard 3 1/2" studs only. Not for use with 2x6 or SP6 kits
- Chrome plated steel hangers are corrosion resistant and no maintenance is required
- 5 year warranty
- Meets ADA push force requirements

Pocket Frame Kit Includes:

- 1 ea Header Track Assembly
- 4 ea **PFAS**_ Aluminum Cased Wood Studs
- 2 ea **PFHB-1** and **PFHB-2** Pre-Mounted Header Brackets
- 2 ea **H222R1** Hangers
- 2 ea **PFFC-8** Floor Cleats
- 1 ea **PFBS** Pocket Frame Bumper Stop
- 1 ea **Bottom Guide**
- PFBG-8** Pocket Frame Bottom Guide for 1 3/8" thick doors mounting hardware
- PF2x6KIT** Pocket Frame Bottom Guide for 2x6 and SP6 kit

Standard Kit Sizes			
2x4 Wood or Metal Stud Constructed Walls	2x6 Wood Stud Constructed Walls	2x6 Metal Stud Constructed Walls	Net Door Size (The Kits can be trimmed in field)
PF28200A6080	PF28200A6080-2x6	PF28200A6080-SP6	2'6" x 6'8"
PF28200A7280	PF28200A7280-2x6	PF28200A7280-SP6	3'0" x 6'8"
PF28200A9680	PF28200A9680-2x6	PF28200A9680-SP6	4'0" x 6'8"
PF28200A6084	PF28200A6084-2x6	PF28200A6084-SP6	2'6" x 7'0"
PF28200A7284	PF28200A7284-2x6	PF28200A7284-SP6	3'0" x 7'0"
PF28200A9684	PF28200A9684-2x6	PF28200A9684-SP6	4'0" x 7'0"
PF28200A6096	PF28200A6096-2x6	PF28200A6096-SP6	2'6" x 8'0"
PF28200A7296	PF28200A7296-2x6	PF28200A7296-SP6	3'0" x 8'0"
PF28200A9696	PF28200A9696-2x6	PF28200A9696-SP6	4'0" x 8'0"

Options:

- PF134 KIT** - Recommended for use with 1 3/4" thick doors in 2x4 constructed wall kits (3 1/2" stud). Not for use with 2x6 or SP6 stud kits.
 - PFAS84** - For doors over 3' wide an extra pair of 84" center studs with floor cleat for 80" tall doors recommended
 - PFAS88** - For doors over 3' wide an extra pair of 88" center studs with floor cleat for 84" tall doors recommended
 - PFAS100** - For doors over 3' wide an extra pair of 100" center studs with floor cleat for 96" tall doors recommended
 - PFCDKIT** - Conversion Kit to achieve a bipart double door frame
 - PFKIT-4** - Replacement Hardware Kit for Pemko Pocket Frame Kit for 1 3/4" thick doors (Each contains 2-H222-45 Hangers, 1-PFBS Bumper Stop, 1- PFBG-4 Guide, 2 PFHS Header Shims, 2-PFFC-4 Floor Cleats)
 - PFKIT-8** - Replacement Hardware Kit for Pemko Pocket Frame Kit for 1 3/8" thick doors (Each contains 2-H222-45 Hangers, 1-PFBS Bumper Stop, 1- PFBG-8 Guide, 2-PFFC-8 Floor Cleats)
- Soft Close available. See pages 275-277 for more information.



Experience a safer and more open world

FOLDING 100 SERIES

**For Folding Doors up to 100 lbs.
For Doors up to 24" Wide x 96" Tall**
Manufactured by P.C. Henderson

280C Overhead Mounted

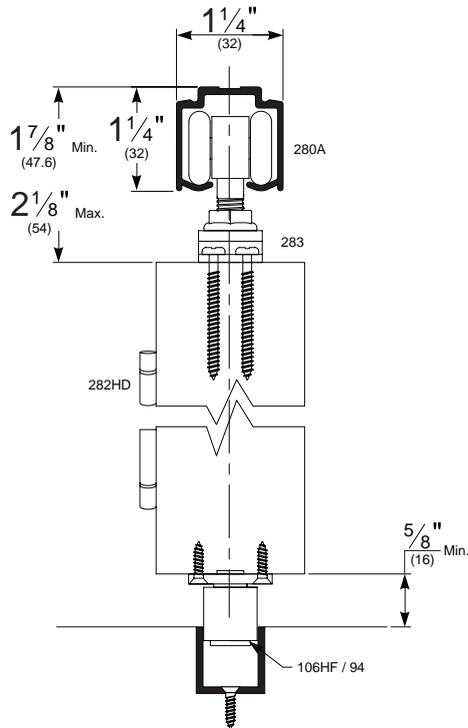

Features:

- For medium weight folding doors
- Two and four leaf kits are available
- 2 year warranty

Two Panel:

HF2/100A Kits Include:

- 1 ea **280C** Clear Anodized Track
- 1 ea **283** Hanger
- 1 ea **289T** Top Pivot
- 1 ea **289B** Bottom Pivot
- 3 ea **282HD26** Hinges
- 1 ea **106HF/94** Roller Guide
- 1 ea **94A** Aluminum Guide Channel
- 1 ea Adjusting Wrench and Mounting Hardware

Four Panel:

HF4/100A Kits Include:

- 1 ea **280C** Clear Anodized Track
- 2 ea **283** Hangers
- 2 ea **289T** Top Pivots
- 2 ea **289B** Bottom Pivots
- 6 ea **282HD26** Hinges
- 2 ea **106HF/94** Roller Guide
- 1 ea **94A** Aluminum Guide Channel
- 1 ea Adjusting Wrench and Mounting Hardware

Standard Kit Sizes			
PART NUMBER	MATERIAL	# OF PANELS	TRACK LENGTH
HF2/100A/2	Aluminum	2	24"
HF2/100A/2'6	Aluminum	2	30"
HF2/100A/3	Aluminum	2	36"
HF2/100A/4	Aluminum	2	48"
HF4/100A/4	Aluminum	4	48"
HF4/100A/5	Aluminum	4	60"
HF4/100A/6	Aluminum	4	72"
HF4/100A/8	Aluminum	4	96"

Options:

- Mounting Bracket **PC2815** available as 5 pack only, **PC2815** pack of 5 281 zinc plated side wall bracket.
NOTE: Need one at each end and no more than 2 feet in-between. Fasteners included.
- Threshold **971A**
- Track **280D** dark bronze anodized aluminum

Note: Allow 1/4" clearance at pivot jambs and 1/8" in between hinged doors if hinges are mortised. Allow 3/16" between hinged doors if hinges are surface mounted. Allow 1/8" between doors meeting in the center of the opening on HF4 kits and allow 1/8" between wall and end panel on HF2 kits.



Experience a safer
and more open world

PACER INTERIOR END FOLD SERIES

**For Folding Doors and Room Dividers up to 165 lbs.
For Doors up to 36" Wide x 106" Tall**

Manufactured by P.C. Henderson



Features:

- For top-hung, medium weight, interior, partition doors
- Ideal in both residential and commercial applications requiring end folding doors
- 2 year warranty

Two Panel: plan 1

PIF2/165A Kits Include:

- 1 ea **600A** Mill Finished Aluminum Track
- 1 ea **21B/P** Top and Bottom Pivot Assembly
- 1 ea **21B/4** Nylon Body and Wheels, Zinc Coated Steel Pendant Bolt and Door Bracket Hanger
- 1 ea **21N/94** Nylon Roller Guide on Zinc Coated Steel Door Bracket Bottom Guide
- 4 ea **403/2** Aluminum Alloy Butt Hinges
- 1 ea **94A** Aluminum Guide Channel

Four Panel: plan 2

PIF4/165A Kits Include:

- 1 ea **600A** Mill Finished Aluminum Track
- 2 ea **21B/P** Top and Bottom Pivot Assembly
- 2 ea **21B/4** Nylon Body and Wheels, Zinc coated steel Pendant Bolt and Door Bracket Hanger
- 2 ea **21N/94** Nylon Roller Guide on Zinc Coated Steel Door Bracket Bottom Guide
- 8 ea **403/2** Aluminum Alloy Butt Hinges
- 1 ea **94A** Aluminum Guide Channel

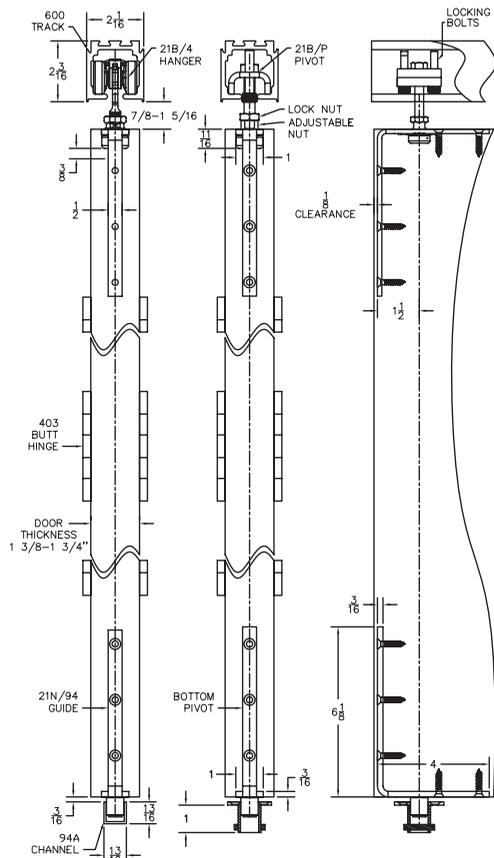

Standard Kit Sizes

PART NUMBER	MATERIAL	# OF PANELS	TRACK LENGTH
PIF2/165A/6	Aluminum	2	72"
PIF4/165A/6	Aluminum	4	72"
PIF4/165A/8	Aluminum	4	96"
PIF4/165A/12	Aluminum	4	2 @ 72"

Options:

- Threshold **971A**
- Stainless Steel Flush Bolt **FB150SS**
- Stainless Steel Flush Pull **503SF**

NOTE: Allow 3/8" clearance at pivot jambs and 1/8" in between hinged doors if hinges are mortised. Allow 7/16" between hinged doors if hinges are surface mounted. Allow 1/8" between doors meeting in the center of the opening on PIF4 kits and allow 1/8" between wall and end panel on PIF2 kits.

800-824-3018 | www.pemko.com

Check the web site for the up-to-date catalog

Copyright © 2015-2024, ASSA ABLOY Accessories and Door Controls Group, Inc., an ASSA ABLOY Group company. All rights reserved. Reproduction in whole or in part without the express written permission of ASSA ABLOY Accessories and Door Controls Group, Inc. is prohibited.

PEMCO
ASSA ABLOY

Experience a safer
and more open world

STAINLESS STEEL SLIDING TRACK HARDWARE SYSTEM

W60 SERIES FOR WOOD DOORS

For Sliding Panels up to 176 lbs.

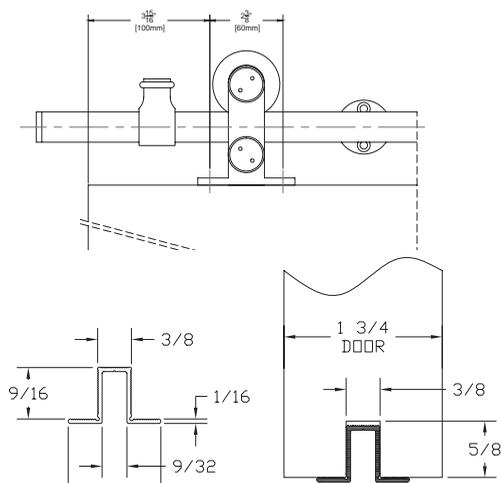
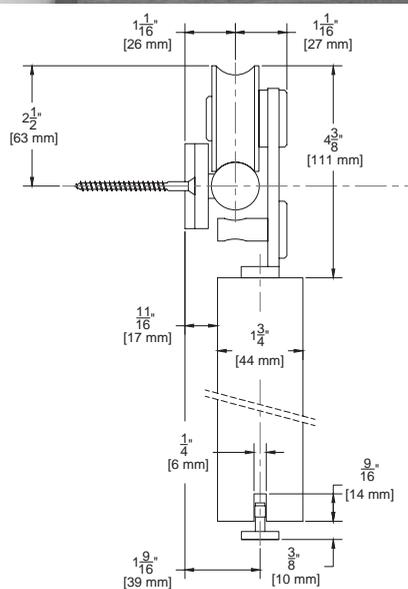
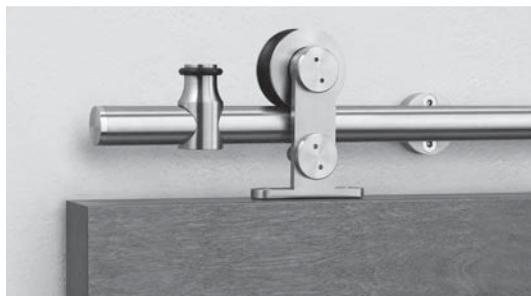

NOTE: Alternate route dimension when using optional EPD3BL

Configurations:

- Single
- Bi-parting

Installations:

- Side Wall Mount (only)

Features:

- Made of 304 stainless steel
- Nylon coated stainless steel wheel for smooth operation
- 176 lb. panel capacity
- 5 year warranty
- Meets ADA push force requirements

Finishes:

- Brushed Stainless Steel (W60)
- Black Powder Coated Stainless Steel (W60D)
- Polished Stainless Steel (W60P)

W60 Kits Include:

- 1 ea **BAR/** Stainless Steel Track
- **BRACKET2** Stainless Steel Wall Brackets
- 2 ea **62** Stainless Steel Hangers
- 1 ea **102SS-KIT** Stainless Steel Guide
- 2 ea **STOP2** Stainless Steel Stops Mounting Hardware

NOTE: If ordering individual parts in the optional Black Powder Coat, Polished finishes be sure to include a prefix "D" for Black Powder Coat, "P" for Polished Stainless

Standard Kit Sizes			
PART NUMBER	MATERIAL	TRACK LENGTH	DOOR WIDTH
W60/6	304 Stainless Steel	78 ³ / ₄ "	36"
W60/8	304 Stainless Steel	98 ⁷ / ₁₆ "	48"
W60D/6	Black Powder Coated Stainless Steel	78 ³ / ₄ "	36"
W60D/8	Black Powder Coated Stainless Steel	98 ⁷ / ₁₆ "	48"
W60P/6	304 Polished Stainless Steel	78 ³ / ₄ "	36"
W60P/8	304 Polished Stainless Steel	98 ⁷ / ₁₆ "	48"

Custom lengths are available. Please contact the factory to order.

Options:

- Hardware Pack (One Door)
- Mortise Guides
- Polypropylene Guide Rail
- 5/8" Spacer

W60_H/PACK

102N

EPD3BL For Use With 102N

BLD-SPACER-58 Pack of 5 5/8" Spacer Recommended for use with 5/8" Gypsum Board When Mounting Track Directly to Gypsum Board

800-824-3018 | www.pemko.com

Check the web site for the up-to-date catalog

Copyright © 2015-2024, ASSA ABLOY Accessories and Door Controls Group, Inc., an ASSA ABLOY Group company. All rights reserved. Reproduction in whole or in part without the express written permission of ASSA ABLOY Accessories and Door Controls Group, Inc. is prohibited.



Experience a safer and more open world

STAINLESS STEEL SLIDING TRACK HARDWARE SYSTEM WITH CUSHION STOP

CS-W60 SERIES FOR WOOD DOORS

For Sliding Panels up to 176 lbs.

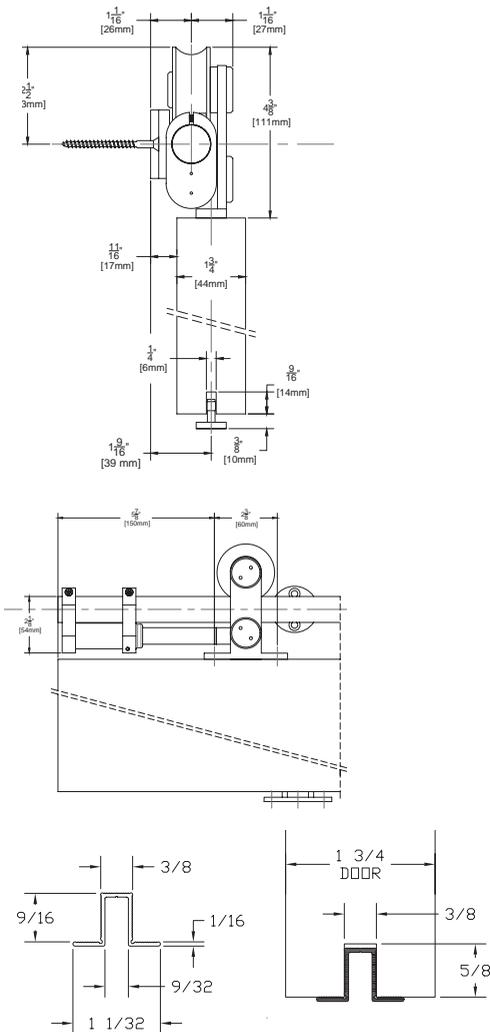
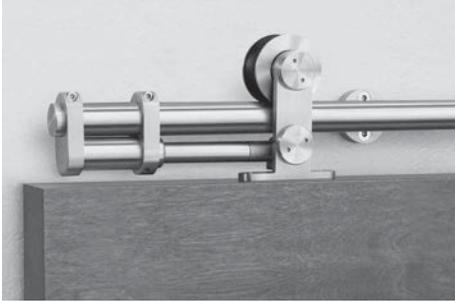

NOTE: Alternate route dimension when using optional EPD3BL



Experience a safer and more open world

Configurations:

- Single

Installations:

- Side Wall Mount (only)

Features:

- Made of 304 stainless steel
- Prevents door racking and bounce back
- Extends life of upper hardware
- Nylon coated stainless steel wheel for smooth operation
- 176 lb. panel capacity
- 5 year warranty
- Meets ADA push force requirements

Finishes:

- Brushed Stainless Steel
- Black Powder Coated Stainless Steel

CS-W60 Kits Include:

- 1 ea **BAR/_** Stainless Steel Track
- **BRACKET2** Stainless Steel Wall Brackets
- 2 ea **62** Stainless Steel Hangers
- 1 ea **102SS-KIT** Stainless Steel Guide
- 1 pr **CS-001SS** Stainless Steel Cushion Stops

NOTE: If ordering individual parts in the optional Black Powder Coated Stainless Steel or Polished finishes, be sure to include a suffix "D" for Black Powder Coated Stainless Steel or "P" for Polished Stainless

Standard Kit Sizes			
PART NUMBER	MATERIAL	TRACK LENGTH	DOOR WIDTH
CS-W60/6	304 Stainless Steel	78 ³ / ₄ "	36"
CS-W60/8	304 Stainless Steel	98 ⁷ / ₁₆ "	48"
CS-W60D/6	304 Black Powder Coated Stainless Steel	78 ³ / ₄ "	36"
CS-W60D/8	304 Black Powder Coated Stainless Steel	98 ⁷ / ₁₆ "	48"

Custom lengths are available. Please contact the factory to order.

Options: See page 278

- Mortise Guides
- Polypropylene Guide Rail
- Cushion Stops

5/8" Spacer

102N

EPD3BL For Use With 102SS-KIT

CS-001SS (sold as pair) For use with existing openings that have W60 hardware installed

BLD-SPACER-58 Pack of 5 5/8" Spacer

Recommended for use with 5/8" Gypsum Board When Mounting Track Directly to Gypsum Board

SOFT CLOSE STAINLESS STEEL SLIDING TRACK HARDWARE SYSTEM

SFT-W60 SERIES FOR WOOD DOORS

For Sliding Panels up to 176 lbs.

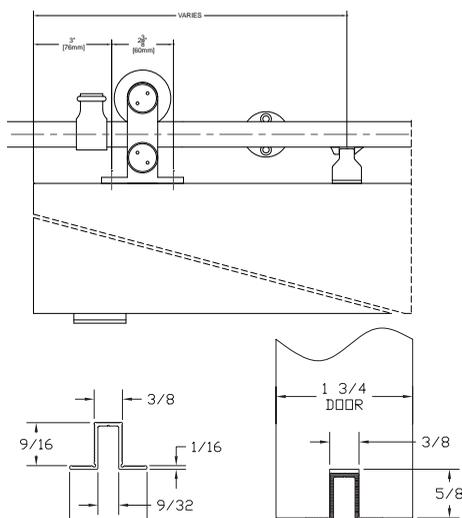
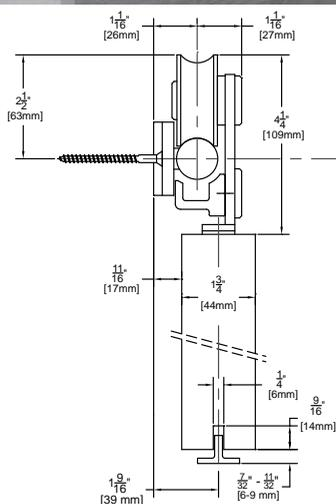

NOTE: Alternate route dimension when using optional EPD3BL

Configurations:

- Single

Installations:

- Side Wall Mount (only)

Features:

- Made of 304 stainless steel
- Soft Close
- Nylon coated stainless steel wheel for smooth operation
- 176 lb. panel capacity
- 5 year warranty
- Meets ADA push force requirements

Finishes:

- Brushed Stainless Steel

SFT-W60 Kits Include:

- 1 ea **SC-BAR/** Stainless Steel Track with Two Soft Close Devices
- **BRACKET2** Stainless Steel Wall Brackets
- 2 ea **SC-62** Stainless Steel Hangers
- 1 ea **102SS-KIT** Stainless Steel Guide
- 2 ea **STOP2** Stainless Steel Stops Mounting Hardware
- 2 ea **SC-TRG** Soft Close Activators

Standard Kit Sizes			
PART NUMBER	MATERIAL	TRACK LENGTH	DOOR WIDTH
SFT-W60/6	304 Stainless Steel	78 ³ / ₄ "	36"
SFT-W60/8	304 Stainless Steel	98 ⁷ / ₁₆ "	48"

Options:

- Hardware Pack (One Door) **SC-W60H/PACK**
- Mortise Guides **102N**
- Polypropylene Guide Rail **EPD3BL** For Use With 102N and 102SS-KIT
- 5/8" Spacer **BLD-SPACER-58** Pack of 5 5/8" Spacer Recommended for use with 5/8" Gypsum Board When Mounting Track Directly to Gypsum Board

800-824-3018 | www.pemko.com

Check the web site for the up-to-date catalog

Copyright © 2015-2024, ASSA ABLOY Accessories and Door Controls Group, Inc., an ASSA ABLOY Group company. All rights reserved. Reproduction in whole or in part without the express written permission of ASSA ABLOY Accessories and Door Controls Group, Inc. is prohibited.

PEMCO
ASSA ABLOY

Experience a safer
and more open world

STAINLESS STEEL SLIDING TRACK HARDWARE SYSTEM

W70 SERIES FOR WOOD DOORS

For Sliding Panels up to 240 lbs.



Shown with Optional Stop. Part number: STOP1

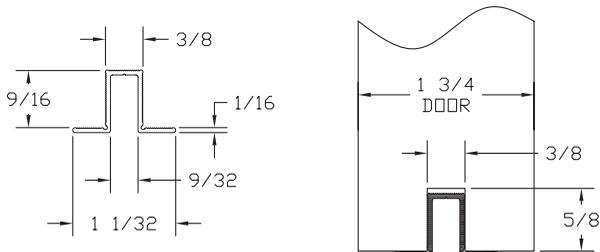
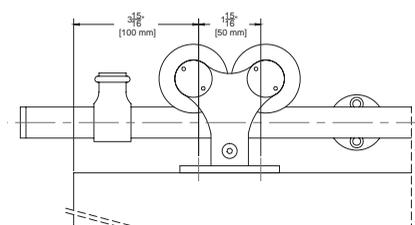
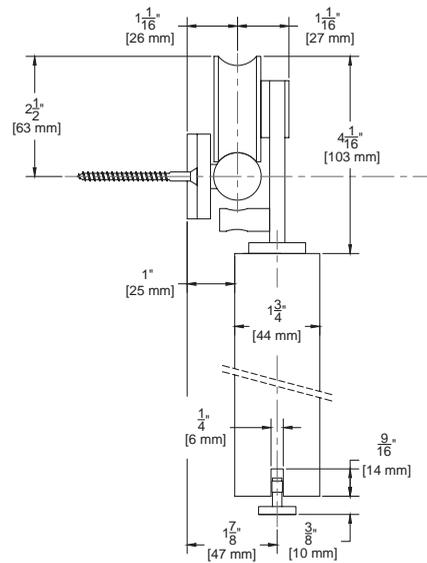

NOTE: Alternate route dimension when using optional EPD3BL

Configurations:

- Single
- Bi-parting

Installations:

- Side Wall Mount (only)

Features:

- Made of 304 stainless steel
- Nylon coated stainless steel wheel for smooth operation
- 240 lb. panel capacity
- 5 year warranty
- Meets ADA push force requirements

Finishes:

- Brushed Stainless Steel (W70)
- Black Powder Coated Stainless Steel (W70D)
- Polished Stainless Steel (W70P)

W70 Kits Include:

- 1 ea **BAR/** Stainless Steel Track
- **BRACKET2** Stainless Steel Wall Brackets
- 2 ea **WD72** Stainless Steel Hangers
- 1 ea **102SS-KIT** Stainless Steel Guide
- 2 ea **STOP2** Stainless Steel Stops Mounting Hardware

NOTE: If ordering individual parts in the optional Black Powder Coat, Polished finishes be sure to include a prefix "D" for Black Powder Coat, or "P" for Polished Stainless

Standard Kit Sizes			
PART NUMBER	MATERIAL	TRACK LENGTH	DOOR WIDTH
W70/6	304 Stainless Steel	78 ³ / ₄ "	36"
W70/8	304 Stainless Steel	98 ⁷ / ₁₆ "	48"
W70D/6	Black Powder Coated Stainless Steel	78 ³ / ₄ "	36"
W70D/8	Black Powder Coated Stainless Steel	98 ⁷ / ₁₆ "	48"
W70P/6	304 Polished Stainless Steel	78 ³ / ₄ "	36"
W70P/8	304 Polished Stainless Steel	98 ⁷ / ₁₆ "	48"

Custom lengths are available. Please contact the factory to order.

Options:

- Hardware Pack (One Door)
- Alternate Stop
- Mortise Guides
- Polypropylene Guide Rail
- 5/8" Spacer

W70_H/PACK

STOP1

102N

EPD3BL For Use With 102N

BLD-SPACER-58 Pack of 5 5/8" Spacer
Recommended for use with 5/8" Gypsum Board
When Mounting Track Directly to Gypsum Board



Experience a safer and more open world

STAINLESS STEEL SLIDING TRACK HARDWARE SYSTEM

W80 SERIES FOR WOOD DOORS

For Sliding Panels up to 176 lbs.

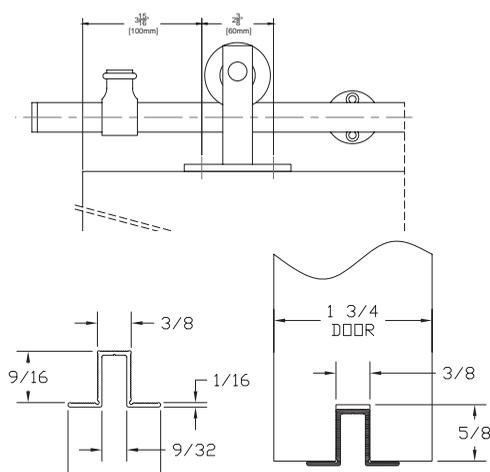
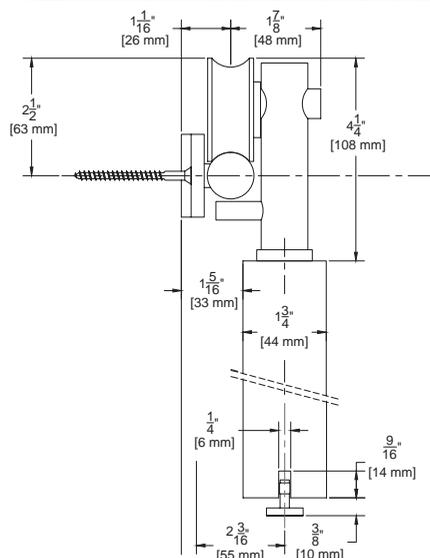
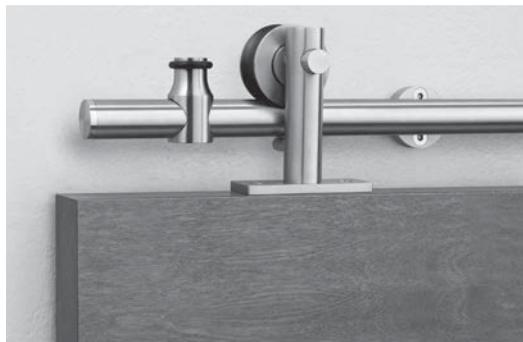

NOTE: Alternate route dimension when using optional EPD3BL

Configurations:

- Single
- Bi-parting

Installations:

- Side Wall Mount (only)

Features:

- Made of 304 stainless steel
- Nylon coated stainless steel wheel for smooth operation
- 176 lb. panel capacity
- 5 year warranty
- Meets ADA push force requirements

Finishes:

- Brushed Stainless Steel (W80)
- Black Powder Coated Stainless Steel (W80D)
- Polished Stainless Steel (W80P)

W80 Kits Include:

- 1 ea **BAR_** Stainless Steel Track
- **BRACKET2** Stainless Steel Wall Brackets
- 2 ea **WD82** Stainless Steel Hangers
- 1 ea **102SS-KIT** Stainless Steel Guide
- 2 ea **STOP2** Stainless Steel Stops Mounting Hardware

NOTE: If ordering individual parts in the optional Black Powder Coat, Polished finishes be sure to include a prefix "D" for Black Powder Coat, or "P" for Polished Stainless

Standard Kit Sizes			
PART NUMBER	MATERIAL	TRACK LENGTH	DOOR WIDTH
W80/6	304 Stainless Steel	78 ³ / ₄ "	36"
W80/8	304 Stainless Steel	98 ⁷ / ₁₆ "	48"
W80D/6	Black Powder Coated Stainless Steel	78 ³ / ₄ "	36"
W80D/8	Black Powder Coated Stainless Steel	98 ⁷ / ₁₆ "	48"
W80P/6	304 Polished Stainless Steel	78 ³ / ₄ "	36"
W80P/8	304 Polished Stainless Steel	98 ⁷ / ₁₆ "	48"

Custom lengths are available. Please contact the factory to order.

Options:

- Hardware Pack (One Door)
- Mortise Guides
- Polypropylene Guide Rail
- 5/8" Spacer

W80_H/PACK

102N

EPD3BL For Use With 102N

BLD-SPACER-58 Pack of 5 5/8" Spacer Recommended for use with 5/8" Gypsum Board When Mounting Track Directly to Gypsum Board

800-824-3018 | www.pemko.com

Check the web site for the up-to-date catalog

Copyright © 2015-2024, ASSA ABLOY Accessories and Door Controls Group, Inc., an ASSA ABLOY Group company. All rights reserved. Reproduction in whole or in part without the express written permission of ASSA ABLOY Accessories and Door Controls Group, Inc. is prohibited.

PEMKO
ASSA ABLOY

Experience a safer
and more open world

STAINLESS STEEL SLIDING TRACK HARDWARE SYSTEM

W90 SERIES FOR WOOD DOORS

For Sliding Panels up to 176 lbs.

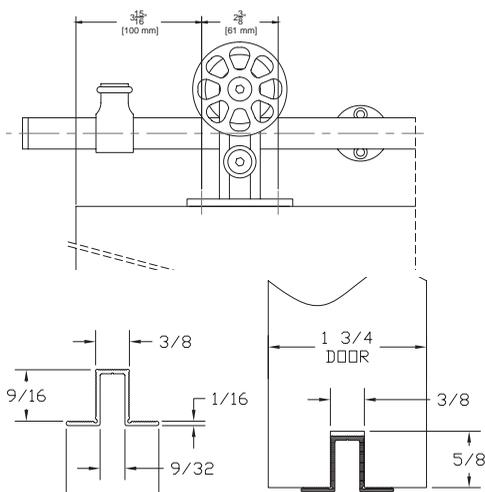
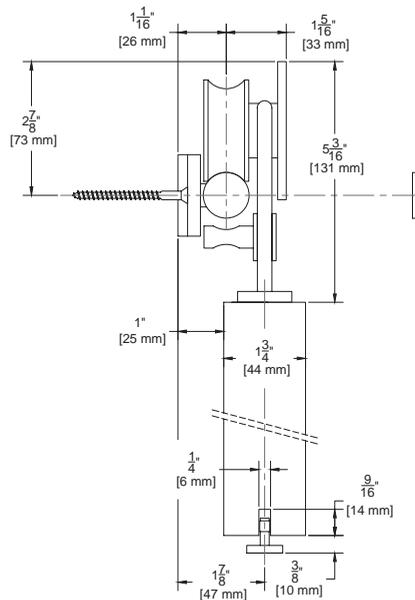
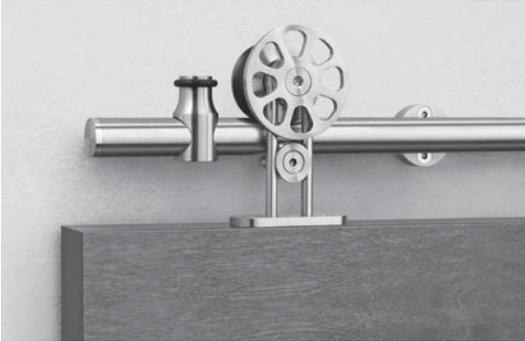

NOTE: Alternate route dimension when using optional EPD3BL



Experience a safer and more open world

Configurations:

- Single
- Bi-parting

Features:

- Made of 304 stainless steel
- Nylon coated stainless steel wheel for smooth operation
- 176 lb. panel capacity
- 5 year warranty
- Meets ADA push force requirements

Finishes:

- Brushed Stainless Steel (W90)
- Black Powder Coated Stainless Steel (W90D)

Installations:

- Side Wall Mount (only)

W90 Kits Include:

- 1 ea **BAR/** Stainless Steel Track
- **BRACKET2** Stainless Steel Wall Brackets
- 2 ea **WD92** Stainless Steel Hangers
- 1 ea **102SS-KIT** Stainless Steel Guide
- 2 ea **STOP2** Stainless Steel Stops Mounting Hardware

NOTE: If ordering individual parts in the optional Black Powder Coat, be sure to include a prefix "D" for Black Powder Coat

Standard Kit Sizes			
PART NUMBER	MATERIAL	TRACK LENGTH	DOOR WIDTH
W90/6	304 Stainless Steel	78 ³ / ₄ "	36"
W90/8	304 Stainless Steel	98 ⁷ / ₁₆ "	48"
W90D/6	Black Powder Coated Stainless Steel	78 ³ / ₄ "	36"
W90D/8	Black Powder Coated Stainless Steel	98 ⁷ / ₁₆ "	48"

Custom lengths are available. Please contact the factory to order.

Options:

- Hardware Pack (One Door) **W90_H/PACK**
- Mortise Guides **102N**
- Polypropylene Guide Rail **EPD3BL** For Use With 102N
- 5/8" Spacer **BLD-SPACER-58** Pack of 5 5/8" Spacer Recommended for use with 5/8" Gypsum Board When Mounting Track Directly to Gypsum Board

STAINLESS STEEL SLIDING TRACK HARDWARE SYSTEM

W100 SERIES FOR WOOD DOORS

For Sliding Panels up to 198 lbs.

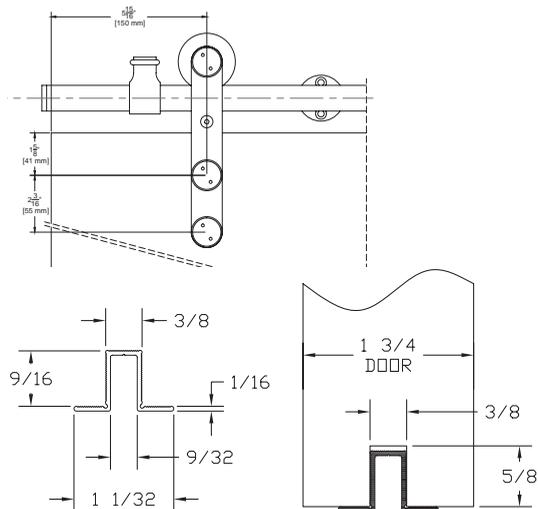
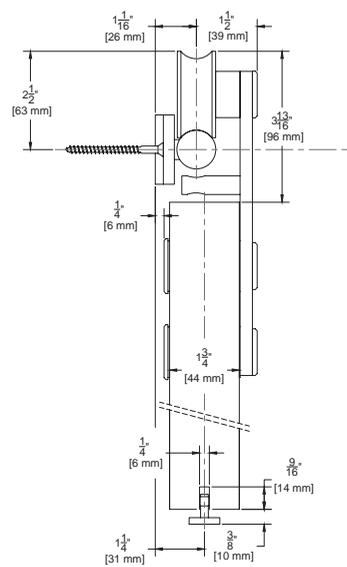

NOTE: Alternate route dimension when using optional EPD3BL

Configurations:

- Single
- Bi-parting

Installations:

- Side Wall Mount (only)

Features:

- Made of 304 stainless steel
- Nylon coated stainless steel wheel for smooth operation
- 198 lb. panel capacity
- 5 year warranty
- Meets ADA push force requirements

Finishes:

- Brushed Stainless Steel (W100)
- Black Powder Coated Stainless Steel (W100D)
- Polished Stainless Steel (W100P)

W100 Kits Include:

- 1 ea **BAR/_** Stainless Steel Track
- **BRACKET2** Stainless Steel Wall Brackets
- 2 ea **WD111** Stainless Steel Hangers
- 1 ea **102SS-KIT** Stainless Steel Guide
- 2 ea **STOP2** Stainless Steel Stops Mounting Hardware

NOTE: If ordering individual parts in the optional Black Powder Coat, Polished finishes be sure to include a prefix "D" for Black Powder Coat, or "P" for Polished Stainless

Standard Kit Sizes			
PART NUMBER	MATERIAL	TRACK LENGTH	DOOR WIDTH
W100/6	304 Stainless Steel	78 ³ / ₄ "	36"
W100/8	304 Stainless Steel	98 ⁷ / ₁₆ "	48"
W100D/6	Black Powder Coated Stainless Steel	78 ³ / ₄ "	36"
W100D/8	Black Powder Coated Stainless Steel	98 ⁷ / ₁₆ "	48"
W100P/6	304 Polished Stainless Steel	78 ³ / ₄ "	36"
W100P/8	304 Polished Stainless Steel	98 ⁷ / ₁₆ "	48"

Custom lengths are available. Please contact the factory to order.

Options:

- Hardware Pack (One Door)
- Mortise Guides
- Polypropylene Guide Rail
- 5/8" Spacer

W100_H/PACK

102N

EPD3BL For Use With 102N

BLD-SPACER-58 Pack of 5 5/8" Spacer Recommended for use with 5/8" Gypsum Board When Mounting Track Directly to Gypsum Board

800-824-3018 | www.pemko.com

Check the web site for the up-to-date catalog

Copyright © 2015-2024, ASSA ABLOY Accessories and Door Controls Group, Inc., an ASSA ABLOY Group company. All rights reserved. Reproduction in whole or in part without the express written permission of ASSA ABLOY Accessories and Door Controls Group, Inc. is prohibited.

PEMKO
ASSA ABLOY

Experience a safer
and more open world

STAINLESS STEEL SLIDING TRACK HARDWARE SYSTEM

G60 SERIES FOR GLASS DOORS

For Sliding Panels up to 198 lbs.

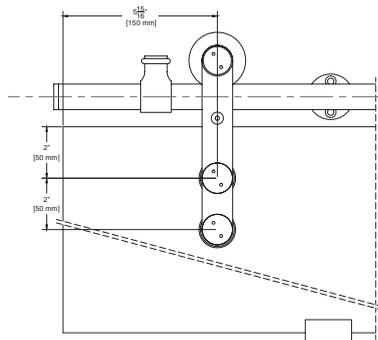
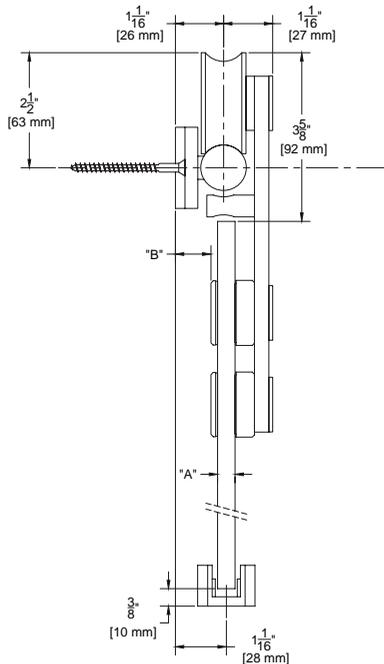

Glass Thickness "A"	Distance from Wall "B"
3/8"	3/4"
1/2"	5/8"

Configurations:

- Single
- Bi-parting

Installations:

- Side Wall Mount (only)

Features:

- Made of 304 stainless steel
- Nylon coated stainless steel wheel for smooth operation
- 198 lb. panel capacity
- 5 year warranty
- Meets ADA push force requirements

Finishes:

- Brushed Stainless Steel (G60)
- Black Powder Coated Stainless Steel (G60D)

G60 Kits Include:

- 1 ea **BAR/** Stainless Steel Track
- **BRACKET2** Stainless Steel Wall Brackets
- 2 ea **12** Stainless Steel Hangers
- 1 ea **GLASSGUIDE** Stainless Steel Guide
- 2 ea **STOP2** Stainless Steel Stops Mounting Hardware

NOTE: If ordering individual parts in the optional Black Powder Coat, be sure to include a suffix "D" for Black Powder Coat

Standard Kit Sizes			
PART NUMBER	MATERIAL	TRACK LENGTH	DOOR WIDTH
G60/6	304 Stainless Steel	78 ³ / ₄ "	36"
G60/8	304 Stainless Steel	98 ⁷ / ₁₆ "	48"
G60D/6	Black Powder Coated Stainless Steel	78 ³ / ₄ "	36"
G60D/8	Black Powder Coated Stainless Steel	98 ⁷ / ₁₆ "	48"

Custom lengths are available. Please contact the factory to order.

Options:

Hardware Pack (One Door) **G60_H/PACK**

5/8" Spacer

BLD-SPACER-58 Pack of 5 5/8" Spacer
Recommended for use with 5/8" Gypsum Board
When Mounting Track Directly to Gypsum Board



Experience a safer and more open world

800-824-3018 | www.pemko.com
Check the web site for the up-to-date catalog

Copyright © 2015-2024, ASSA ABLOY Accessories and Door Controls Group, Inc., an ASSA ABLOY Group company. All rights reserved. Reproduction in whole or in part without the express written permission of ASSA ABLOY Accessories and Door Controls Group, Inc. is prohibited.

STAINLESS STEEL SLIDING TRACK HARDWARE SYSTEM

G70 SERIES FOR GLASS DOORS

For Sliding Panels up to 240 lbs.

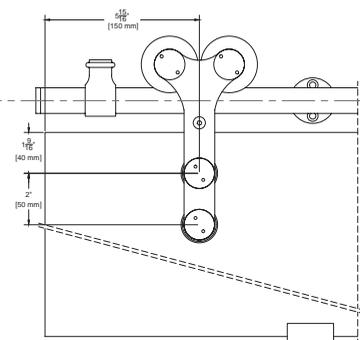
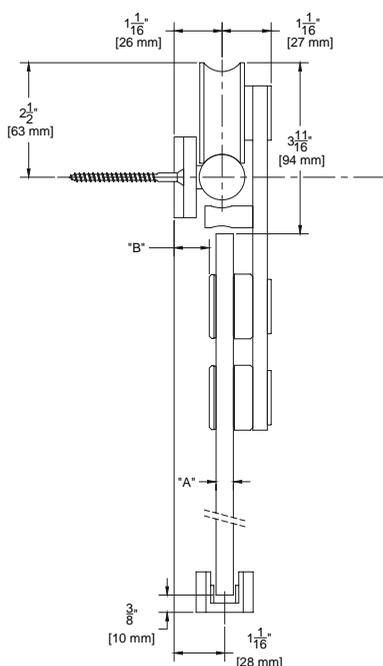

Glass Thickness "A"	Distance from Wall "B"
3/8"	3/4"
1/2"	5/8"

Configurations:

- Single
- Bi-parting

Installations:

- Side Wall Mount (only)

Features:

- Made of 304 stainless steel
- Nylon coated stainless steel wheel for smooth operation
- 240 lb. panel capacity
- 5 year warranty
- Meets ADA push force requirements

Finishes:

- Brushed Stainless Steel (G70)

G70 Kits Include:

- 1 ea **BAR/_** Stainless Steel Track
- **BRACKET2** Stainless Steel Wall Brackets
- 2 ea **32** Stainless Steel Hangers
- 1 ea **GLASSGUIDE** Stainless Steel Guide
- 2 ea **STOP2** Stainless Steel Stops Mounting Hardware

Standard Kit Sizes			
PART NUMBER	MATERIAL	TRACK LENGTH	DOOR WIDTH
G70/6	304 Stainless Steel	78 ³ / ₄ "	36"
G70/8	304 Stainless Steel	98 ⁷ / ₁₆ "	48"

Custom lengths are available. Please contact the factory to order.

Options:

Hardware Pack (One Door) **G70H/PACK**

Alternate Stop

STOP1

5/8" Spacer

BLD-SPACER-58 Pack of 5 5/8" Spacer Recommended for use with 5/8" Gypsum Board When Mounting Track Directly to Gypsum Board

BUILDERS SERIES FLAT TRACK SLIDING DOOR HARDWARE SYSTEM

BLD-FT-01 FOR WOOD DOORS

For Sliding Panels up to 240 lbs.

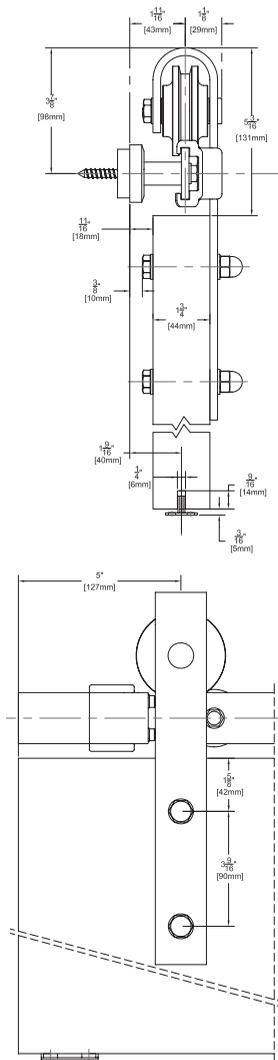

Configurations:

- Single
- Bi-parting

Installations:

- Side Wall Mount (only)

Features:

- Solid nylon wheel for smooth operation
- 240 lb. panel capacity
- Optional Soft Close
- 5 year warranty
- Meets ADA push force requirements

Finishes:

- Black Suede Powder Coated Steel (BLD-FT-01BSP)
- Industrial Steel Zinc Coated Steel (BLD-FT-01IS)

BLD-FT-01 Kits Include:

- 1 ea **BLD-FT_/_** Steel Flat Track
- 5 ea **BLD-99_/_** Steel Track Brackets
- 5 ea **BLD-88_/_** Steel Track Fasteners
- 2 ea **BLD-01_/_** Steel Strap Mount Hangers
- 2 ea **BLD-77** Anti-Rise Discs
- 1 ea **102N** Mortised Type Nylon Guide
- 2 ea **BLD-11_/_** Steel Track Stops Mounting Hardware

Standard Kit Sizes

PART NUMBER	MATERIAL	TRACK LENGTH	DOOR WIDTH
BLD-FT-01IS/6	Industrial Steel	72"	36"
BLD-FT-01IS/8	Industrial Steel	96"	48"
BLD-FT-01BSP/6	Black Suede Powder Coated Steel	72"	36"
BLD-FT-01BSP/8	Black Suede Powder Coated Steel	96"	48"

Custom lengths are available. Please contact the factory to order. Industrial Steel maximum track length is 8'. Lengths over 8' will be spliced by factory.

Options:

Thru-bolts for 1 3/8" thick doors 4 per door

Hardware Pack (One Door)

Side Wall Mortised Type Guide

Polypropylene Guide Rail

5/8" Spacer

BLD-97-__

BLD-FT01-__ /PACK

102WN-KIT

EPD3BL For Use With 102N

BLD-SPACER-58 Pack of 5 5/8" Spacer Recommended for use with 5/8" Gypsum Board When Mounting Track Directly to Gypsum Board

Soft Close available. See pages 269-271 for more information.

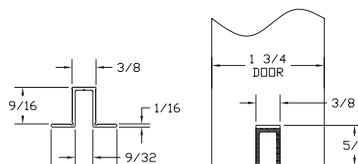

NOTE: Alternate route dimension when using optional EPD3BL



Experience a safer and more open world

BUILDERS SERIES FLAT TRACK SLIDING DOOR HARDWARE SYSTEM

BLD-FT-02 FOR WOOD DOORS

For Sliding Panels up to 240 lbs.

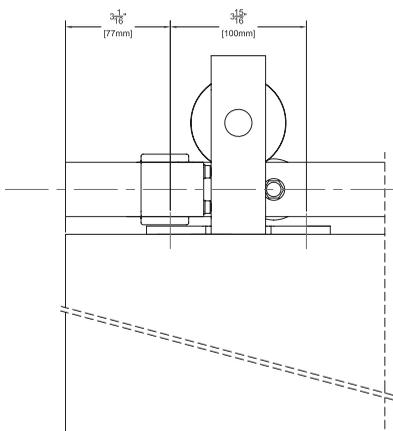
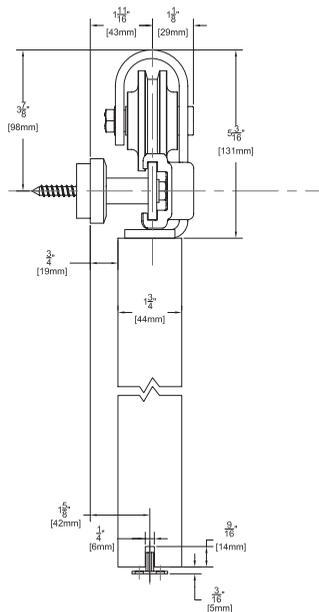
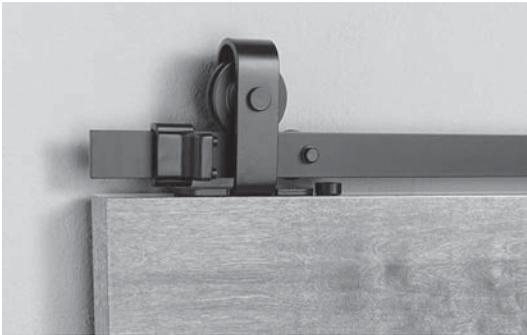

Configurations:

- Single
- Bi-parting

Installations:

- Side Wall Mount (only)

Features:

- Solid nylon wheel for smooth operation
- 240 lb. panel capacity
- Optional Soft Close
- 5 year warranty
- Meets ADA push force requirements

Finishes:

- Black Suede Powder Coated Steel (BLD-FT-02BSP)
- Industrial Steel Zinc Coated Steel (BLD-FT-02IS)

BLD-FT-02 Kits Include:

- 1 ea **BLD-FT-/_** Steel Flat Track
- 5 ea **BLD-99-/_** Steel Track Brackets
- 5 ea **BLD-88-/_** Steel Track Fasteners
- 2 ea **BLD-02-/_** Steel Top Mount Hangers
- 2 ea **BLD-77** Anti-Rise Discs
- 1 ea **102N** Mortised Type Nylon Guide
- 2 ea **BLD-11-/_** Steel Track Stops Mounting Hardware

Standard Kit Sizes

PART NUMBER	MATERIAL	TRACK LENGTH	DOOR WIDTH
BLD-FT-02IS/6	Industrial Steel	72"	36"
BLD-FT-02IS/8	Industrial Steel	96"	48"
BLD-FT-02BSP/6	Black Suede Powder Coated Steel	72"	36"
BLD-FT-02BSP/8	Black Suede Powder Coated Steel	96"	48"

Custom lengths are available. Please contact the factory to order. Industrial Steel maximum track length is 8'. Lengths over 8' will be spliced by factory.

Options:

See page 278

Hardware Pack (One Door) **BLD-FT02-_/PACK**

Side Wall Mortised Type Guide **102WN-KIT**

Polypropylene Guide Rail **EPD3BL** For Use With 102N

5/8" Spacer **BLD-SPACER-58** Pack of 5 5/8" Spacer

Recommended for use with 5/8" Gypsum Board When Mounting Track Directly to Gypsum Board

Soft Close available. See pages 269-271 for more information.

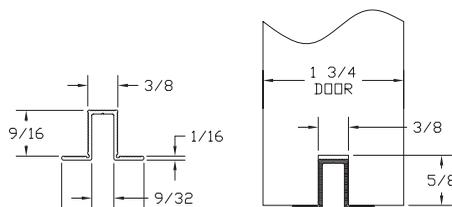

NOTE: Alternate route dimension when using optional EPD3BL

800-824-3018 | www.pemko.com

Check the web site for the up-to-date catalog

Copyright © 2015-2024, ASSA ABLOY Accessories and Door Controls Group, Inc., an ASSA ABLOY Group company. All rights reserved. Reproduction in whole or in part without the express written permission of ASSA ABLOY Accessories and Door Controls Group, Inc. is prohibited.

PEMKO
ASSA ABLOY

Experience a safer
and more open world

DESIGNER SERIES FLAT TRACK SLIDING DOOR HARDWARE SYSTEM

DSG-FT-05 FOR WOOD DOORS

For Sliding Panels up to 500 lbs.



Shown in Industrial Steel finish

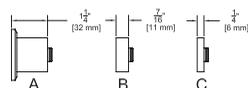
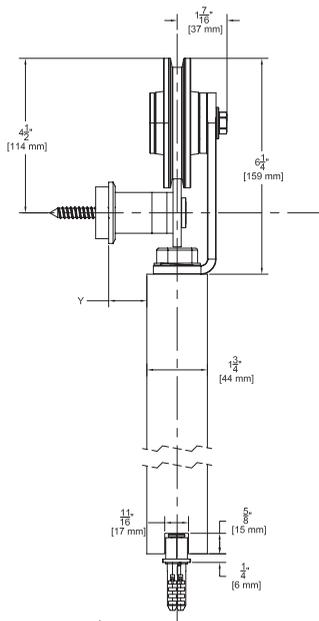

Wall Bracket Combination				
	A	A+C	A+B	A+B+C
"Y"	1/2"	3/4"	1"	1-1/4"

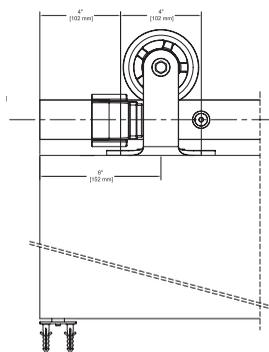

Experience a safer and more open world

Configurations:

- Single
- Bi-parting

Installations:

- Side Wall Mount (only)

Features:

- Solid steel wheel with a polymer resin contact surface for smooth operation
- 500 lb. panel capacity
- 5 year warranty

Finishes:

- Black Suede Powder Coated Steel (DSG-FT-05BSP)
- Industrial Steel Zinc Coated Steel (DSG-FT-05IS)
- Stainless Steel (DSG-FT-05SS)

DSG-FT-05 Kits include:

- 1 ea **DSG-FT_** Steel Flat Track
- 7 to 9 ea **DSG-100** Steel Track Brackets
- 7 to 9 ea **DSG-89** Steel Track Fasteners
- 2 ea **DSG-05-** Steel Top Mount Hangers
- 2 ea **DSG-78** Anti-Rise Blocks
- 1 ea **DSG-106** Mortised Type Roller Guide
- 2 ea **DSG-12-** Steel Track Stops Mounting Hardware

Standard Kit Sizes			
PART NUMBER	MATERIAL	TRACK LENGTH	DOOR WIDTH
DSG-FT-05IS/6	Industrial Steel	72"	36"
DSG-FT-05IS/8	Industrial Steel	96"	48"
DSG-FT-05BSP/6	Black Suede Powder Coated Steel	72"	36"
DSG-FT-05BSP/8	Black Suede Powder Coated Steel	96"	48"
DSG-FT-05SS/6	Stainless Steel	72"	36"
DSG-FT-05SS/8	Stainless Steel	96"	48"

Custom lengths are available. Please contact the factory to order. Industrial Steel maximum track length is 8'. Lengths over 8' will be spliced by factory.

Options:

- Hardware Pack (One Door)
- Side Wall Mortised Type Guide
- 5/8" Spacer

DSG-FT05-_/PACK

102WN-KIT

BLD-SPACER-58 Pack of 5 5/8" Spacer Recommended for use with 5/8" Gypsum Board When Mounting Track Directly to Gypsum Board

Soft Close available. See pages 269-271 for more information.

DESIGNER SERIES FLAT TRACK SLIDING DOOR HARDWARE SYSTEM

DSG-FT-06 FOR WOOD DOORS

For Sliding Panels up to 500 lbs.

Only for doors 1 1/2" to 2 1/4" thick.



Shown in Stainless Steel with a solid wheel. DGS-FT-06 in all other finishes have spoked wheels.

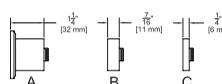
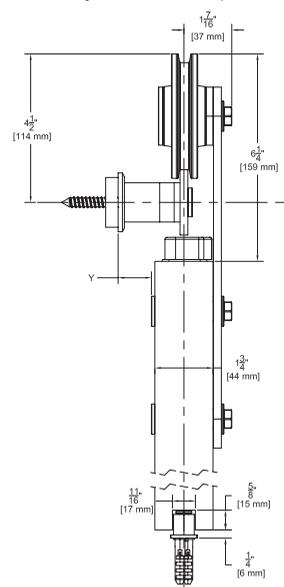

Wall Bracket Combination				
	A	A+C	A+B	A+B+C
"Y"	7/16"	11/16"	7/8"	1-1/8"

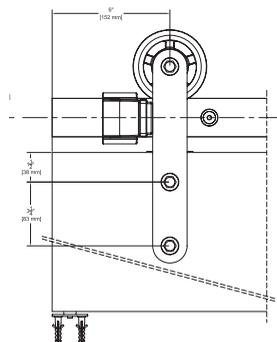

Configurations:

- Single
- Bi-parting

Installations:

- Side Wall Mount (only)

Features:

- Solid steel wheel with a polymer resin contact surface for smooth operation
- 500 lb. panel capacity
- 5 year warranty

Finishes:

- Black Black Suede Powder Coated Steel (DSG-FT-06BSP)
- Industrial Steel Zinc Coated Steel (DSG-FT-06IS)
- Stainless Steel (DSG-FT-06SS)

DSG-FT-06 Kits include:

- 1 ea **DSG-FT-/_** Steel Flat Track
- 7 to 9 ea **DSG-100-/_** Steel Track Brackets
- 7 to 9 ea **DSG-89-/_** Steel Track Fasteners
- 2 ea **DSG-06-/_** Steel Top Mount Hangers
- 2 ea **DSG-78** Anti-Rise Blocks
- 1 ea **DSG-106** Mortised Type Roller Guide
- 2 ea **DSG-12-/_** Steel Track Stops Mounting Hardware

Standard Kit Sizes

PART NUMBER	MATERIAL	TRACK LENGTH	DOOR WIDTH
DSG-FT-06IS/6	Industrial Steel	72"	36"
DSG-FT-06IS/8	Industrial Steel	96"	48"
DSG-FT-06BSP/6	Black Suede Powder Coated Steel	72"	36"
DSG-FT-06BSP/8	Black Suede Powder Coated Steel	96"	48"
DSG-FT-06SS/6	Stainless Steel	72"	36"
DSG-FT-06SS/8	Stainless Steel	96"	48"

Custom lengths are available. Please contact the factory to order. Industrial Steel maximum track length is 8'. Lengths over 8' will be spliced by factory.

Options:

- Hardware Pack (One Door)
- Side Wall Mortised Type Guide
- 5/8" Spacer

DSG-FT06-_/PACK 102WN-KIT

BLD-SPACER-58 Pack of 5 5/8" Spacer Recommended for use with 5/8" Gypsum Board when Mounting Track Directly to Gypsum Board

Soft Close available. See pages 269-271 for more information.

800-824-3018 | www.pemko.com

Check the web site for the up-to-date catalog

Copyright © 2015-2024, ASSA ABLOY Accessories and Door Controls Group, Inc., an ASSA ABLOY Group company. All rights reserved. Reproduction in whole or in part without the express written permission of ASSA ABLOY Accessories and Door Controls Group, Inc. is prohibited.



Experience a safer and more open world

SIMULTANEOUS ACTING SLIDING DOOR SYSTEM SIM 150 FOR 2 DOOR SYSTEMS

For Sliding Panels up to 176 lbs.

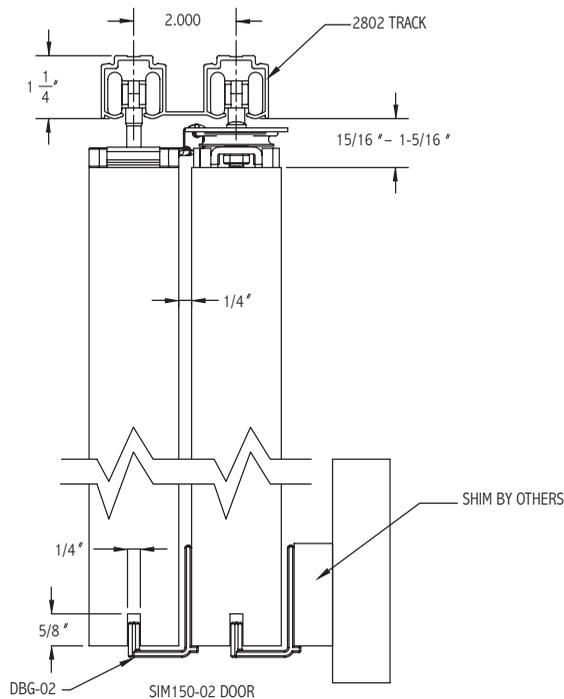
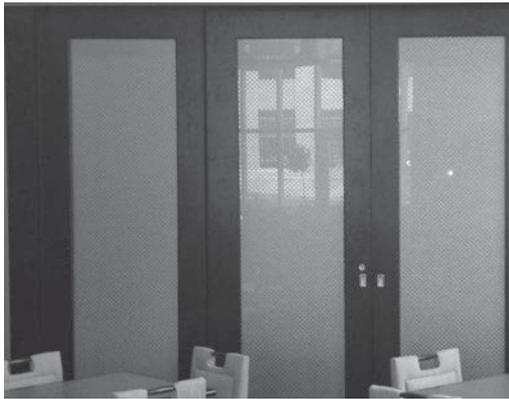

Alternate Route for EPD3BL

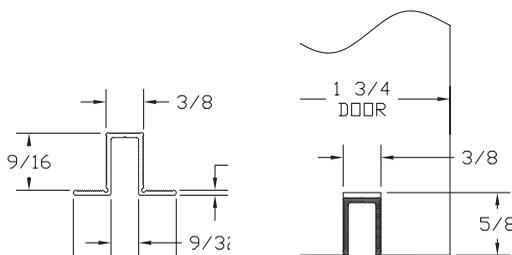

Experience a safer
and more open world

Configurations:

- Bi-part Telescoping

Installations:

- Overhead Mount

Features:

- Easy to install with self aligning components
- Telescoping panels glide along the track
- Doors retract into storage pockets when not in use
- 5 year warranty

Finishes:

- Clear (C)
- Dark Bronze (D)

Pulley System Kit Includes:

- Pre-Assembled Pulley System
- In-Track Stops and Hangers
- Door Bottom Guides
- Floor Stops, Back Stop and End Plates
- Installation Fasteners

Single Extrusion Aluminum Track must be ordered separately.

Specify door width when ordering. Default door overlap is 3". Any other overlap must be specified (Min. overlap is 2").

Note: All doors must be of equal width.

Pulley System Kits	
PART NUMBER	DOOR WIDTH
SIM150-2-LH/25-32	25" - 32"
SIM150-2-LH/33-40	33" - 40"
SIM150-2-LH/41-48	41" - 48"
SIM150-2-RH/25-32	25" - 32"
SIM150-2-RH/33-40	33" - 40"
SIM150-2-RH/41-48	41" - 48"

System Track Ordered Separately		
TRACK	FINISH	TRACK LENGTH
2802C	Clear	up to 147"
2802D	Dark	up to 185"

Options:

Lock Kit- includes lock with edge pull, and cup pull, **SIM150-LOCKKIT**

Bolt Kit- includes surface bolt, dust-proof strike, cup pull, and edge pull, **SIM150-BOLTKIT**

Snap-on Fascia Available **F134**

Polypropylene Guide Rail **EPD3BL**

SIMULTANEOUS ACTING SLIDING DOOR SYSTEM SIM 150 FOR 3 DOOR SYSTEMS

For Sliding Panels up to 176 lbs.

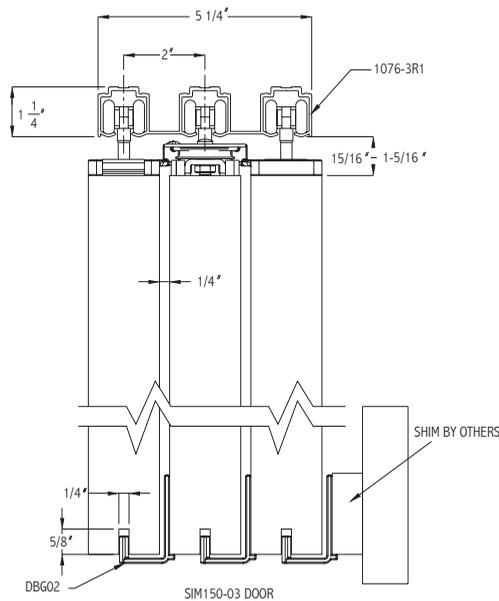

Alternate Route for EPD3BL

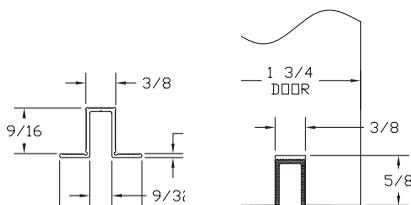

Configurations:

- Bi-part Telescoping

Installations:

- Overhead Mount

Features:

- Easy to install with self aligning components
- Telescoping panels glide along the track
- Doors retract into storage pockets when not in use
- 5 year warranty

Finishes:

- Clear (C)
- Dark Bronze (D)

Pulley System Kit Includes:

- Pre-Assembled Pulley System
- In-Track Stops and Hangers
- Door Bottom Guides
- Floor Stops, Back Stop and End Plates
- Installation Fasteners

Single Extrusion Aluminum Track must be ordered separately.

Specify door width when ordering. Default door overlap is 3". Any other overlap must be specified (Min. overlap is 2").

Note: All doors must be of equal width.

Pulley System Kits

PART NUMBER	DOOR WIDTH
SIM150-3-LH/25-32	25" - 32"
SIM150-3-LH/33-40	33" - 40"
SIM150-3-LH/41-48	41" - 48"
SIM150-3-RH/25-32	25" - 32"
SIM150-3-RH/33-40	33" - 40"
SIM150-3-RH/41-48	41" - 48"

System Track Ordered Separately

TRACK	FINISH	TRACK LENGTH
2803C and 280C	Clear	up to 144"
2803D and 280D	Dark	up to 144"

Options:

Lock Kit- includes lock with edge pull, and cup pull, **SIM150-LOCKKIT**

Bolt Kit- includes surface bolt, dust-proof strike, cup pull, and edge pull, **SIM150-BOLTKIT**

Snap-on Fascia Available **F134**

Polypropylene Guide Rail **EPD3BL**

800-824-3018 | www.pemko.com

Check the web site for the up-to-date catalog

Copyright © 2015-2024, ASSA ABLOY Accessories and Door Controls Group, Inc., an ASSA ABLOY Group company. All rights reserved. Reproduction in whole or in part without the express written permission of ASSA ABLOY Accessories and Door Controls Group, Inc. is prohibited.

PEMKO
ASSA ABLOY

Experience a safer
and more open world

CASCADING SLIDING DOOR SYSTEM

For Sliding Panels up to 200 lbs. each.



Note: All doors must be of equal width. Minimum overlap between doors is 2".

Cased Opening

NOTE: Aluminum "T" Guide **102PB** Shown Under Options Must be Ordered Separately for Fixed Panel in Cased Opening Application

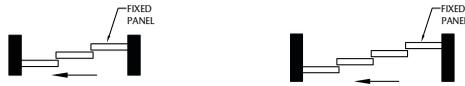

Pocket

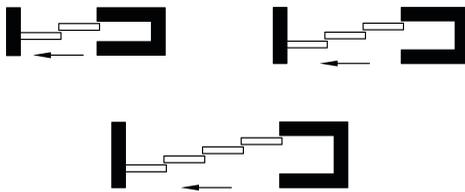

Side Wall Mount

NOTE: Side Wall track Brackets Shown Under Options Must be Ordered Separately for Side Wall Mount Openings



Configurations:

- Bi-part Telescoping
- Single Direction Telescoping

Features:

- Opening and closing of lead door results in the trailing doors to follow because of interlocking hardware at door top edges
- Easy to install with self aligning components on 1 3/4" and 1 3/8" thick doors
- Telescoping panels glide along the track
- Solid steel catches with rubber bumpers ensure durable yet quiet operation
- 200 lb. per door weight capacity
- 5 year warranty

Cascading Kit Includes:

- CAS-05** Catches - Mechanical Catch system - 2 Per Door
- 601H** - Track Stops - 2 Per Door
- H222R1** - Hangers - 2 Per Door
- DBG-02R1** - Door Bottom Guides - 1 Per Door
- TELS-23** - End Plates - 2 Per Door
- 2802C** - Single Extrusion - Dual Track
- 280C** - Single Extrusion - Single Track
- C1076-TC** - Track Connector for CAS200A-4/_ Kits
- EPD3-BL** - Polypropylene Guide Rails - 1 Per Door
- WRENCH14** - 1 Hanger Wrench Hardware Fasteners

Cascading System Kits			
PART NUMBER	TRACK LENGTH	# OF DOORS	INSTALLATION
CAS200A-2/6	6'	2	Pocket Side Wall
CAS200A-2/8	8'	2	
CAS200A-2/10	10'	2	
CAS200A-2/12	12'	2	
CAS200A-3/8	8'	3	Pocket Cased Opening Side Wall
CAS200A-3/10	10'	3	
CAS200A-3/12	12'	3	
CAS200A-3/16	16'	3	
CAS200A-4/8	8'	4	Pocket Cased Opening
CAS200A-4/10	10'	4	
CAS200A-4/12	12'	4	
CAS200A-4/16	16'	4	

For special number of doors and for dark bronze track, please contact Technical Support for more information

Options:

Lock Kit	SIM150-LOCKKIT includes lock with edge pull and cup pull
Bolt Kit	SIM150-BOLTKIT includes surface bolt, dust-proof strike, cup pull, and edge pull
Fascia	F134C Snap-on Fascia
Splice Kit	C1076-2SPLKIT for use with Bi-Parting systems and 2802C Track C1076-3SPLKIT for use with Bi-Parting systems and 2803C Track
Back Stop	TELS-25 for use with pocket systems when no access to in track stops in pocket
Aluminium "T" Guide	102PB for use with fixed panel in cased opening applications
Side Wall Track Bracket	2812KIT for use with 2802C Track (1 for every 12" of track) 2813KIT for use with 2803C Track (1 for every 12" of track)
Side Wall Joining Bracket	2813-5KIT for use with Side Wall Bi-Parting systems and 2803C Track

PEMKO
ASSA ABLOY

Experience a safer and more open world

PRIVACY BARN DOOR LOCK

PEMKO SDL SERIES FOR SURFACE MOUNTED SLIDING DOORS

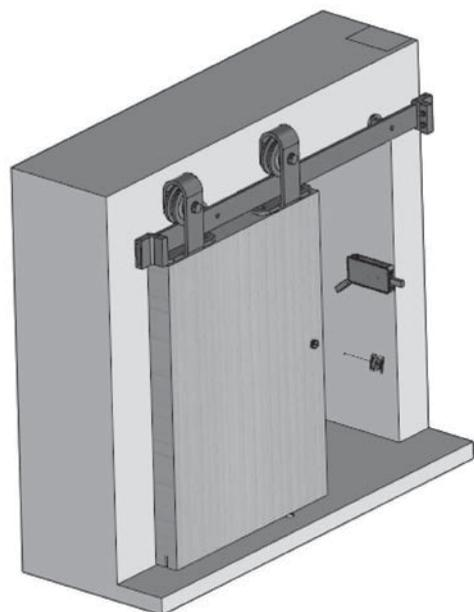
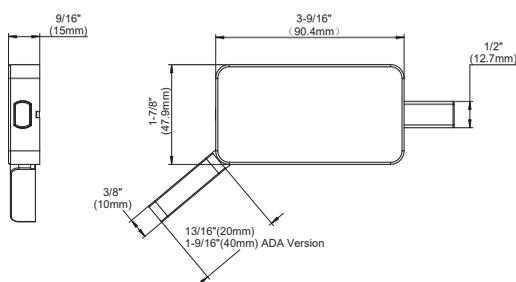

NOTE: For doors with 3/8" - 3/4" clearance between the wall or frame & door face

Configurations:

- Single

Installations:

- Side Wall Mount (only)
- For Side Wall Mounted Sliding Door Openings only
- New Construction
- Retro
- ADA

Features:

- Quick and easy installation
- Handing is reversible in the field
- ADA option available
- Privacy Function
- Includes Emergency Release Key
- Doors can be prepped in the field
- 5 year warranty

Finishes:

- Brushed Stainless Steel
- Polished Stainless Steel
- Black Graphite
- Contact factory if custom finish is required for more information

Standard Kit Sizes		
PART NUMBER	MATERIAL	ADA COMPLIANT
SDL32D	Brushed Stainless	
SDL32	Polished Stainless	
SDL19	Black Graphite	
SDL32D-ADA	Brushed Stainless	•
SDL32-ADA	Polished Stainless	•
SDL19-ADA	Black Graphite	•

Compatible with the following Pemko sliding door kits:

- W60 Series
- W70 Series (with 3/8" to 3/4" clearance)
- W80 Series (with 3/8" to 3/4" clearance)
- W90 Series (with 3/8" to 3/4" clearance)
- W100 Series
- Side Wall Box Track Series (SWT)
- BLD Flat Track Series
- DSG Flat Track Series (with 3/8" to 3/4" clearance)

800-824-3018 | www.pemko.com

Check the web site for the up-to-date catalog

Copyright © 2015-2024, ASSA ABLOY Accessories and Door Controls Group, Inc., an ASSA ABLOY Group company. All rights reserved. Reproduction in whole or in part without the express written permission of ASSA ABLOY Accessories and Door Controls Group, Inc. is prohibited.



Experience a safer and more open world

OPTIONS & ACCESSORIES

A visual guide to various parts

Mounting Brackets



281
(Sold in 5 packs, PC2815)



2812

Fascia



F134

End plates



K134EP

Stops



TELS-14KIT

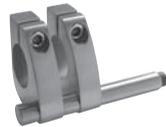

STOP1
W70 and G70 Kits only



PFBS

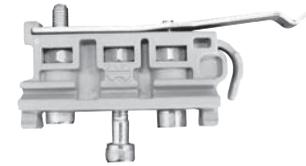

601H

Guides



102N



PFBG-4



106R/94



102WA



PFBG-8



106N/94

Pulls and Flush Bolts



503SF



FB150SS

Hardware Kits



Folding
HF2/100 Pack

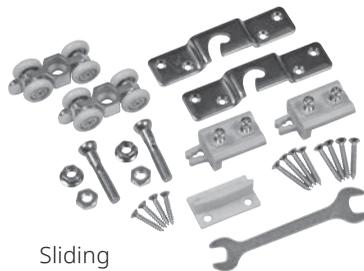

Sliding
H200PACK

Bottom Channel



94A



2802BT



971A

Privacy Seals



PEMKOSFSET1



PEMKOSFSET2



PEMKOSFSET3



PEMKOSFSET4



PEMKOSFSET5

For more information, see page 196

PEM KO
ASSA ABLOY

Experience a safer
and more open world

SOFT CLOSE FOR PEMKO BOX TRACK SYSTEMS

For Pemko H200, H180, SHS80, HBP200, and Side Wall Track (SWT) systems

Minimum Door Width 28" When Using Dual or Single Devices.

For doors weighing 88-132 lbs.		For doors weighing 133-176 lbs.	
ITEM #	DESCRIPTION	ITEM #	DESCRIPTION
H180 /6-1411-1	H180 6' Single Device	H180 /6-1413-1	H180 6' Single Device
H180 /8-1411-1	H180 8' Single Device	H180 /8-1413-1	H180 8' Single Device
H180 /10-1411-1	H180 10' Single Device	H180 /10-1413-1	H180 10' Single Device
H180 /12-1411-1	H180 12' Single Device	H180 /12-1413-1	H180 12' Single Device
H180 /6-1411-2	H180 6' Dual Devices	H180 /6-1413-2	H180 6' Dual Devices
H180 /8-1411-2	H180 8' Dual Devices	H180 /8-1413-2	H180 8' Dual Devices
H180 /10-1411-2	H180 10' Dual Devices	H180 /10-1413-2	H180 10' Dual Devices
H180 /12-1411-2	H180 12' Dual Devices	H180 /12-1413-2	H180 12' Dual Devices
SHS80 /6-1411-1	SHS80 6' Single Device	SHS80 /6-1413-1	SHS80 6' Single Device
SHS80 /8-1411-1	SHS80 8' Single Device	SHS80 /8-1413-1	SHS80 8' Single Device
SHS80 /6-1411-2	SHS80 6' Dual Devices	SHS80 /6-1413-2	SHS80 6' Dual Devices
SHS80 /8-1411-2	SHS80 8' Dual Devices	SHS80 /8-1413-2	SHS80 8' Dual Devices
H200 /6-1411-1	H200 6' Single Device	H200 /6-1413-1	H200 6' Single Device
H200 /8-1411-1	H200 8' Single Device	H200 /8-1413-1	H200 8' Single Device
H200 /10-1411-1	H200 10' Single Device	H200 /10-1413-1	H200 10' Single Device
H200 /12-1411-1	H200 12' Single Device	H200 /12-1413-1	H200 12' Single Device
H200 /6-1411-2	H200 6' Dual Devices	H200 /6-1413-2	H200 6' Dual Devices
H200 /8-1411-2	H200 8' Dual Devices	H200 /8-1413-2	H200 8' Dual Devices
H200 /10-1411-2	H200 10' Dual Devices	H200 /10-1413-2	H200 10' Dual Devices
H200 /12-1411-2	H200 12' Dual Devices	H200 /12-1413-2	H200 12' Dual Devices
280 -SWTKIT/6-1411-1	280 -SWTKIT 6' Single Device	280 -SWTKIT/6-1413-1	280 -SWTKIT 6' Single Device
280 -SWTKIT/8-1411-1	280 -SWTKIT 8' Single Device	280 -SWTKIT/8-1413-1	280 -SWTKIT 8' Single Device
280 -SWTKIT/12-1411-1	280 -SWTKIT 12' One Device Per Door	280 -SWTKIT/12-1413-1	280 -SWTKIT 12' One Device per Door
280 -SWTKIT/6-1411-2	280 -SWTKIT 6' Dual Devices	280 -SWTKIT/6-1413-2	280 -SWTKIT 6' Dual Devices
280 -SWTKIT/8-1411-2	280 -SWTKIT 8' Dual Devices	280 -SWTKIT/8-1413-2	280 -SWTKIT 8' Dual Devices
280 -SWTKIT/12-1411-2	280 -SWTKIT 12' Two Devices Per Door	280 -SWTKIT/12-1413-2	280 -SWTKIT 12' Two Devices per Door
RF280 -SWTK/6-1411-1	RF280 -SWTK 6' Single Device	RF280 -SWTK/6-1413-1	RF280 -SWTK 6' Single Device
RF280 -SWTK/8-1411-1	RF280 -SWTK 8' Single Device	RF280 -SWTK/8-1413-1	RF280 -SWTK 8' Single Device
RF280 -SWTK/12-1411-1	RF280 -SWTK 12' One Device Per Door	RF280 -SWTK/12-1413-1	RF280 -SWTK 12' One Device per Door
RF280 -SWTK/6-1411-2	RF280 -SWTK 6' Dual Devices	RF280 -SWTK/6-1413-2	RF280 -SWTK 6' Dual Devices
RF280 -SWTK/8-1411-2	RF280 -SWTK 8' Dual Devices	RF280 -SWTK/8-1413-2	RF280 -SWTK 8' Dual Devices
RF280 -SWTK/12-1411-2	RF280 -SWTK 12' Two Devices Per Door	RF280 -SWTK/12-1413-2	RF280 -SWTK 12' Two Devices per Door
SF280 -SWTK/6-1411-1	SF280 -SWTK 6' Single Device	SF280 -SWTK/6-1413-1	SF280 -SWTK 6' Single Device
SF280 -SWTK/8-1411-1	SF280 -SWTK 8' Single Device	SF280 -SWTK/8-1413-1	SF280 -SWTK 8' Single Device
SF280 -SWTK/12-1411-1	SF280 -SWTK 12' One Device Per Door	SF280 -SWTK/12-1413-1	SF280 -SWTK 12' One Device per Door
SF280 -SWTK/6-1411-2	SF280 -SWTK 6' Dual Devices	SF280 -SWTK/6-1413-2	SF280 -SWTK 6' Dual Devices
SF280 -SWTK/8-1411-2	SF280 -SWTK 8' Dual Devices	SF280 -SWTK/8-1413-2	SF280 -SWTK 8' Dual Devices
SF280 -SWTK/12-1411-2	SF280 -SWTK 12' Two Devices Per Door	SF280 -SWTK/12-1413-2	SF280 -SWTK 12' Two Devices per Door
HBP200 /6-1411-1	HBP200 6' One Device Per Door	HBP200 /6-1413-1	HBP200 6' One Device Per Door
HBP200 /8-1411-1	HBP200 8' One Device Per Door	HBP200 /8-1413-1	HBP200 8' One Device Per Door
HBP200 /10-1411-1	HBP200 10' One Device Per Door	HBP200 /10-1413-1	HBP200 10' One Device Per Door
HBP200 /12-1411-1	HBP200 12' One Device Per Door	HBP200 /12-1413-1	HBP200 12' One Device Per Door
HBP200 /6-1411-2	HBP200 6' Two Devices Per Door	HBP200 /6-1413-2	HBP200 6' Two Devices Per Door
HBP200 /8-1411-2	HBP200 8' Two Devices Per Door	HBP200 /8-1413-2	HBP200 8' Two Devices Per Door
HBP200 /10-1411-2	HBP200 10' Two Devices Per Door	HBP200 /10-1413-2	HBP200 10' Two Devices Per Door
HBP200 /12-1411-2	HBP200 12' Two Devices Per Door	HBP200 /12-1413-2	HBP200 12' Two Devices Per Door

800-824-3018 | www.pemko.com

Check the web site for the up-to-date catalog

Copyright © 2015-2024, ASSA ABLOY Accessories and Door Controls Group, Inc., an ASSA ABLOY Group company. All rights reserved.
Reproduction in whole or in part without the express written permission of ASSA ABLOY Accessories and Door Controls Group, Inc. is prohibited.

PEMKO
ASSA ABLOY

Experience a safer
and more open world

SOFT CLOSE FOR PEMKO BOX TRACK SYSTEMS *(Continued)*

For Pemko H200, H180, SHS80, HBP200, and Side Wall Track (SWT) systems

Minimum Door Width 28" When Using Dual or Single Devices.

For doors weighing 177-200 lbs.

ITEM #	DESCRIPTION
H180 /6-1418-1	H180 6' Single Device
H180 /8-1418-1	H180 8' Single Device
H180 /10-1418-1	H180 10' Single Device
H180 /12-1418-1	H180 12' Single Device
H180 /6-1418-2	H180 6' Dual Devices
H180 /8-1418-2	H180 8' Dual Devices
H180 /10-1418-2	H180 10' Dual Devices
H180 /12-1418-2	H180 12' Dual Devices
SHS80 /6-1418-1	SHS80 6' Single Device
SHS80 /8-1418-1	SHS80 8' Single Device
SHS80 /6-1418-2	SHS80 6' Dual Devices
SHS80 /8-1418-2	SHS80 8' Dual Devices
H200 /6-1418-1	H200 6' Single Device
H200 /8-1418-1	H200 8' Single Device
H200 /10-1418-1	H200 10' Single Device
H200 /12-1418-1	H200 12' Single Device
H200 /6-1418-2	H200 6' Dual Devices
H200 /8-1418-2	H200 8' Dual Devices
H200 /10-1418-2	H200 10' Dual Devices
H200 /12-1418-2	H200 12' Dual Devices
280 -SWTKIT/6-1418-1	280 -SWTKIT 6' Single Device
280 -SWTKIT/8-1418-1	280 -SWTKIT 8' Single Device
280 -SWTKIT/12-1418-1	280 -SWTKIT 12' One Device Per Door
280 -SWTKIT/6-1418-2	280 -SWTKIT 6' Dual Devices
280 -SWTKIT/8-1418-2	280 -SWTKIT 8' Dual Devices
280 -SWTKIT/12-1418-2	280 -SWTKIT 12' Two Devices Per Door
RF280 -SWTK/6-1418-1	RF280 -SWTK 6' Single Device
RF280 -SWTK/8-1418-1	RF280 -SWTK 8' Single Device
RF280 -SWTK/12-1418-1	RF280 -SWTK 12' One Device Per Door
RF280 -SWTK/6-1418-2	RF280 -SWTK 6' Dual Devices
RF280 -SWTK/8-1418-2	RF280 -SWTK 8' Dual Devices
RF280 -SWTK/12-1418-2	RF280 -SWTK 12' Two Devices Per Door
SF280 -SWTK/6-1418-1	SF280 -SWTK 6' Single Device
SF280 -SWTK/8-1418-1	SF280 -SWTK 8' Single Device
SF280 -SWTK/12-1418-1	SF280 -SWTK 12' One Device Per Door
SF280 -SWTK/6-1418-2	SF280 -SWTK 6' Dual Devices
SF280 -SWTK/8-1418-2	SF280 -SWTK 8' Dual Devices
SF280 -SWTK/12-1418-2	SF280 -SWTK 12' Two Devices Per Door
HBP200 /6-1418-1	HBP200 6' One Device Per Door
HBP200 /8-1418-1	HBP200 8' One Device Per Door
HBP200 /10-1418-1	HBP200 10' One Device Per Door
HBP200 /12-1418-1	HBP200 12' One Device Per Door
HBP200 /6-1418-2	HBP200 6' Two Devices Per Door
HBP200 /8-1418-2	HBP200 8' Two Devices Per Door
HBP200 /10-1418-2	HBP200 10' Two Devices Per Door
HBP200 /12-1418-2	HBP200 12' Two Devices Per Door

PEMKO
ASSA ABLOY

Experience a safer
and more open world

SOFT CLOSE FOR PEMKO FLAT TRACK SYSTEMS

For Pemko Designer Series Flat Track Sliding Door Hardware

Minimum Door Width Using Single Device 15".

22" Minimum Door Width When Using Dual Devices.

For doors weighing 88 - 132 lbs.

ITEM #	DESCRIPTION
DSG-FT-03 /6-1411-1	DSG-FT-03 6' Single Soft Close Device
DSG-FT-03 /8-1411-1	DSG-FT-03 8' Single Soft Close Device
DSG-FT-03 /6-1411-2	DSG-FT-03 6' Dual Soft Close Device
DSG-FT-03 /8-1411-2	DSG-FT-03 8' Dual Soft Close Device
DSG-FT-04 /6-1411-1	DSG-FT-04 6' Single Soft Close Device
DSG-FT-04 /8-1411-1	DSG-FT-04 8' Single Soft Close Device
DSG-FT-04 /6-1411-2	DSG-FT-04 6' Dual Soft Close Devices
DSG-FT-04 /8-1411-2	DSG-FT-04 8' Dual Soft Close Devices
DSG-FT-05 /6-1411-1	DSG-FT-05 6' Single Soft Close Device
DSG-FT-05 /8-1411-1	DSG-FT-05 8' Single Soft Close Device
DSG-FT-05 /6-1411-2	DSG-FT-05 6' Dual Soft Close Devices
DSG-FT-05 /8-1411-2	DSG-FT-05 8' Dual Soft Close Devices
DSG-FT-06 /6-1411-1	DSG-FT-06 6' Single Soft Close Device
DSG-FT-06 /8-1411-1	DSG-FT-06 8' Single Soft Close Device
DSG-FT-06 /6-1411-2	DSG-FT-06 6' Dual Soft Close Devices
DSG-FT-06 /8-1411-2	DSG-FT-06 8' Dual Soft Close Devices

For doors weighing 133-176 lbs.

ITEM #	DESCRIPTION
DSG-FT-03 /6-1413-1	DSG-FT-03 6' Single Soft Close Device
DSG-FT-03 /8-1413-1	DSG-FT-03 8' Single Soft Close Device
DSG-FT-03 /6-1413-2	DSG-FT-03 6' Dual Soft Close Device
DSG-FT-03 /8-1413-2	DSG-FT-03 8' Dual Soft Close Device
DSG-FT-04 /6-1413-1	DSG-FT-04 6' Single Soft Close Device
DSG-FT-04 /8-1413-1	DSG-FT-04 8' Single Soft Close Device
DSG-FT-04 /6-1413-2	DSG-FT-04 6' Dual Soft Close Devices
DSG-FT-04 /8-1413-2	DSG-FT-04 8' Dual Soft Close Devices
DSG-FT-05 /6-1413-1	DSG-FT-05 6' Single Soft Close Device
DSG-FT-05 /8-1413-1	DSG-FT-05 8' Single Soft Close Device
DSG-FT-05 /6-1413-2	DSG-FT-05 6' Dual Soft Close Devices
DSG-FT-05 /8-1413-2	DSG-FT-05 8' Dual Soft Close Devices
DSG-FT-06 /6-1413-1	DSG-FT-06 6' Single Soft Close Device
DSG-FT-06 /8-1413-1	DSG-FT-06 8' Single Soft Close Device
DSG-FT-06 /6-1413-2	DSG-FT-06 6' Dual Soft Close Devices
DSG-FT-06 /8-1413-2	DSG-FT-06 8' Dual Soft Close Devices

For doors weighing 177-240 lbs.

ITEM #	DESCRIPTION
DSG-FT-03 /6-1418-1	DSG-FT-03 6' Single Soft Close Device
DSG-FT-03 /8-1418-1	DSG-FT-03 8' Single Soft Close Device
DSG-FT-03 /6-1418-2	DSG-FT-03 6' Dual Soft Close Device
DSG-FT-03 /8-1418-2	DSG-FT-03 8' Dual Soft Close Device
DSG-FT-04 /6-1418-1	DSG-FT-04 6' Single Soft Close Device
DSG-FT-04 /8-1418-1	DSG-FT-04 8' Single Soft Close Device
DSG-FT-04 /6-1418-2	DSG-FT-04 6' Dual Soft Close Devices
DSG-FT-04 /8-1418-2	DSG-FT-04 8' Dual Soft Close Devices
DSG-FT-05 /6-1418-1	DSG-FT-05 6' Single Soft Close Device
DSG-FT-05 /8-1418-1	DSG-FT-05 8' Single Soft Close Device
DSG-FT-05 /6-1418-2	DSG-FT-05 6' Dual Soft Close Devices
DSG-FT-05 /8-1418-2	DSG-FT-05 8' Dual Soft Close Devices
DSG-FT-06 /6-1418-1	DSG-FT-06 6' Single Soft Close Device
DSG-FT-06 /8-1418-1	DSG-FT-06 8' Single Soft Close Device
DSG-FT-06 /6-1418-2	DSG-FT-06 6' Dual Soft Close Devices
DSG-FT-06 /8-1418-2	DSG-FT-06 8' Dual Soft Close Devices

SOFT CLOSE FOR PEMKO FLAT TRACK SYSTEMS

For Pemko Builders Series Flat Track Sliding Door Hardware

Minimum Door Width Using Single Device 15".

22" Minimum Door Width When Using Dual Devices.

For doors weighing 88 - 132 lbs.

ITEM #	DESCRIPTION
BLD-FT-01 /6-1411-1	BLD-FT-01 6' Single Device
BLD-FT-01 /8-1411-1	BLD-FT-01 8' Single Device
BLD-FT-01 /6-1411-2	BLD-FT-01 6' Dual Devices
BLD-FT-01 /8-1411-2	BLD-FT-01 8' Dual Devices
BLD-FT-02 /6-1411-1	BLD-FT-02 6' Single Device
BLD-FT-02 /8-1411-1	BLD-FT-02 8' Single Device
BLD-FT-02 /6-1411-2	BLD-FT-02 6' Dual Devices
BLD-FT-02 /8-1411-2	BLD-FT-02 8' Dual Devices

For doors weighing 133-176 lbs.

ITEM #	DESCRIPTION
BLD-FT-01 /6-1413-1	BLD-FT-01 6' Single Device
BLD-FT-01 /8-1413-1	BLD-FT-01 8' Single Device
BLD-FT-01 /6-1413-2	BLD-FT-01 6' Dual Devices
BLD-FT-01 /8-1413-2	BLD-FT-01 8' Dual Devices
BLD-FT-02 /6-1413-1	BLD-FT-02 6' Single Device
BLD-FT-02 /8-1413-1	BLD-FT-02 8' Single Device
BLD-FT-02 /6-1413-2	BLD-FT-02 6' Dual Devices
BLD-FT-02 /8-1413-2	BLD-FT-02 8' Dual Devices

For doors weighing 177-240 lbs.

ITEM #	DESCRIPTION
BLD-FT-01 /6-1418-1	BLD-FT-01 6' Single Device
BLD-FT-01 /8-1418-1	BLD-FT-01 8' Single Device
BLD-FT-01 /6-1418-2	BLD-FT-01 6' Dual Devices
BLD-FT-01 /8-1418-2	BLD-FT-01 8' Dual Devices
BLD-FT-02 /6-1418-1	BLD-FT-02 6' Single Device
BLD-FT-02 /8-1418-1	BLD-FT-02 8' Single Device
BLD-FT-02 /6-1418-2	BLD-FT-02 6' Dual Devices
BLD-FT-02 /8-1418-2	BLD-FT-02 8' Dual Devices

SOFT CLOSE RETROFIT KITS

For Designer Series Systems

ITEM #	DESCRIPTION
DSG1411-1	Single Device 88-132 lbs.
DSG1411-2	Dual Devices 88-132 lbs.
DSG1413-1	Single Device 133-176 lbs.
DSG1413-2	Dual Devices 133-176 lbs.
DSG1418-1	Single Device 177-240 lbs.
DSG1418-2	Dual Devices 177-240 lbs.

Finishes: add IS for Industrial Steel finish
add BSP for Black Suede finish
add SS for Stainless Steel finish

For Builders Series Systems

ITEM #	DESCRIPTION
BLD1411-1	Single Device 88-132 lbs.
BLD1411-2	Dual Devices 88-132 lbs.
BLD1413-1	Single Device 133-176 lbs.
BLD1413-2	Dual Devices 133-176 lbs.
BLD1418-1	Single Device 177-240 lbs.
BLD1418-2	Dual Devices 177-240 lbs.

Finishes: add C for IS finish
add D for BSP finish

For Box Track Systems

ITEM #	DESCRIPTION
SC1411-1	Single Device 88-132 lbs.
SC1411-2	Dual Devices 88-132 lbs.
SC1413-1	Single Device 133-176 lbs.
SC1413-2	Dual Devices 133-176 lbs.
SC1418-1	Single Device 177-240 lbs.
SC1418-2	Dual Devices 177-240 lbs.

SOFT CLOSE POCKET FRAME KIT

PF134KIT must be ordered when using 1-3/4" thick doors in 2x4 stud constructed walls.

Wood 2x4 Stud Constructed Walls	Wood 2x6 Stud Constructed Walls	Metal 2x6 Stud Constructed Walls	Net Door Size	Options
SC-PF28200A7280	SC-PF28200A7280-2x6	SC-PF28200A7280-SP6	3'0" x 6'8"	PFAS84, PFCDKIT for Bi-Parting door openings
SC-PF28200A9680	SC-PF28200A9680-2x6	SC-PF28200A9680-SP6	4'0" x 6'8"	PFAS84, PFCDKIT for Bi-Parting door openings
SC-PF28200A7284	SC-PF28200A7284-2x6	SC-PF28200A7284-SP6	3'0" x 7'0"	PFAS88, PFCDKIT for Bi-Parting door openings
SC-PF28200A9684	SC-PF28200A9684-2x6	SC-PF28200A9684-SP6	4'0" x 7'0"	PFAS88, PFCDKIT for Bi-Parting door openings
SC-PF28200A7296	SC-PF28200A7296-2x6	SC-PF28200A7296-SP6	3'0" x 8'0"	PFAS100, PFCDKIT for Bi-Parting door openings
SC-PF28200A9696	SC-PF28200A9696-2x6	SC-PF28200A9696-SP6	4'0" x 8'0"	PFAS100, PFCDKIT for Bi-Parting door openings

800-824-3018 | www.pemko.com

Check the web site for the up-to-date catalog

Copyright © 2015-2024, ASSA ABLOY Accessories and Door Controls Group, Inc., an ASSA ABLOY Group company. All rights reserved.
Reproduction in whole or in part without the express written permission of ASSA ABLOY Accessories and Door Controls Group, Inc. is prohibited.

PEMKO
ASSA ABLOY

Experience a safer
and more open world



Experience a safer
and more open world

800-824-3018 | www.pemko.com
Check the web site for the up-to-date catalog

Copyright © 2015-2024, ASSA ABLOY Accessories and Door Controls Group, Inc., an ASSA ABLOY Group company. All rights reserved.
Reproduction in whole or in part without the express written permission of ASSA ABLOY Accessories and Door Controls Group, Inc. is prohibited.

RESIDENTIAL THRESHOLDS

CONTENTS:

Interlocking Thresholds and Caps	262
Interlocking Thresholds - Water Return.....	263
Interlocking Hooks.....	263
Adjustable Eco-V™ Top Thresholds	264
Eco-V™ Top Thresholds.....	264
Residential Saddles.....	264
Bumper Thresholds for Outswing Doors	265
Squareback Thresholds	265
Oak Thresholds.....	266
Sill Nosings	266
Adjustable Aluminum Top Sills.....	267
Adjustable Oak Top Sills.....	268
Outswing Adjustable Oak Top Sills.....	269
Residential All-Aluminum Adjustable Sills.....	269
Fixed Eco-V™ Top Residential Sills	270
Residential All-Aluminum Fixed Sills.....	270
Outswing Fixed Bumper Sills.....	271
Extenders For All Residential Sills.....	271

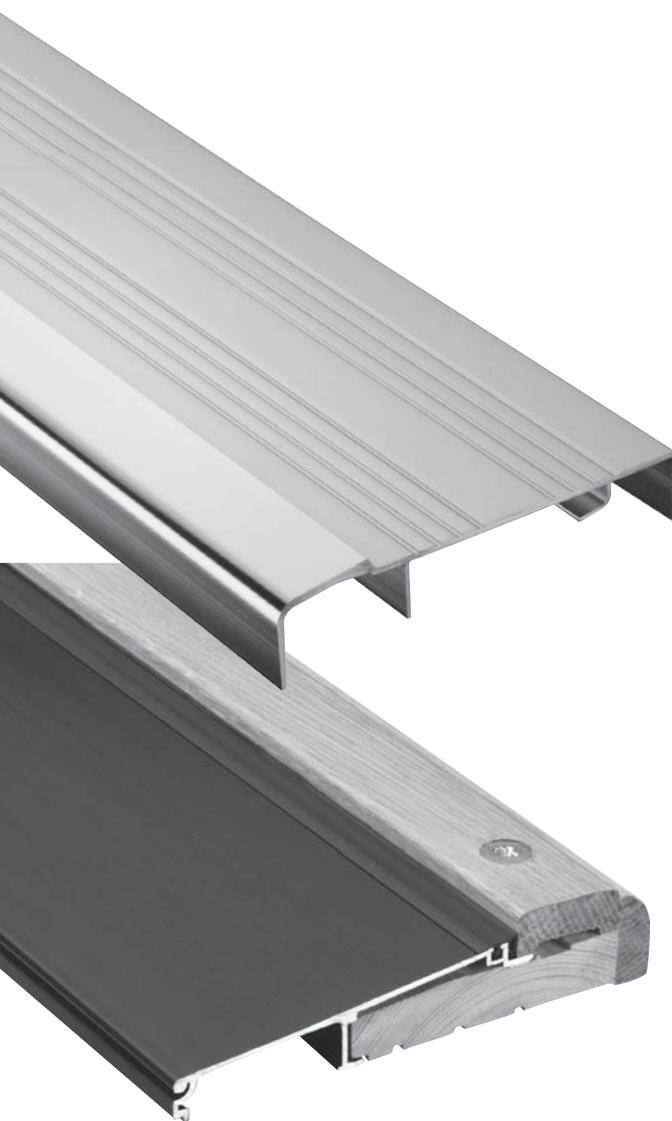

INDEX:

PRODUCT	PAGE	PRODUCT	PAGE	PRODUCT	PAGE
61	263	218OAK	266	74518	269
66.....	263	219.....	264	75518	269
101.....	262	219OAK	266	84514.....	270
108.....	262	249.....	264	85514.....	270
110.....	262	250	264	94518.....	267
114.....	262	324.....	266	94518_W	268
120.....	262	326.....	266	95518	267
136.....	263	327.....	266	95518_W	268
142.....	263	2051	265	EXT2.....	271
145.....	263	2052	265	EXT3.....	271
146.....	263	2053	265	EXT3/4.....	271
149.....	265	2054.....	265	N84518.....	270
206	264	2500W	266	N85518	270
208	264	3261	266	OS95518.....	269
212.....	264	8451	271		
218.....	264	8452	271		

800-824-3018 | www.pemko.com
Check the web site for the up-to-date catalog

Copyright © 2015-2024, ASSA ABLOY Accessories and Door Controls Group, Inc., an ASSA ABLOY Group company. All rights reserved.
Reproduction in whole or in part without the express written permission of ASSA ABLOY Accessories and Door Controls Group, Inc. is prohibited.

PEMKO
ASSA ABLOY

Experience a safer
and more open world

INTERLOCKING THRESHOLDS

- All interlocking thresholds (including water return types) and caps are furnished with #61 hooks and nails
- For alternate hooks, see following page

114_

AVAILABLE FINISHES: A, B, D

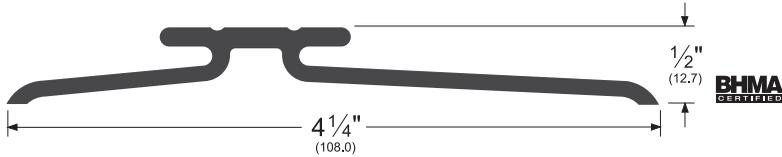

110_

AVAILABLE FINISHES: A, B, D

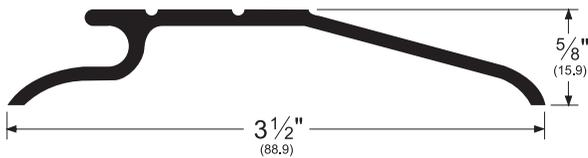

120_

AVAILABLE FINISHES: B

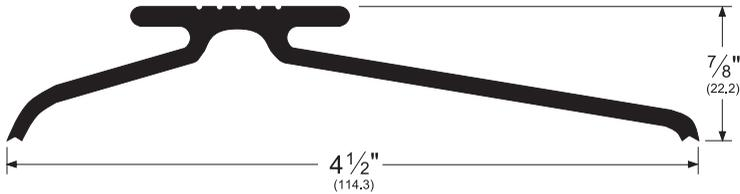

THRESHOLD CAPS

- Typically mounted on an existing saddle-type threshold to create an interlock with a J-hook or L-hook

101_

AVAILABLE FINISHES: A, B, D

ANSI: J34170

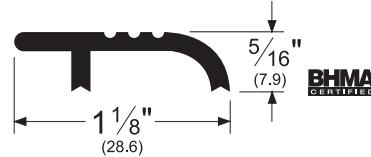

108_

AVAILABLE FINISH: B

ANSI: J14170

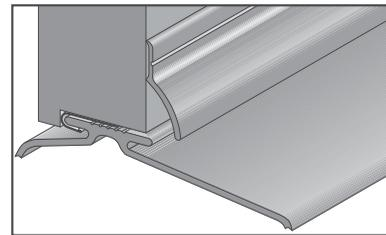
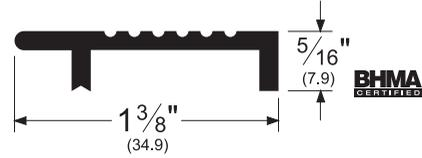

NOTE: Products shown in this section may not be drawn to scale.

AVAILABLE FINISHES FOR PRODUCTS SHOWN ON THIS PAGE

A (Mill Finish Aluminum) B (Mill Finish Extruded Bronze [Brass]) D (Dark Bronze Anodized)

PEMKO
ASSA ABLOY

Experience a safer
and more open world

INTERLOCKING THRESHOLDS - WATER RETURN

- Water return thresholds are designed to catch water which may blow or run under the door and return it to the outside through interior weep holes, down the sloped drain pan, and out exterior weep holes
- Product number for the aluminum water return pan is PAN
- Products are furnished with #61 hooks and nails

142_

AVAILABLE FINISHES: A, D

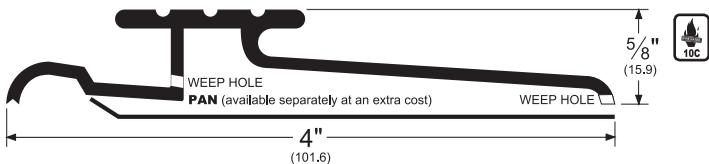

145_

AVAILABLE FINISHES: A, B, D

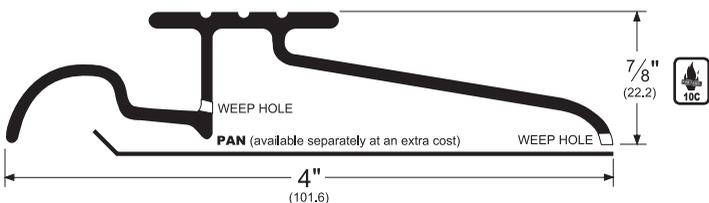

146_

AVAILABLE FINISHES: B

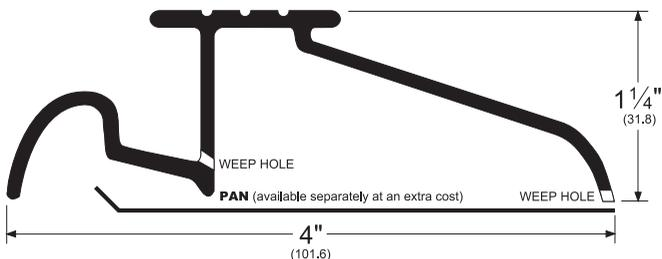

136_

AVAILABLE FINISHES: A, B, D

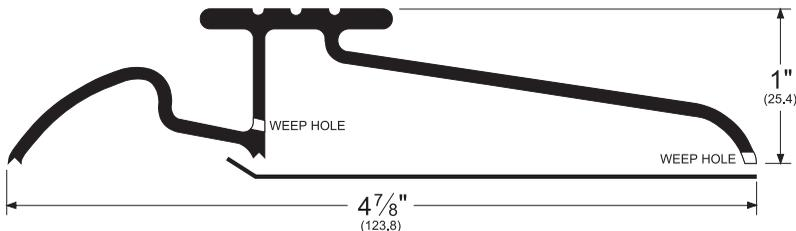

NOTE: Products shown in this section may not be drawn to scale.

AVAILABLE FINISHES FOR PRODUCTS SHOWN ON THIS PAGE

A (Mill Finish Aluminum) B (Mill Finish Extruded Bronze [Brass]) D (Dark Bronze Anodized)

For Hooks: B (Bronze) Z (Steel)

800-824-3018 | www.pemko.com

Check the web site for the up-to-date catalog

Copyright © 2015-2024, ASSA ABLOY Accessories and Door Controls Group, Inc., an ASSA ABLOY Group company. All rights reserved.

Reproduction in whole or in part without the express written permission of ASSA ABLOY Accessories and Door Controls Group, Inc. is prohibited.

Hooks

- When installed properly on bottom of door, hooks interlock with threshold for a superior seal
- When substituting #66 hook for #61 hooks, price will be increased accordingly. Contact Pemko Customer Service

66_

AVAILABLE FINISHES: A, D

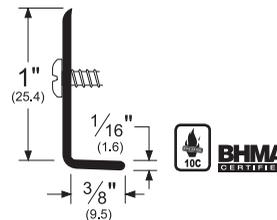

_61

AVAILABLE FINISHES: B, Z

.018 bronze

.015 steel

NOTE: B61 is roll form bronze metal

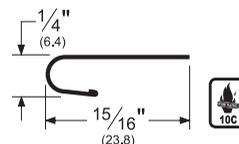

PEMKO
ASSA ABLOY

Experience a safer
and more open world

ADJUSTABLE ECO-V™ TOP THRESHOLDS

- Furnished with concealed, weather-sealed mounting screws and adjustment mechanism
- Eco-V™ seal adjusts to overcome swelling and/or shrinking of door and floor and eliminates need for shoe or sweep
- Furnished with Eco-V™ (V) insert. Gray replacement Eco-V™ is **PV64GR** (see Weatherization Products section)
- Eco-V™ replacement "foot" insert is **EV63GR**
- Pre-assembled for easy installation and adjustment

249_V

AVAILABLE FINISHES: A, D
AVAILABLE LENGTHS: **36", 72"**

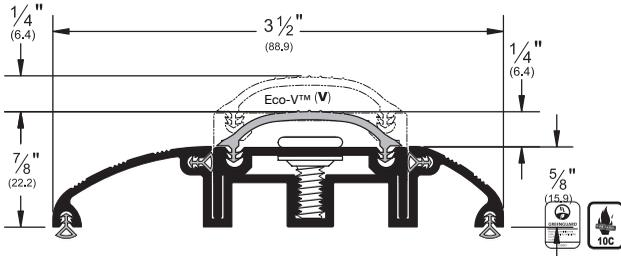

250_V

AVAILABLE FINISHES: A, D
AVAILABLE LENGTHS: **36", 72"**

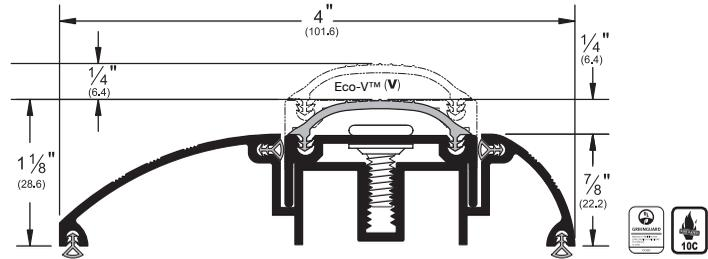

ECO-V™ TOP THRESHOLDS

- Eco-V™ (V) top creates a seal at the bottom of the door, eliminating the need for door sweeps or door shoes
- Eco-V™ feet replacement insert is **EV12GR**

206_V

AVAILABLE FINISHES: A, D
Gray replacement Eco-V™ is EV22GR
Black replacement Eco-V™ is EV22BL

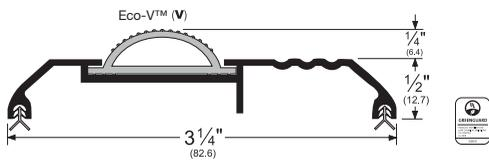

208_V

AVAILABLE FINISHES: A, D
Replacement Eco-V™ is EV15BL or EV15GR

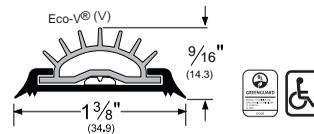

RESIDENTIAL SADDLES

- Use a door bottom shoe or sweep with these thresholds to seal out the elements
- Made of sturdy extruded aluminum
- Replacement Eco-V™ feet (where applicable) is **EV12GR**

212_

AVAILABLE FINISHES: A, D

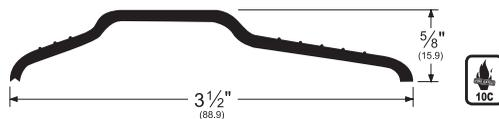

218_

AVAILABLE FINISHES: A, D, SN

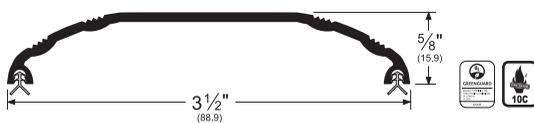

219_

AVAILABLE FINISHES: A, D, SN

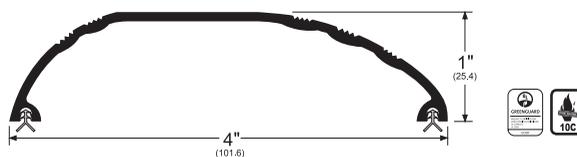

NOTE: Products shown in this section may not be drawn to scale.

AVAILABLE FINISHES FOR PRODUCTS SHOWN ON THIS PAGE
A (Mill Finish Aluminum) D (Dark Bronze Anodized) SN (Satin Nickel Anodized)

PEMKO
ASSA ABLOY

Experience a safer
and more open world

BUMPER THRESHOLDS FOR OUTSWING DOORS

- In the closed position, the door butts up to bumper seal on threshold creating a seal against the elements

149_T

AVAILABLE FINISHES: A, D
REPLACEMENT INSERT: T5 (BL)

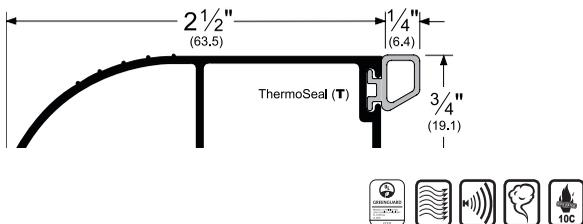

Alternate Insert For 149

149_P

AVAILABLE FINISHES:
A, D
REPLACEMENT INSERT:
P2 (BL, GR)



pile (P)

149_V

AVAILABLE FINISHES:
A, D
REPLACEMENT INSERT:
EV41 (BL, GR, W)



Eco-V™ (V)

2051_T

AVAILABLE FINISHES: A, D
REPLACEMENT INSERT: T5 (BL)

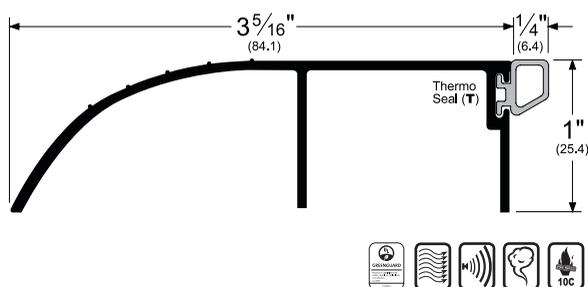

Alternate Insert For 2051

2051_P

AVAILABLE FINISHES:
A, D
REPLACEMENT
INSERT: P2 (BL, GR)



pile (P)

2051_V

AVAILABLE FINISHES:
A, D
REPLACEMENT INSERT:
EV41 (BL, GR, W)



Eco-V™ (V)

SQUAREBACK THRESHOLDS

- Replacement Eco-V™ feet (where applicable) is **EV12GR**
- Interior support leg flushes with interior jamb in application, allowing flooring to squarely abut threshold
- Ideal for tall terra cotta, plush carpet or stone paver entry applications for smooth transition

- Gently sloping and ribbed exterior ramp eliminates trip hazard while providing maximum rain guard. (Be sure to caulk all support legs or lay in mastic for best seal)
- Center support leg provides for engineered threshold stability

2052_

AVAILABLE FINISHES: A, D

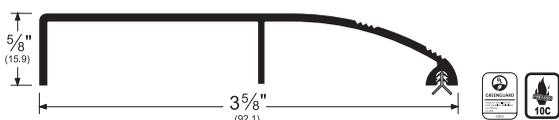

2053_

AVAILABLE FINISHES: A, D

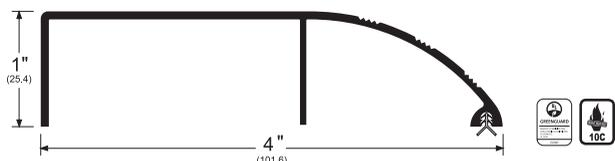

2054_

AVAILABLE FINISHES: A, D

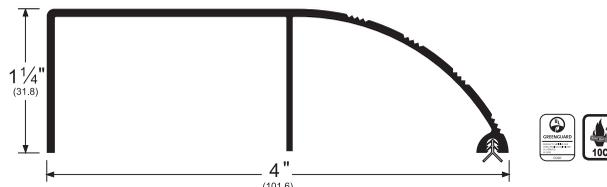

NOTE: Products shown in this section may not be drawn to scale.

AVAILABLE FINISHES FOR PRODUCTS SHOWN ON THIS PAGE
A (Mill Finish Aluminum) D (Dark Bronze Anodized)

800-824-3018 | www.pemko.com

Check the web site for the up-to-date catalog

Copyright © 2015-2024, ASSA ABLOY Accessories and Door Controls Group, Inc., an ASSA ABLOY Group company. All rights reserved.
Reproduction in whole or in part without the express written permission of ASSA ABLOY Accessories and Door Controls Group, Inc. is prohibited.

PEMKO
ASSA ABLOY

Experience a safer
and more open world

OAK THRESHOLDS

- Natural unfinished oak provides beauty as well as thermal benefits
- Available in 36" or 72" lengths only

218OAK

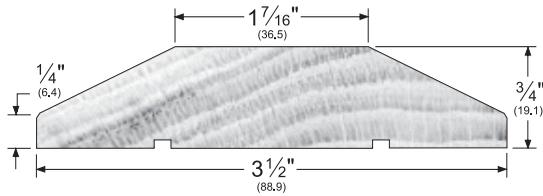

219OAK

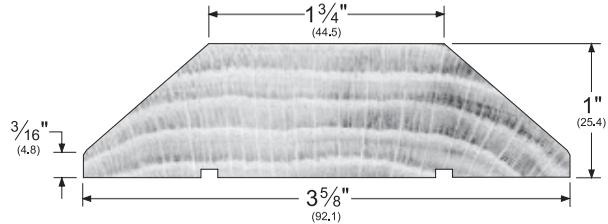

2500W

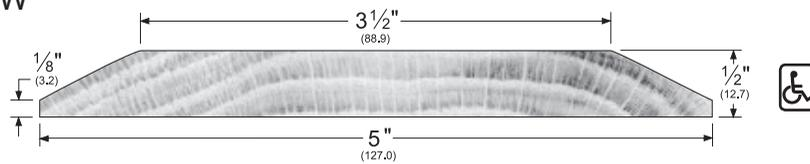

SILL NOSINGS

- Used to cover concrete or wood sill
- Provides an attractive finished look to new and old door openings, covering defects in existing sill
- Sill nosings are held in place with mastic and pressure from threshold placement

324_

AVAILABLE FINISHES: A, B, D



326_

AVAILABLE FINISHES: A, B, D, SN

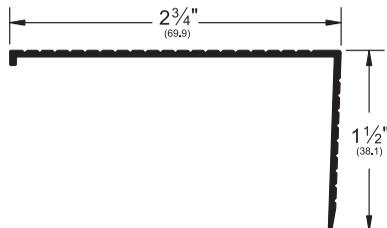

3261_

AVAILABLE FINISHES: A, D, SN

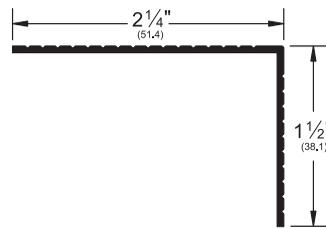

327_

AVAILABLE FINISHES: A, D, PW, SN

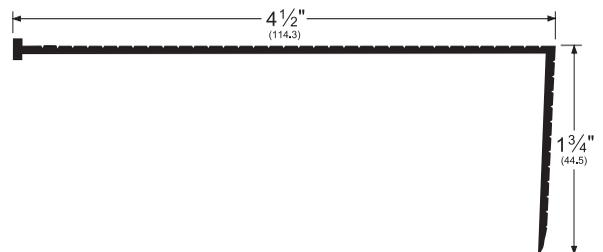

NOTE: Products shown in this section may not be drawn to scale.

AVAILABLE FINISHES FOR PRODUCTS SHOWN ON THIS PAGE

A (Mill Finish Aluminum) B (Mill Finish Extruded Bronze [Brass]) D (Dark Bronze Anodized Aluminum) PW (Painted White Aluminum) SN (Satin Nickel Anodized Aluminum) OAK (Natural Unfinished Oak) W (Solid Oak)

PEMKO
ASSA ABLOY

Experience a safer
and more open world

RESIDENTIAL MILLWORK SILLS

- Silks for use with standard $4\frac{5}{8}$ " jamb width with easy snap-on extension for jambs as wide as $8\frac{3}{4}$ "
- For fabrication options for adjustable or fixed substrate silks, such as honing or sidelite mullion notching, contact Pemko Customer Service
- Residential Silks are designed specifically for the pre-hung door market. They are furnished un-drilled and without screws or nails
- Adjustable up to $\frac{1}{4}$ " to compensate for uneven door bottoms and sub-sill level changes. Two-part zinc plated steel stud shoulder screw joins a long-barreled, zinc plated steel T-nut for superior stability and long-lasting reliability
- PemkoPrene (**PK**) moisture barrier prevents water intrusion. Design of PemkoPrene (**PK**) bulb configuration keeps constant pressure between aluminum cap and aluminum extrusion at any level of adjustment (bulb shown compressed). Replacement insert is **PK74BL**
- Available in standard sizes 32.5", 36.5", and 73.75"

ADJUSTABLE ALUMINUM TOP SILLS

94518_

AVAILABLE FINISHES: A, D

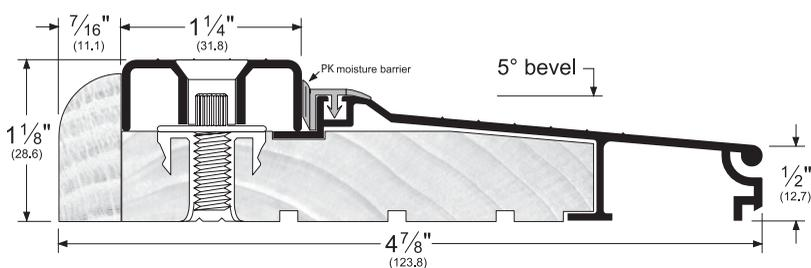

Add "NT" to the end of product number to order narrow trim (i.e. 94518A36.5NT). Full width of sill changes from $4\frac{7}{8}$ " to $4\frac{11}{16}$ ".

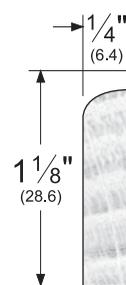

95518_

AVAILABLE FINISHES: A, D

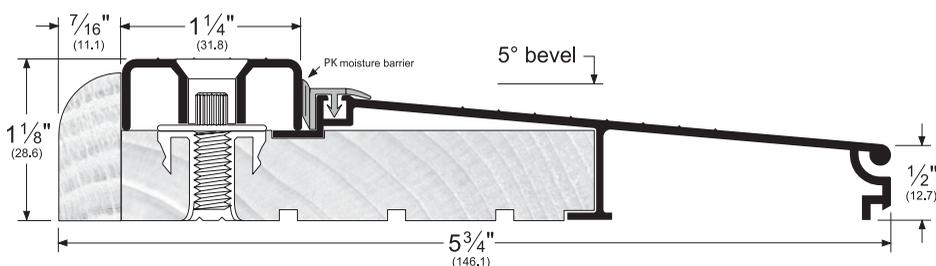

Add "NT" to the end of product number to order narrow trim (i.e. 95518A36.5NT). Full width of sill changes from $5\frac{3}{4}$ " to $5\frac{9}{16}$ ".

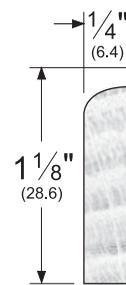

NOTE: Products shown in this section may not be drawn to scale.

AVAILABLE FINISHES FOR PRODUCTS SHOWN ON THIS PAGE

A (Mill Finish Aluminum) D (Dark Bronze Anodized)

800-824-3018 | www.pemko.com

Check the web site for the up-to-date catalog

Copyright © 2015-2024, ASSA ABLOY Accessories and Door Controls Group, Inc., an ASSA ABLOY Group company. All rights reserved. Reproduction in whole or in part without the express written permission of ASSA ABLOY Accessories and Door Controls Group, Inc. is prohibited.

PEMKO
ASSA ABLOY

Experience a safer
and more open world

ADJUSTABLE OAK TOP SILLS

94518_W

AVAILABLE FINISHES: A, D

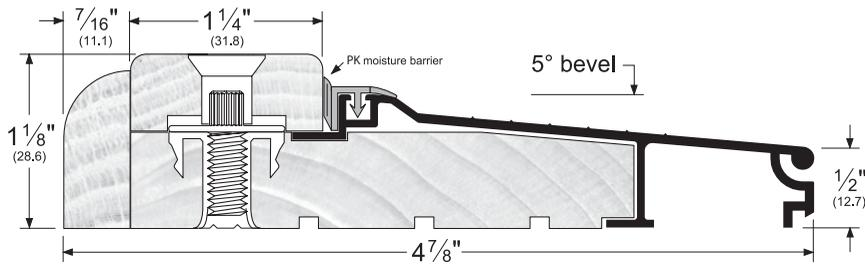

Add "NT" to the end of product number to order narrow trim (i.e. 94518AW36.5NT). Full width of sill changes from 4 7/8" to 4 11/16".

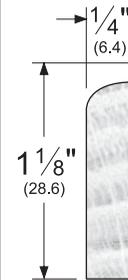

95518_W

AVAILABLE FINISHES: A, D

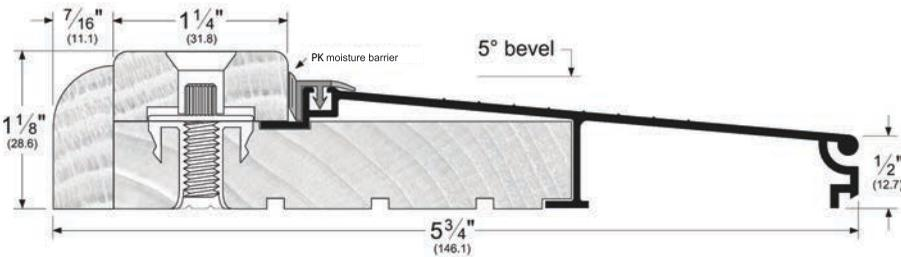

Add "NT" to the end of product number to order narrow trim (i.e. 95518AW36.5NT). Full width of sill changes from 5 3/4" to 5 9/16".

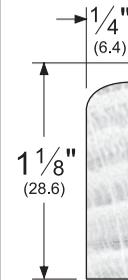

NOTE: Products shown in this section may not be drawn to scale.

AVAILABLE FINISHES FOR PRODUCTS SHOWN ON THIS PAGE
 A (Mill Finish Aluminum) D (Dark Bronze Anodized)



Experience a safer and more open world

OUTSWING ADJUSTABLE OAK TOP SILLS

OS95518_W

AVAILABLE FINISHES: A, D

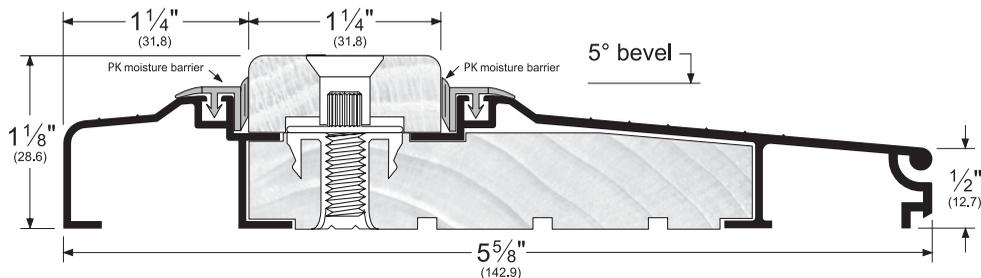

RESIDENTIAL ALL-ALUMINUM ADJUSTABLE SILLS

74518_

AVAILABLE FINISHES: A, D

Available with optional Synthetic Wood Substrate

74518_SYN

AVAILABLE FINISHES: A, D

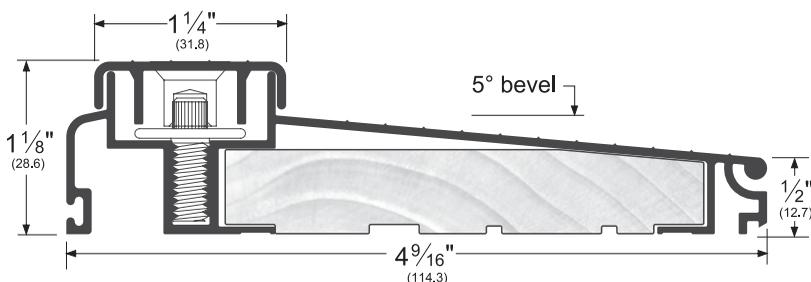

75518_

AVAILABLE FINISHES: A, D

Available with optional Synthetic Wood Substrate

75518_SYN

AVAILABLE FINISHES: A, D

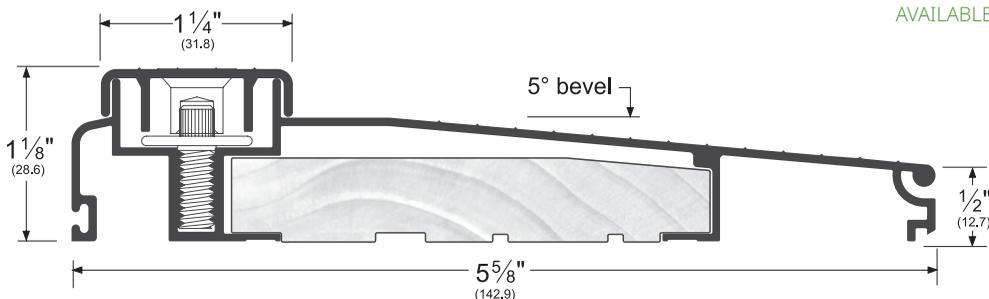

NOTE: Products shown in this section may not be drawn to scale.

AVAILABLE FINISHES FOR PRODUCTS SHOWN ON THIS PAGE
A (Mill Finish Aluminum) D (Dark Bronze Anodized)

800-824-3018 | www.pemko.com

Check the web site for the up-to-date catalog

Copyright © 2015-2024, ASSA ABLOY Accessories and Door Controls Group, Inc., an ASSA ABLOY Group company. All rights reserved.
Reproduction in whole or in part without the express written permission of ASSA ABLOY Accessories and Door Controls Group, Inc. is prohibited.



Experience a safer
and more open world

FIXED ECO-V™ TOP RESIDENTIAL SILLS

- Fixed rigid Eco-V™ (V) cap includes ratchet lock feature which prevents moisture penetration and securely fastens Eco-V™ to aluminum extrusion

N84518_V

AVAILABLE FINISHES: A, D

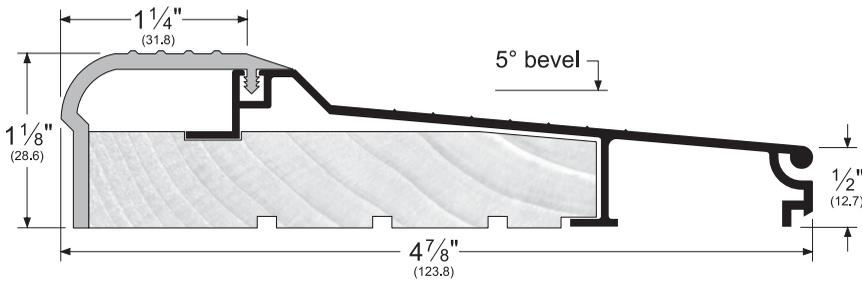

N85518_V

AVAILABLE FINISHES: A, D

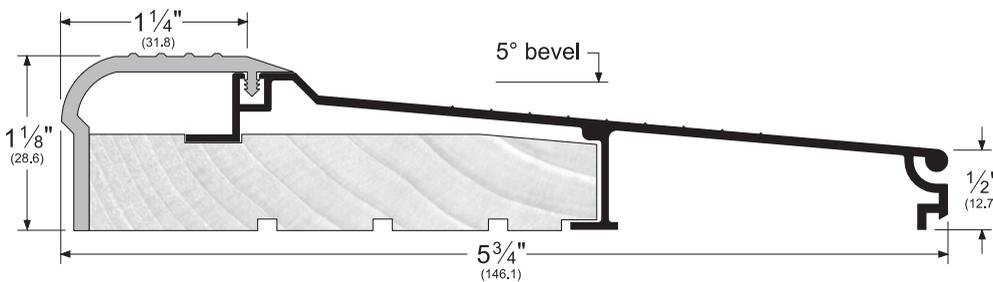

RESIDENTIAL ALL-ALUMINUM FIXED SILLS

84514_

AVAILABLE FINISHES: A, D

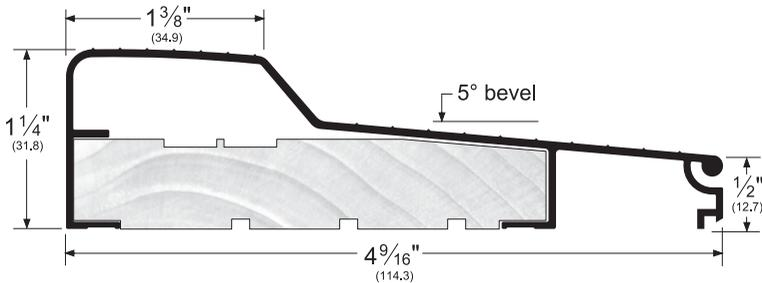

85514_

AVAILABLE FINISHES: A, D

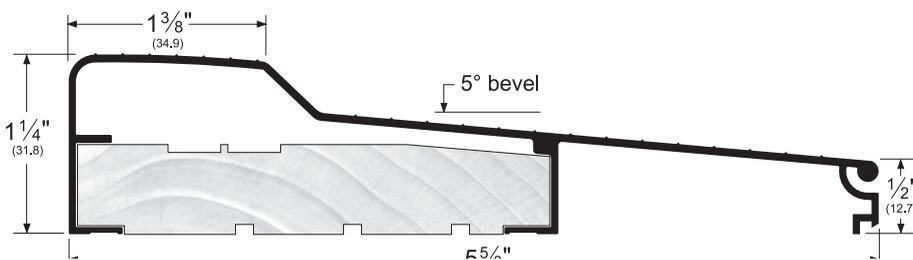

NOTE: Products shown in this section may not be drawn to scale.

AVAILABLE FINISHES FOR PRODUCTS SHOWN ON THIS PAGE
 A (Mill Finish Aluminum) D (Dark Bronze Anodized)



Experience a safer
and more open world

800-824-3018 | www.pemko.com
 Check the web site for the up-to-date catalog

Copyright © 2015-2024, ASSA ABLOY Accessories and Door Controls Group, Inc., an ASSA ABLOY Group company. All rights reserved.
 Reproduction in whole or in part without the express written permission of ASSA ABLOY Accessories and Door Controls Group, Inc. is prohibited.

OUTSWING FIXED BUMPER SILLS

- High dam design restricts water intrusion
- Supplied with high quality Q103 (Q) kerf-in seal
- 8452_Q is extendable to interior

8451_Q

AVAILABLE FINISHES: A, D

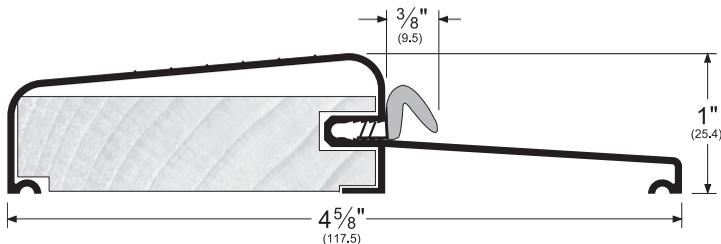

8452_Q

AVAILABLE FINISHES: A, D

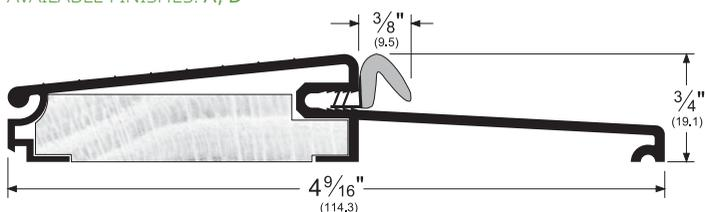

EXTENDERS FOR ALL RESIDENTIAL SILLS

- Extenders fit all 4 7/8" wide and 5 3/4" wide extrusions
- Extenders are available for jambs as wide as 8 3/4"
- Not for use with 8451_Q

EXT3/4_

AVAILABLE FINISHES
A, D

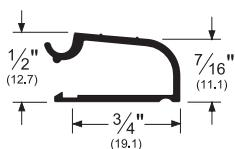

EXT2_

AVAILABLE FINISHES:
A, D

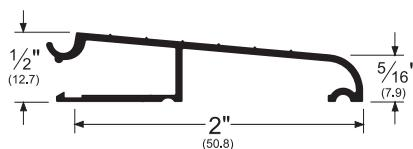

EXT3_

AVAILABLE FINISHES:
A, D

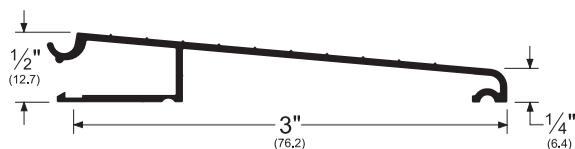

NOTE: Products shown in this section may not be drawn to scale.

AVAILABLE FINISHES FOR PRODUCTS SHOWN ON THIS PAGE

A (Mill Finish Aluminum) D (Dark Bronze Anodized)

For Kerf Gasket: BL (Black) W (White)

800-824-3018 | www.pemko.com

Check the web site for the up-to-date catalog

Copyright © 2015-2024, ASSA ABLOY Accessories and Door Controls Group, Inc., an ASSA ABLOY Group company. All rights reserved.
Reproduction in whole or in part without the express written permission of ASSA ABLOY Accessories and Door Controls Group, Inc. is prohibited.

PENKO
ASSA ABLOY

Experience a safer
and more open world



Experience a safer
and more open world

800-824-3018 | www.pemko.com
Check the web site for the up-to-date catalog

Copyright © 2015-2024, ASSA ABLOY Accessories and Door Controls Group, Inc., an ASSA ABLOY Group company. All rights reserved.
Reproduction in whole or in part without the express written permission of ASSA ABLOY Accessories and Door Controls Group, Inc. is prohibited.



FLOOR MOLDING, TRIM & HANDYSHAPES™

CONTENTS:

Carpet Bar and Seam Binding.....	274
Stair Nosing.....	274
Oak Seam Binding, Floor Edging, and Carpet Trim.....	274

INDEX:

<u>PRODUCT</u>	<u>PAGE</u>	<u>PRODUCT</u>	<u>PAGE</u>
2120	274	2219	274
2132	274	2219W.....	274
2132W.....	274	2500W	274
2134	274		

CARPET BAR - STANDARD

- Carpet Bars protect and provide a neat trim for the edge of carpet

2132_

AVAILABLE FINISHES: **A, G**
AVAILABLE LENGTHS: **36", 72"**

Provided with drive nails

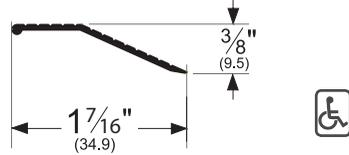

2134_

AVAILABLE FINISHES: **A, G**
AVAILABLE LENGTHS: **36", 72"**

Provided with drive nails

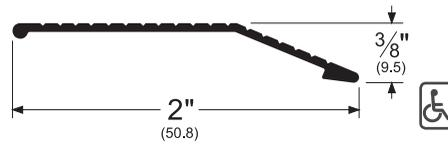

Typical Installation

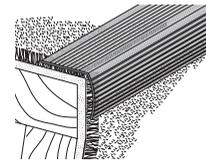

2120_ shown installed

SEAM BINDING

- Covers seams and joins in linoleum, tile, carpet, and other floor coverings

2219_

AVAILABLE FINISHES: **A, G**
AVAILABLE LENGTHS: **36", 72"**

Provided with drive nails

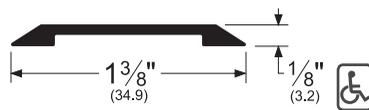

OAK CARPET TRIM

- Covers and protects carpet edges or seams between two surfaces
- Oak is provided unfinished with countersunk holes and brass plated screws

2132W

AVAILABLE FINISH: **W**
AVAILABLE LENGTHS: **36", 72"**

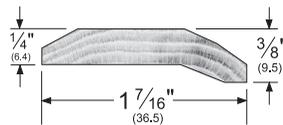

STAIR NOSING

- Protects and improves the appearance of stair edges

2120_

AVAILABLE FINISHES: **A, G**
AVAILABLE LENGTHS: **36", 72"**

Provided with drive nails

Ribbed top surface and fluted face

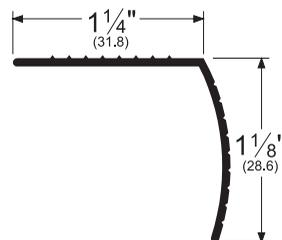

OAK SEAM BINDING

- Oak Seam Binding covers seams between wood, tile, linoleum and other surfaces
- Oak is provided unfinished with countersunk holes and brass plated screws

2219W

AVAILABLE LENGTHS: **36", 72"**

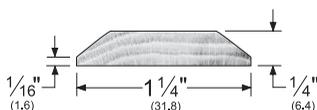

2500W

AVAILABLE LENGTHS: **36", 72"**

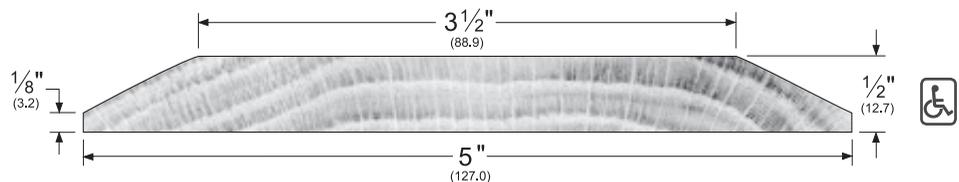

PEMKO
ASSA ABLOY

Experience a safer
and more open world

AVAILABLE FINISHES FOR PRODUCTS SHOWN ON THIS PAGE
A (Mill Finish Aluminum) **G** (Gold Anodized) **W** (Solid Oak)

800-824-3018 | www.pemko.com
Check the web site for the up-to-date catalog

Copyright © 2015-2024, ASSA ABLOY Accessories and Door Controls Group, Inc., an ASSA ABLOY Group company. All rights reserved.
Reproduction in whole or in part without the express written permission of ASSA ABLOY Accessories and Door Controls Group, Inc. is prohibited.

PEMKO WEATHERIZATION PRODUCTS

CONTENTS:

Foam Tape	276
Neoprene Tape	276
Miscellaneous Tape	277
Spring Bronze Weatherstrip	277
Garage Door Weatherstrip	277

INDEX:

PRODUCT	PAGE	PRODUCT	PAGE	PRODUCT	PAGE
P51B17	277	P266	276	P391	276
P240	276	P361V16	277	P392	276
P241	276	P364R16	277	P393	276
P241-30	276	P365V16	277	P394	276
P242	276	P380	277	P396	276
P243	276	P381	277	P397	276
P244	276	P382	277	P398	276
P260	276	P384	277	P480	277
P261	276	P385	276	P484	277
P262	276	P386	276	P490	276
P263	276	P387	277	P491	276
P264	276	P388	277	P493	276
P265	276	P390	276	P497	276

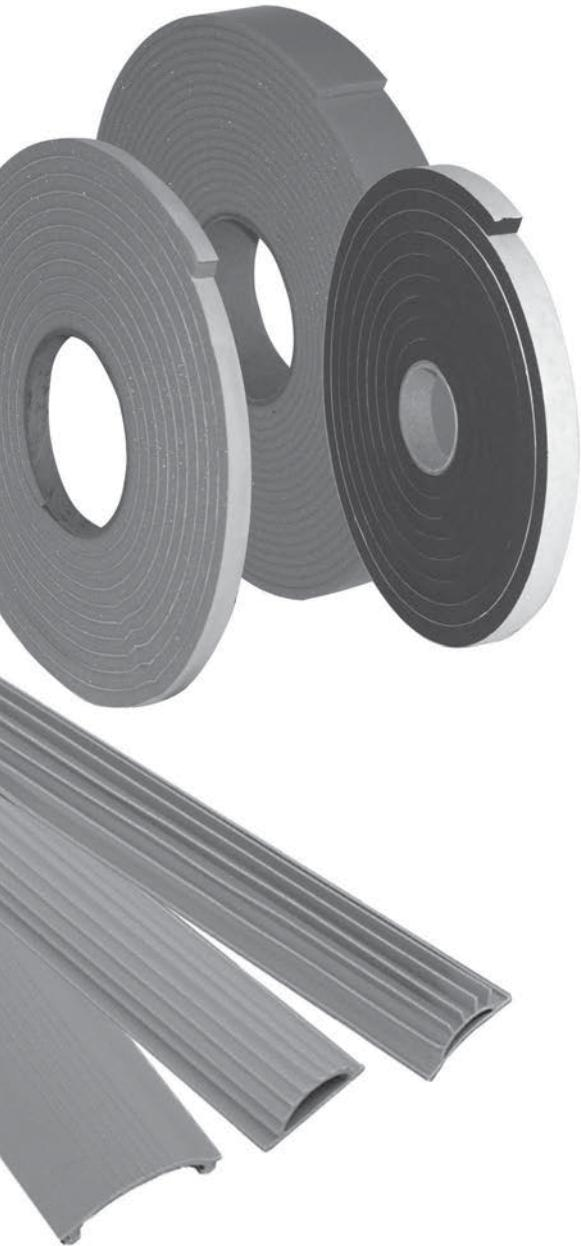

800-824-3018 | www.pemko.com
 Check the web site for the up-to-date catalog

Copyright © 2015-2024, ASSA ABLOY Accessories and Door Controls Group, Inc., an ASSA ABLOY Group company. All rights reserved.
 Reproduction in whole or in part without the express written permission of ASSA ABLOY Accessories and Door Controls Group, Inc. is prohibited.

PEMKO
ASSA ABLOY

Experience a safer
 and more open world

OPEN CELL POLYURETHANE FOAM TAPE

- Easily compressible self-adhesive weatherstrip

Product #	Color	Thickness (T)		Width (W)		Length
P390	Gray	3/16"	x	3/8"	x	17'
P391	White	1/4"	x	3/8"	x	17'
P392	Gray	3/8"	x	3/8"	x	17'
P393	Gray	1/2"	x	1/2"	x	17'
P394	Gray	1/2"	x	3/4"	x	17'
P396	Charcoal	1/4"	x	1/2"	x	17'
P397	White	1/8"	x	3/8"	x	17'
P398	Gray	1/4"	x	3/4"	x	17'

Suggested Installation

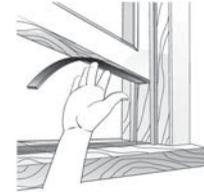

Open Cell Foam Tape installed on casement window.

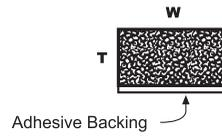

CLOSED CELL SOFT PVC FOAM TAPE

- Flexible, conformable, and softly compressible self-adhesive weatherstrip
- Highly resilient: resists ultraviolet, oxygen and moisture degradation
- Seals against air and water, around doors and windows

Product #	Color	Thickness (T)		Width (W)		Length
P240	Gray	1/8"	x	1/4"	x	17'
P241	Gray	3/16"	x	3/8"	x	17'
P241-30	Gray	3/16"	x	3/8"	x	30'
P242	Gray	1/4"	x	3/8"	x	17'
P243	Gray	3/8"	x	3/8"	x	17'
P244	Gray	3/8"	x	3/4"	x	17'

Suggested Installation

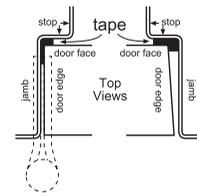

Top view of Closed Cell PVC Soft Foam Tape installed on door opening.

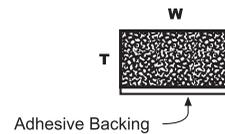

CLOSED CELL FIRM PVC FOAM TAPE

- Moderately compressible self-adhesive weatherstrip

Product #	Color	Thickness (T)		Width (W)		Length
P260	Black	1/8"	x	1/4"	x	17'
P261	Black	3/16"	x	3/8"	x	17'
P262	Black	3/16"	x	3/4"	x	17'
P263	Black	5/16"	x	3/8"	x	10'
P264	Black	5/16"	x	3/4"	x	10'
P265	Black	7/16"	x	3/8"	x	10'
P266	Black	7/16"	x	3/4"	x	10'
P385	Gray	1/4"	x	1/2"	x	10'
P386	Gray	1/4"	x	3/4"	x	10'

Suggested Installation

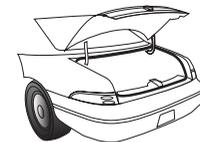

Closed Cell PVC Firm Foam Tape installed as car trunk weatherstrip.

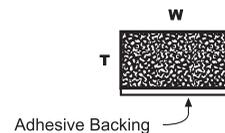

EPDM SPONGE NEOPRENE TAPE

- Slightly compressible self-adhesive weatherstrip
- Resists deterioration and remains flexible at sub-zero temperatures
- Superior product for weatherstripping doors, windows, hatchways, lids and covers

Product #	Color	Thickness (T)		Width (W)		Length
P490	Gray	1/8"	x	3/8"	x	10'
P491	Gray	1/4"	x	3/8"	x	10'
P493	Gray	1/4"	x	1/2"	x	10'
P497	Gray	1/4"	x	3/4"	x	10'

Suggested Installation



EPDM Sponge Neoprene Tape installed as boat hatch weatherstrip

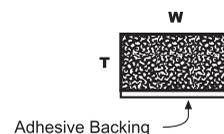

PEMCO
ASSA ABLOY

Experience a safer
and more open world

CLOSED CELL SPONGE NEOPRENE TAPE

- Superior product for weatherstripping homes, cars, trucks and boats
- Resists deterioration from oily substances
- Remains flexible at high and low temperatures

Product #	Color	Thickness (T)		Width (W)		Length
P380	Black	3/16"	x	3/8"	x	10'
P381	Black	5/16"	x	3/8"	x	10'
P382	Black	5/16"	x	3/4"	x	10'
P384	Black	7/16"	x	3/4"	x	10'
P387	Black	3/16"	x	3/4"	x	10'
P388	Black	5/16"	x	1/2"	x	10'
P484	Black	7/16"	x	3/8"	x	10'

Suggested Installation

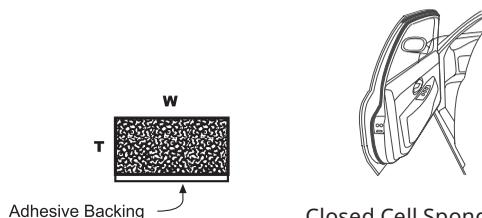

Closed Cell Sponge Neoprene Tape installed as car door weatherstrip.

CLOSED CELL SPONGE VINYL CAMPER TAPE

- Mylar-backed tape cushions between camper and truck

Product #	Color	Thickness (T)		Width (W)		Length
P480	Gray	3/16"	x	1 1/4"	x	30'

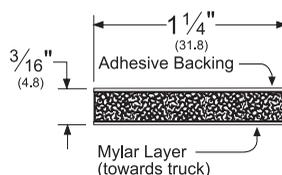

Suggested Installation

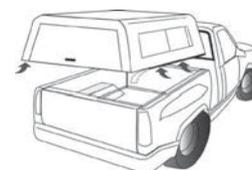

Sponge Vinyl Camper Tape installed as seal between camper and truck bed

SPRING BRONZE WEATHERSTRIP

- For use on wood doors and wood casement windows
- .008" hemmed spring bronze (brass)
- Packaged with nails. Nails should be approximately 1 1/2" on center

Product #	Material	Width		Length
P51B17	Bronze	1 1/8"	x	17'

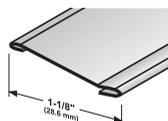

GARAGE DOOR WEATHERSTRIP

- All garage door weatherstrips are furnished with roofing nails

Product #	Color	Height		Width		Length
P361V16	Black	1 1/2"	x	1"	x	16'
P364R16	Black	3/4"	x	2 1/4"	x	16'
P365V16	Gray	1 3/4"	x	5/8"	x	16'

P361V16

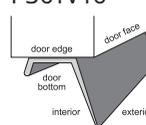

- Nails to door edge, bottom or jamb, closing gaps up to 1 1/2"

P364R16

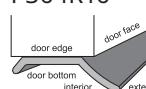

- Nails to door bottom, closing gaps up to 5/8"

P365V16

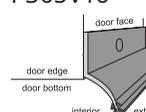

- Nails to door edge, bottom or face, closing gaps up to 1 3/4"



Experience a safer
and more open world

PEMKO FIRE GLAZING TAPE

CONTENTS:

Fire Glazing Tape.....	280
Fire Glazing Tape Applications.....	281

INDEX:

<u>PRODUCT</u>	<u>PAGE</u>	<u>PRODUCT</u>	<u>PAGE</u>
FG3000S45.....	280	FG3000S90.....	280
FG3000S45.....	281	FG3000S90.....	284
FG3000S45.....	282	FG3000S90.....	285
FG3000S45.....	283	HSS2000.....	285
FG3000S45.....	286		



FIRE GLAZING TAPE

- Verify all applications with your door and/or frame manufacturer
- **FG3000S45** and **FG3000S90** are specially formulated high-performance fire glazing tapes
- For exterior fire-rated applications, seal against moisture using standard industry methods

FG3000S45

AVAILABLE LENGTHS: **7', 8', 14', 16'**

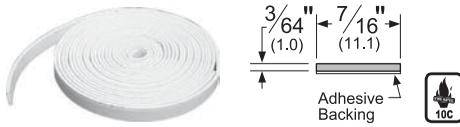

Color: White

FG3000S90

AVAILABLE LENGTHS: **8', 16'**

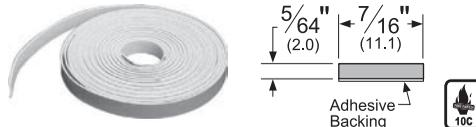

Color: White

Fire Glazing Tape in Larger Lite Applications

Single Vision Lites (Wood/Hollow Metal Door)

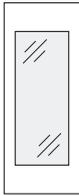

Maximum Height: 84"
 Maximum Width: 34"
 Maximum Total Square Inches (Visible Glass Area): 2,856

- In 20-, 45-, 60- and 90-minute rated wood and hollow metal doors with metal vision frames, the use of FG3000 fire glazing tape allows for much larger vision lites
- In 20- and 45-minute rated hollow metal screens, the use of FG3000 fire glazing tape allows for much larger sidelites, borrowed lites and glass transoms
- New allowable visible glass areas for vision lites in 20- and 45-minute rated wood and hollow metal doors with FG3000S45 is 2,856 square inches with a maximum height of 84" and a maximum width of 34"

Multiple Vision Lites (Hollow Metal Door)

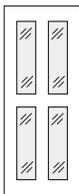

Maximum Height (Each Lite): 12"
 Maximum Width (Each Lite): 46"
 Maximum Combined Square Inches (All Visible Glass Areas): 2,208

- For 90-minute hollow metal doors with **FG3000** fire glazing tape, 12" x 46" vision lites are allowed, but the total number of lites must not exceed four (4) per door. The combined total visible glass area allowed is 2208 square inches



Experience a safer and more open world

800-824-3018 | www.pemko.com
 Check the web site for the up-to-date catalog

Copyright © 2015-2024, ASSA ABLOY Accessories and Door Controls Group, Inc., an ASSA ABLOY Group company. All rights reserved. Reproduction in whole or in part without the express written permission of ASSA ABLOY Accessories and Door Controls Group, Inc. is prohibited.

FG3000S45 FIRE GLAZING TAPE IN 20- AND 45-MINUTE HOLLOW METAL FRAME (SCREEN)

Sidelite/Borrowed Lite/Transom Lite Applications

- Verify all applications with your door and/or frame manufacturer
- For exterior fire-rated applications, a clear silicone caulk is recommended for water proofing

Sectional View of Application

Hollow metal frame for a sidelite, borrowed lite or transom condition.

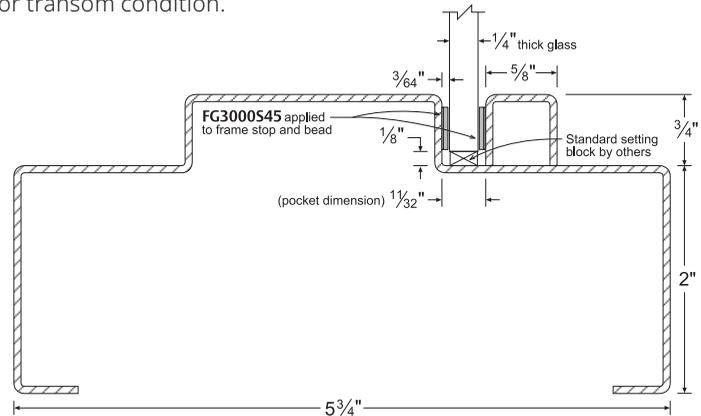

FG3000S45

AVAILABLE LENGTHS: 7', 8', 14', 16'

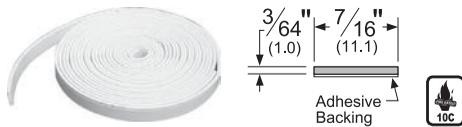

Color: White

Technical Data for 20- And 45-Minute Hollow Metal Screens Equipped with FG3000S45 (Sidelite/Borrowed Lite/Transom Lite Applications)

Lite Configurations

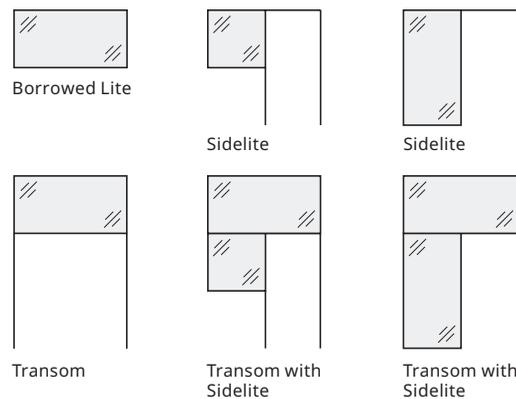
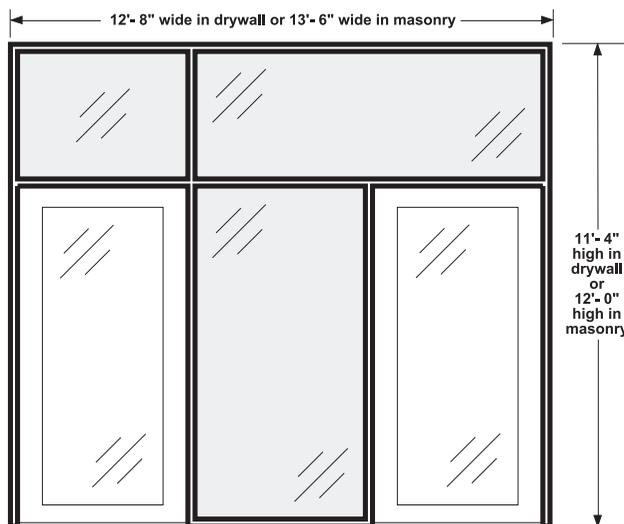

The maximum visible glass area allowed for side lites, borrowed lites, and glass transoms is 4,704 square inches with a maximum length of 106" in any one direction.

Lite Specifications	Hollow Metal Screen Specifications	Listing/Labeling Specifications
<p>Maximum Lite Size: 106" In Any One Direction</p> <p>Maximum Lite Combined Square Inches: Not To Exceed 4,704</p>	<p>Maximum Dimensions (Drywall): 12'8" X 11'4"</p> <p>Maximum Dimensions (Masonry): 13'6" X 12'0"</p> <p>Metal Requirements: Frames are restricted to a minimum of 16-gauge with 5/8" high stops and 18-gauge glazing bead with #8 fasteners at 9" maximum centers</p>	<ul style="list-style-type: none"> • Door and frame must be manufactured by companies that are classified by Underwriters Laboratories Inc.® for the manufacturing and labeling of hollow metal fire doors. Warnock Hersey (I.T.S.) listings are also available through participating hollow metal manufacturers • Listed Glazing Products include: <ul style="list-style-type: none"> - Wire Glazing: Pilkington, Asahi and Central Glass • All vision lite kits must be listed fire door glass frames, packaged with FG3000S45 or FG3000S90 • Individual door and frame manufacturers' modification procedures may vary slightly from the size listings shown



800-824-3018 | www.pemko.com

Check the web site for the up-to-date catalog

Copyright © 2015-2024, ASSA ABLOY Accessories and Door Controls Group, Inc., an ASSA ABLOY Group company. All rights reserved. Reproduction in whole or in part without the express written permission of ASSA ABLOY Accessories and Door Controls Group, Inc. is prohibited.

Experience a safer and more open world

FG3000S45 FIRE GLAZING TAPE IN 20- AND 45-MINUTE HOLLOW METAL DOOR

Metal Vision Frame Applications

- Maximum hollow metal door size: 48" x 120" single, pairs approved
- Door and frame must be manufactured by companies that are classified by Underwriters Laboratories Inc.® for the manufacturing and labeling of hollow metal fire doors and frames. Warnock-Hersey (I.T.S.) listings are also available through participating hollow metal manufacturers
- For exterior fire rated applications, seal against moisture using standard industry methods
- Verify all applications with your door and/or frame manufacturer

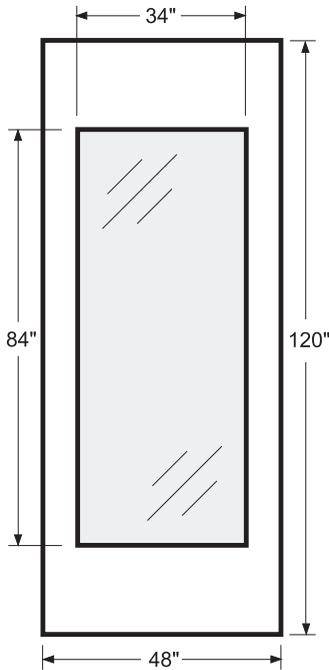

For 20 minute and 45 minute the maximum visible glass size allowed is 34" wide x 84" high or 2,856 square inches per vision lite.

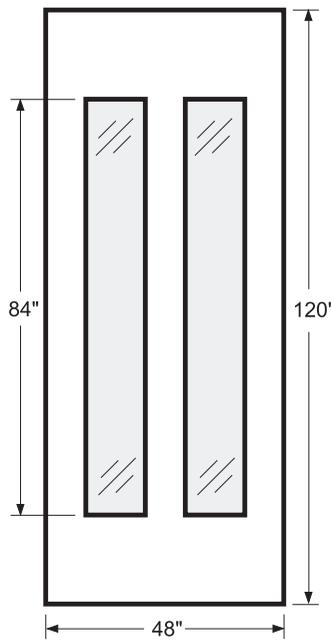

Multiple vision lites are allowed in both the 20 minute and 45 minute, but the combined total visible glass area allowed is 2,856 square inches per door.

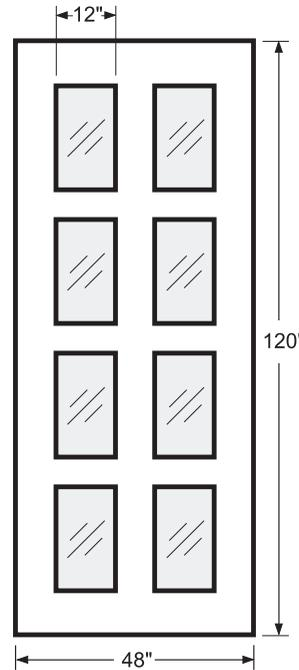

FG3000S45

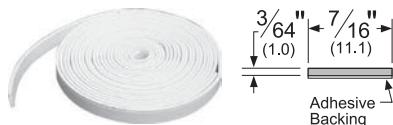

Color: White

Sectional View of Applications

FG3000S45 applied between frame and glass

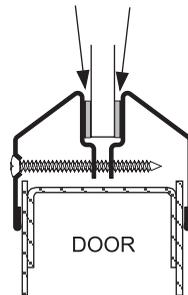

Beveled



FG3000S45 applied between frame and glass

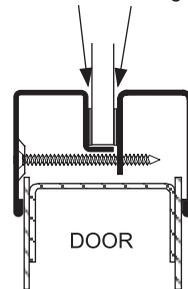

Square



PEMKO
ASSA ABLOY

Experience a safer and more open world

FG3000S45 FIRE GLAZING TAPE IN 20- AND 45-MINUTE WOOD DOOR

Metal Vision Frame Applications

FG3000S45

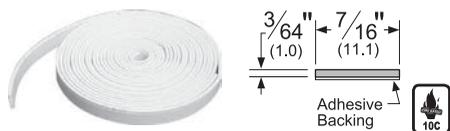

Color: White

Sectional View of Applications

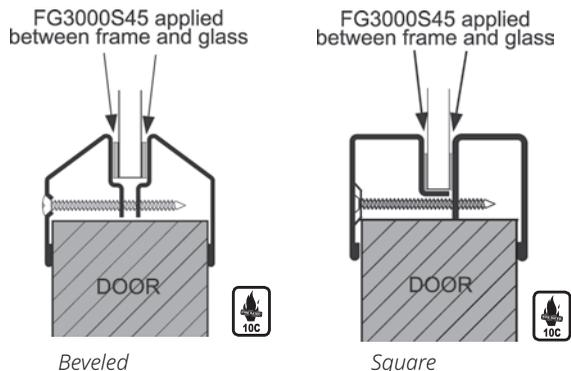

Technical Data for 20- And 45-Minute Wood Doors Equipped with FG3000S45 (Metal Vision Frame, Single and Multiple Lite Applications)

Lite Configurations

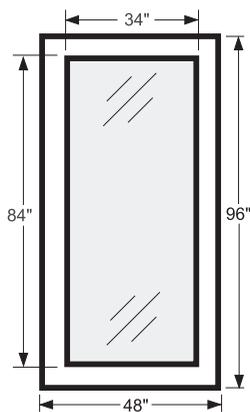

Single Vision Lite

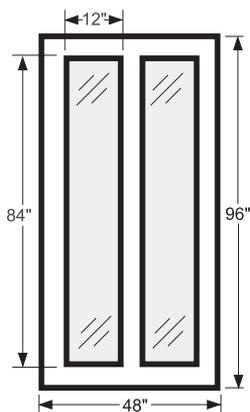

Multiple Vision Lites

The maximum visible glass area allowed for single lites is 34" wide x 84" high; for single and multiple lites, the total visible glass area allowed is 2,856 square inches per door.

Lite Specifications	Door Specification	Listing/Labeling Specifications
<p>Maximum Dimensions (Single Lite): 34" wide x 84" high, 2,856 square inches per lite</p> <p>Maximum Combined Dimensions (Multiple Lites): Multiple vision lites are allowed in both the 20- and 45-minute doors, but the combined total visible glass area allowed is 2,856 square inches per door.</p>	<p>Maximum Dimensions: Or both 20- and 45-minute doors, the maximum wood door size is 48" x 96" single, pairs approved</p>	<ul style="list-style-type: none"> • Door and frame must be manufactured by companies that are classified by Underwriters Laboratories Inc.® for the manufacturing and labeling of hollow metal fire doors. Warnock Hersey (I.T.S.) listings are also available through participating hollow metal manufacturers • Listed Glazing Products include: <ul style="list-style-type: none"> - Wire Glazing: Pilkington, Asahi and Central Glass • Individual door and frame manufacturers' modification procedures may vary slightly from the size listings shown

FG3000S90 FIRE GLAZING TAPE IN 90-MINUTE HOLLOW METAL DOOR METAL VISION FRAME APPLICATIONS

- Verify all applications with your door and/or frame manufacturer
- For exterior fire-rated applications, seal against moisture using industry standard methods

FG3000S90

AVAILABLE LENGTHS: 8', 16'

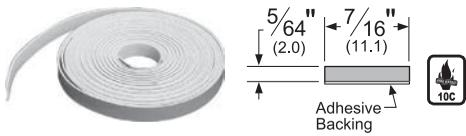

Color: White

Sectional View of Applications

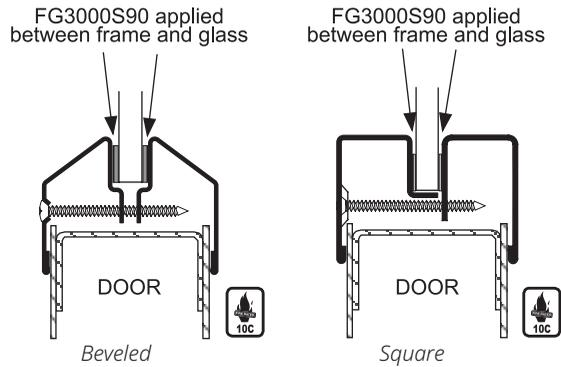

Technical Data for 90-Minute Hollow Metal Doors Equipped with FG3000S90 (Metal Vision Frame, Single And Multiple Lite Applications)

Lite Configurations

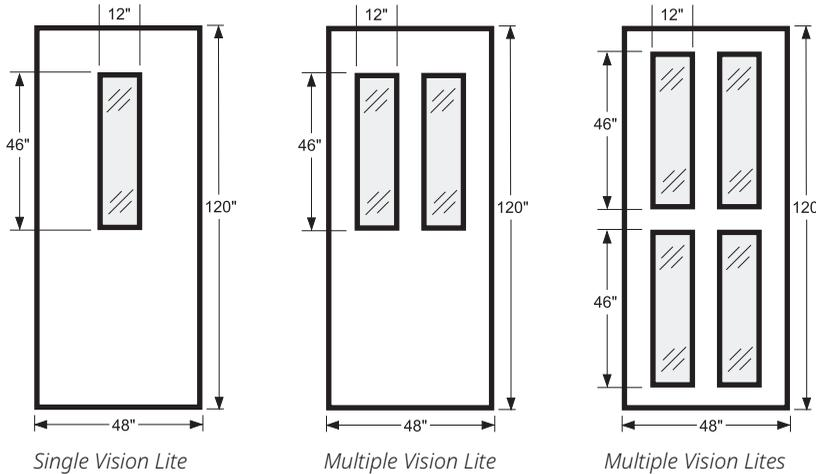

The maximum visible glass area allowed for single lites is 12" wide x 46" high or 552 square inches per vision lite; for multiple lites, the largest approved door configuration is two (2) vision lites at 12" wide x 46" high above two (2) vision lites at 12" wide x 46" high (as shown at far right). No more than four (4) lites are allowed per door, and the combined total visible glass area allowed is 2,208 square inches per door.

Lite Specifications	Door Specification	Listing/Labeling Specifications
<p>Maximum Dimensions (Single Lite): 12" wide x 46" high, 552 square inches per lite</p> <p>Maximum Combined Dimensions (Multiple Lites): Multiple vision lites are allowed in 90-minute doors, but the combined total visible glass area allowed is 2,208 square inches per door. No more than four (4) lites are allowed per door. The largest approved configuration is above two (2) vision lites at 12" wide x 46" high above two vision lites at 12" wide x 46" high.</p>	<p>Maximum Dimensions: For 90-minute doors, the maximum hollow metal door size is 48" x 120" single, pairs approved.</p>	<ul style="list-style-type: none"> • Door and frame must be manufactured by companies that are classified by Underwriters Laboratories Inc.® for the manufacturing and labeling of hollow metal fire doors. Warnock Hersey (I.T.S.) listings are also available through participating hollow metal manufacturers • Listed Glazing Products include: <ul style="list-style-type: none"> - Wire Glazing: Pilkington, Asahi and Central Glass • Individual door and frame manufacturers' modification procedures may vary slightly from the size listings shown.



Experience a safer and more open world

FG3000S90 FIRE GLAZING TAPE IN 60- AND 90-MINUTE WOOD DOORS

Metal Vision Frame Applications

- Verify all applications with your door and/or frame manufacturer
- For exterior fire-rated applications, a clear silicone caulk is recommended for water proofing

FG3000S90

AVAILABLE LENGTHS: 8', 16'

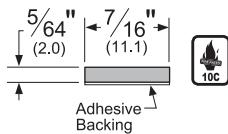

HSS2000

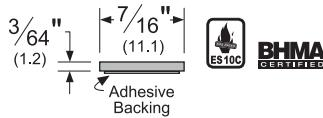

HSS2000 is required to be installed with FG3000S90 for positive pressure applications only. For more information about HSS2000, please see the Adhesive Gasketing section.

Sectional View of Applications

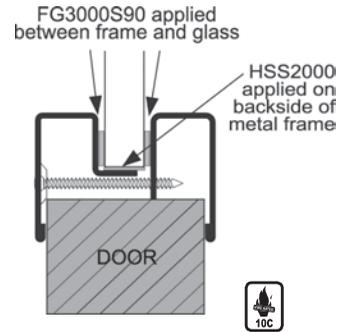

Technical Data for 60- and 90-Minute Wood Doors Equipped with FG3000S90 & HSS2000 (Metal Vision Frame, Single and Multiple Lite Applications)

Lite Configurations

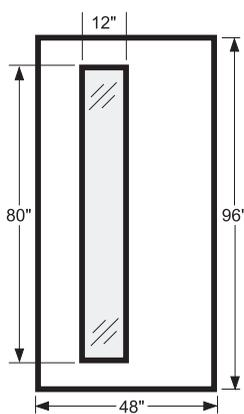

Single Vision Lite, 60-Minute Door

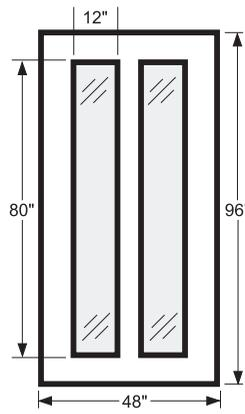

Multiple Vision Lites, 60-Minute Door

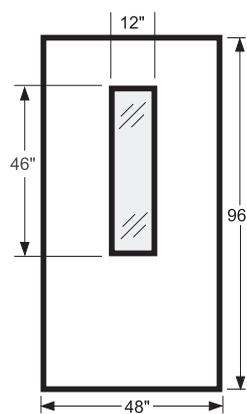

Single Vision Lite, 90-Minute Door

The maximum visible glass area allowed for 60-minute single lites is 12" wide x 80" high or 960 square inches per vision lite; 90-minute doors are allowed a maximum visible glass area of 12" wide x 46" high or 552 square inches per vision lite. Multiple lites (allowed on 60-minute doors only) have a maximum combined visible glass area of 1,920 square inches per door.

Lite Specifications	Door Specification	Listing/Labeling Specifications
<p>Maximum Dimensions (Single Lite, 60-Minute): 12" wide x 80" high; 960 square inches per lite</p> <p>Maximum Dimensions (Single Lite, 90-Minute): 12" wide x 46" high; 552 square inches per lite</p> <p>Maximum Combined Dimensions (Multiple Lites, 60-Minute): Multiple vision lites are allowed in 60-minute doors only; the combined total visible glass area allowed is 1,920 square inches per door</p>	<p>Maximum Dimensions: For both 60- and 90-minute doors, the maximum wood door size is 48" x 96" single, pairs approved</p>	<ul style="list-style-type: none"> • Door must be manufactured by companies that are classified by Underwriters Laboratories Inc.® for the manufacturing and labeling of hollow metal fire doors. Warnock Hersey (I.T.S.) listings are also available through participating hollow metal manufacturers. • Listed Glazing Products include: <ul style="list-style-type: none"> – Wire Glazing: Pilkington, Asahi and Central Glass • Individual door and frame manufacturers' modification procedures may vary slightly from the size listings shown • HSS2000 is required on Positive Pressure applications only

FG3000S45 FIRE GLAZING TAPE IN 20- AND 45-MINUTE WOOD DOORS AND FRAMES

FG3000S45

AVAILABLE LENGTHS:
7', 8', 14', 16'

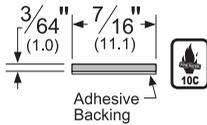

- Verify all applications with your door and/or frame manufacturer
- For exterior fire-rated applications, seal against moisture using standard industry methods
- Wood vision frames rated 20-minute and 45-minute
- Wood sidelite frames rated 20-minute and 45-minute
- Wood borrowed lite frames rated 20-minute and 45-minute

Technical Data for 20-Minute Wood Sidelite Frame/Wood Lite Bead/Clear Tempered Glass

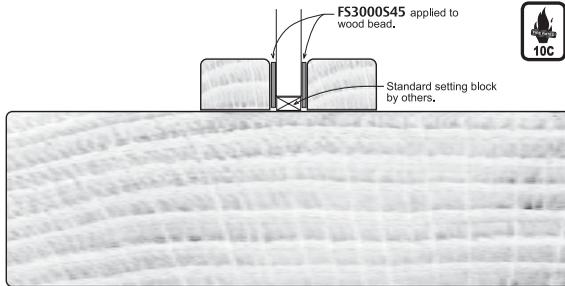

Maximum Visible Glazing Dimensions (Sidelite):

32⁷/₈" x 87¹³/₁₆"

Glazing Materials (Sidelite):

- PyroEdge 20™ by Interedge Technologies
- Fireglass 20™ by Technical Glass Products

Listing/Labeling Specifications:

- Positive Pressure Tested and Listed
- Verify availability with door and frame manufacturer

Technical Data For 20-Minute Full Lite Wood Door/Wood Lite Frame/Clear Tempered Glass

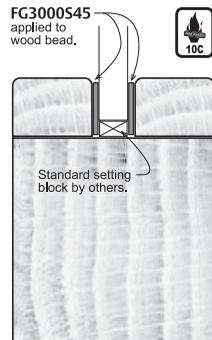

Maximum Visible Glazing Dimensions (Lite):

- (4'0" x 8'0" Door): 32⁷/₈" x 75¹³/₁₆"
- (4'0" x 8'0" Door): 32⁷/₈" x 75¹³/₁₆"

Glazing Materials (Sidelite):

- PyroEdge 20™ by Interedge Technologies
- Fireglass 20™ by Technical Glass Products

Listing/Labeling Specifications:

- Positive Pressure Tested and Listed
- Verify availability with door and frame manufacturer

Technical Data for: 20- and 45-Minute Full Lite Wood Door/Wood Lite Frame With Wire Glass or FireLite™, 20- and 45-Minute Wood Sidelite Frame/Borrowed Lite Frame/Transom Lite Frame with Wire Glass or FireLite™

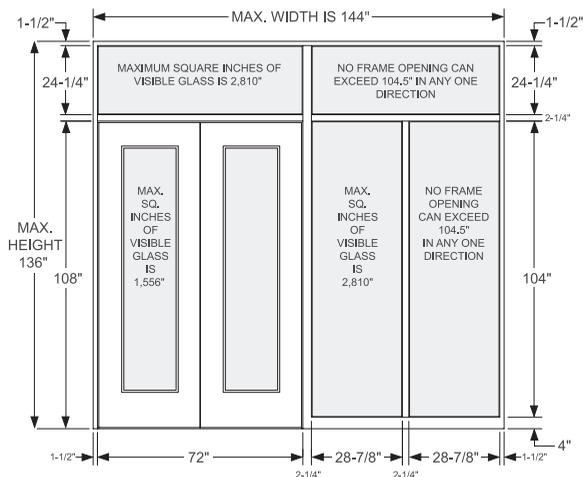

Lite Specifications (see diagram at left):

- Positive Pressure Tested and Listed
- Large visible glazing areas
- Wire Glass and FireLite™
- Verify availability with door and frame manufacturer.

Contact These Manufacturers:

Navy Island, Inc.

275 Marie Ave East, West St. Paul, MN 55118
Phone: 651.451.4454, Fax: 651.451.4484

Eggers Industries - Frame Plant

1819 East River Street, Two Rivers, WI 54241
Phone: 920.793.1351, Fax: 920.793.2958



Experience a safer
and more open world

800-824-3018 | www.pemko.com
Check the web site for the up-to-date catalog

Copyright © 2015-2024, ASSA ABLOY Accessories and Door Controls Group, Inc., an ASSA ABLOY Group company. All rights reserved. Reproduction in whole or in part without the express written permission of ASSA ABLOY Accessories and Door Controls Group, Inc. is prohibited.

PEMKO DOOR & FRAME ACCESSORIES



CONTENTS:

Glazing Bead/Spreader Bar	288
Reinforcements - Fillers	288
Reinforcements - Misc.	289

INDEX:

<u>PRODUCT</u>	<u>PAGE</u>
CB1-50PK.....	288
CR2-5PK.....	289
GS2-20PK.....	288
GS3-20PK.....	288
GS4-20PK.....	288
HF3-25PK.....	288

800-824-3018 | www.pemko.com
Check the web site for the up-to-date catalog

Copyright © 2015-2024, ASSA ABLOY Accessories and Door Controls Group, Inc., an ASSA ABLOY Group company. All rights reserved.
Reproduction in whole or in part without the express written permission of ASSA ABLOY Accessories and Door Controls Group, Inc. is prohibited.

PEMKO
ASSA ABLOY

Experience a safer
and more open world

GLAZING BEAD/SPREADER BAR

Glazing Bead

- Sold in 20 packs only
- No fasteners supplied

- GS2-20PK**
- $\frac{5}{8}$ " H x $\frac{3}{4}$ " W x 10'0" L (Outer Dimension)
 - Punched and countersunk for #8 screw
 - Hole spacings are 6" from ends and 12" on center
 - .049 18 gauge A40 galvanized steel
- GS3-20PK**
- $\frac{5}{8}$ " H x $\frac{3}{4}$ " W x 10'0" L (Outer Dimension)
 - Blank (no holes)
 - .049 18 gauge A40 galvanized steel
- GS4-20PK**
- $\frac{5}{8}$ " H x $\frac{3}{4}$ " W x 3'0" L (Outer Dimension)
 - Blank (no holes)
 - .049 18 gauge A40 galvanized steel

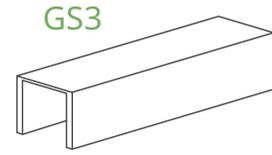

REINFORCEMENTS - FILLERS

Corner Fillers

- Holes in one side for anchoring $1\frac{5}{8}$ " x $1\frac{5}{8}$ "
- .065 - 16 gauge galvanized steel
- Sold in 50 packs only

- CB1-50PK**
- 2" face frame corner filler.
 - $\frac{5}{8}$ " x $\frac{7}{16}$ " lip x $1\frac{13}{16}$ " wide

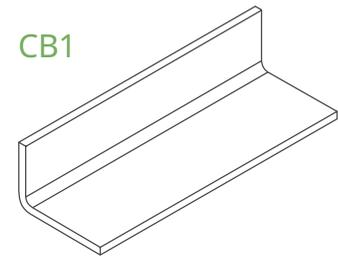

Frame Hinge Filler Plate

- For $1\frac{3}{4}$ " rabbeted frames
- Two (2) #12-24 x $\frac{1}{2}$ " F.H.M.S.
- Sold in 25 packs only

- HF3-25PK**
- $4\frac{1}{2}$ " hinge filler for frames.
 - $1\frac{5}{8}$ " x $4\frac{1}{2}$ " x .134 HRPO

HF3

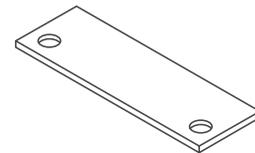

REINFORCEMENTS - MISC.

Weld-In Reinforcements

- Weld-in closer reinforcement
- CR2 sold in 5 packs only
- CR3 sold in 20 packs only

CR2-5PK

- 12" flat closer reinforcement for standard and PA mount closers
- 1³/₄" x 12" x .134 - 10 gauge HRPO

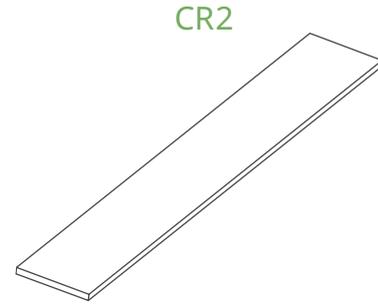

NOTES



Experience a safer
and more open world

800-824-3018 | www.pemko.com
Check the web site for the up-to-date catalog

Copyright © 2015-2024, ASSA ABLOY Accessories and Door Controls Group, Inc., an ASSA ABLOY Group company. All rights reserved.
Reproduction in whole or in part without the express written permission of ASSA ABLOY Accessories and Door Controls Group, Inc. is prohibited.

NOTES

800-824-3018 | www.pemko.com

Check the web site for the up-to-date catalog

Copyright © 2015-2024, ASSA ABLOY Accessories and Door Controls Group, Inc., an ASSA ABLOY Group company. All rights reserved.
Reproduction in whole or in part without the express written permission of ASSA ABLOY Accessories and Door Controls Group, Inc. is prohibited.



Experience a safer
and more open world

The ASSA ABLOY Group is the global leader in access solutions.
Every day, we help billions of people experience a more open world.

ASSA ABLOY Opening Solutions leads the development within door openings and products for access solutions in homes, businesses and institutions. Our offering includes doors, frames, door and window hardware, mechanical and smart locks, access control and service.

PEMKO
ASSA ABLOY

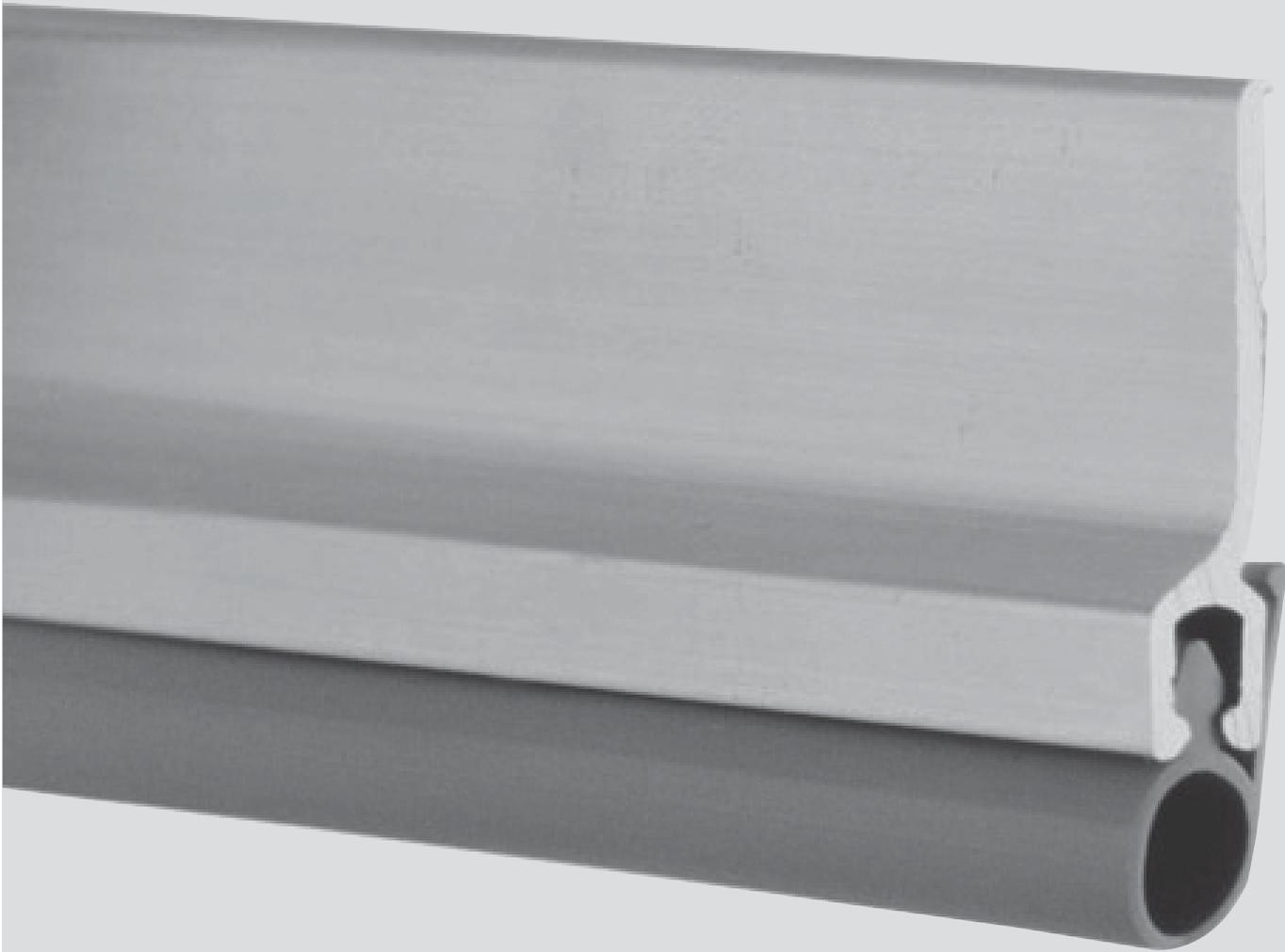

Pemko
5535 Distribution Dr.
Memphis, TN 38141
www.pemko.com
orders.pemko@assaabloy.com

Memphis, TN USA
P: 800 824 3018
F: 800 243 3656

Ventura, CA USA
P: 800 283 9988
F: 800 283 4050

Vaughan, ON CA
P: 800 461 3007
F: 800 461 8989